

# Minerallac<sup>®</sup> Company



**Cully**<sup>™</sup>



**Minerallac**<sup>®</sup>  
*Traditional*



**Black Claw**<sup>™</sup>



**IMPACT**<sup>®</sup>  
STAPLES



**REDMORE**<sup>®</sup>

CONTRACTOR CATALOG

## Contact Us

### Phone

#### Corporate Office

800-927-3293

8:00 A.M. to 5:00 P.M. CT

#### Regional Office

800-927-3293

8:00 A.M. to 5:00 P.M. PT

### Mail

#### Corporate Office

100 Gast Road

Hampshire, IL

#### Regional Office

4200 9th Avenue NW

Seattle, WA 98107

### Fax

#### Corporate Office

800-824-8942

#### Regional Office

206-789-9362

### Online/Email

#### Web

[www.minerallac.com](http://www.minerallac.com)

#### Customer Service

[CustomerService@minerallac.com](mailto:CustomerService@minerallac.com)

## OUR MISSION

Minerallac Company is dedicated to delivering time-sensitive and flexible service that maximizes the value of its trusted brands.

Through our distribution network and commitment to Minerallac Company professionals, we live out this mission. This allows your customers to receive the highest quality of products, performance and service.



## WHY MINERALLAC?

Consolidation of our brands under one corporate umbrella provides a comprehensive package of hangers, fasteners, anchors and safety products. It also reinforces our mission to deliver time-sensitive and flexible service that maximizes the value of our trusted brands.

### The Minerallac Company brands offer:

**Minerallac Traditional®** offers hangers, straps and beam clamps in more sizes and finishes than any other single source.

**Cully™** offers one of the broadest lines of fasteners, anchors, tools and safety products for the industry.

**Black Claw™** offers an expansive line of spring steel fasteners.

**IMPACT Staples®** offers residential and commercial staples.

**Redmore®** offers staples, nails as well as wire products for the utility market.

This comprehensive assembly of products began in 1894 and continues today. Over the years, the relationship we have built together has given us an understanding of your business. This understanding has allowed us to address your specific needs in an effective and tangible way through relevant, meaningful solutions at cost-effective prices.

We thank you for the opportunity to work together. We hope you will find this new catalog a valuable resource that is helpful and easy to use.



Quality Since 1894



### Cully Pictorial Index

Pages 1–12

### Screws

Pages 14–54

### Grounding

Pages 55–56

### Nuts/Washers

Pages 57–68

### Bolts

Pages 69–75

### Anchors

Pages 76–100

### Hangers

Pages 101–110

### Paints & Chemicals

Pages 111–129

### Tools

Pages 130–174

### Safety

Pages 175–185

### Miscellaneous

Pages 186–192

### Minerallac Pictorial Index

Pages 193–200

### Minerallac Traditional

Pages 201–232

### Black Claw

Pages 233–258

### Dimension Charts

Pages 259–260

### Impact Staples

Pages 261–266

### Redmore

Pages 267–278

### Displays

Pages 279–283

### Numerical Index

Pages 284–295

### Alphabetical Index

Pages 296–302

The following trademarks are the property of Minerallac Company.



**Minerallac**<sup>®</sup>  
Company



**Minerallac**  
*Advantage*<sup>™</sup>

**Cully**<sup>™</sup>

**Minerallac**<sup>®</sup>  
*Traditional*

**Black Claw**<sup>™</sup>

**IMPACT**<sup>®</sup>  
STAPLES

**RENMORE**<sup>®</sup>

Drive Stop, Min-E, Jiffy Clip, and graphic  icon design on the Impact Staples logo are also registered trademarks of Minerallac Company.

Minerallac Company holds patents on the following; Barbed Staples Pat. No. #D484,032, Saddle Retrofit for Bridal Rings Pat. No. #6,325,338.

All other trademarks identified in this catalog are the property of the particular supplier or vendor of that product. Minerallac Company has made every attempt to correctly identify these trademarks and at no time assumes to represent these as trademarks of their own.



***Cully***™

PICTORIAL INDEX

### SHEET METAL SCREWS

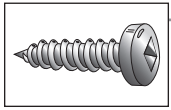

**Pan Head, Sheet Metal Screw, Square**  
pages 14–16

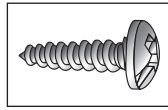

**Pan Head, Sheet Metal Screw, Phillips/Slotted**  
page 17

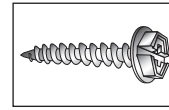

**Hex Washer Head, Sheet Metal Screw, Phillips/Slotted**  
page 18

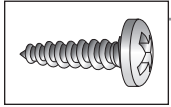

**Pan Head, Sheet Metal Screw, Phillips**  
page 18

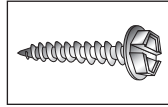

**Hex Washer Head, Sheet Metal Screw, Slotted**  
page 19

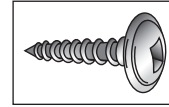

**Round Washer Head, Sheet Metal Screw, Square**  
page 20

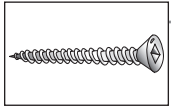

**Flat Head, Sheet Metal Screw, Square**  
pages 21–22

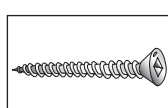

**Oval Head, Sheet Metal Screw, Square**  
page 22

### METAL PIERCING STUD SCREWS

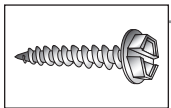

**Hex Washer Head, Stud Screw, Slotted Sharp Point**  
page 23

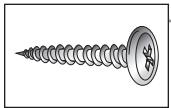

**Wafer Head, Stud Screw, Phillips Sharp Point**  
page 23

### FRAMING SCREWS

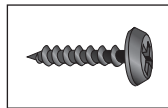

**Pan Head Framing, Phillips**  
page 24

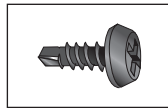

**Pan Head Framing, Phillips Tek**  
page 24

### TAPCON™ CONCRETE SCREWS

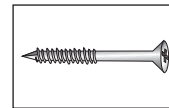

**Flat Head, Concrete Screw, Phillips**  
page 87

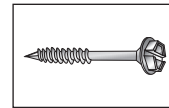

**Hex Washer Head, Concrete Screw, Slotted**  
page 88

### PLATE SCREWS

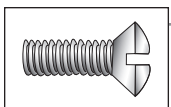

**Wall Plate Oval Head, Slotted**  
page 38

### CAP SCREWS

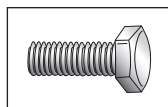

**Hex Head Cap**  
pages 50–51

### BRASS SCREWS

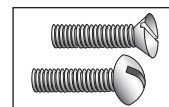

**Brass Machine Screws, Round & Flat Head**  
page 52

### TEK SCREWS

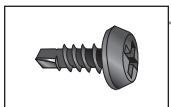

**Pan Head Framing, Phillips Tek**  
page 24

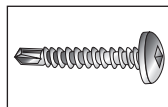

**Pan Head, Square Tek**  
page 25

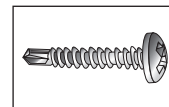

**Pan Head, Phillips Tek**  
page 26

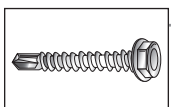

**Hex Washer Head, Tek**  
pages 27–28

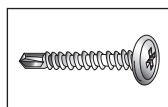

**Wafer Head Lath, Phillips Tek**  
page 28

### WOOD, PARTICLE BOARD, DRYWALL & DECK SCREWS

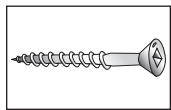

**Flat Head, Wood Screws, Square**  
pages 39–40

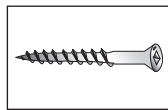

**Trim Head, Wood Screws, Square**  
page 41

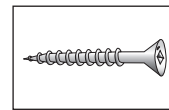

**Deep Thread Particle Board, Square**  
pages 41–42

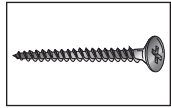

**Fine Thread Drywall, Phillips**  
page 43

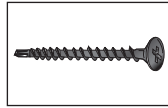

**Fine Thread Drywall, Phillips Tek**  
page 43

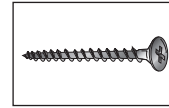

**Coarse Thread Drywall, Phillips**  
page 44

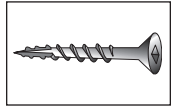

**Woodex® All Weather Deck Screws, Square**  
page 45

### TAMPERPROOF

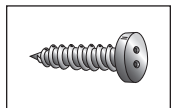

**Spanner Head, Pan, Flat & Oval Head Sheet Metal Screw**  
page 46

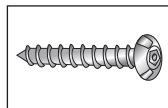

**Socket Pin, Button Head Sheet Metal Screw**  
page 47

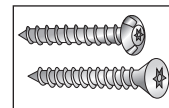

**Star Pin, Button & Flat Head Sheet Metal Screw**  
page 47

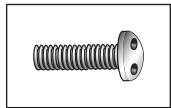

**Spanner Head, Pan, Flat & Oval Head Machine Screw**  
page 48

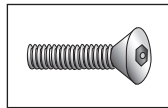

**Socket Pin, Button & Flat Head Machine Screw**  
page 49

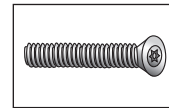

**Star Pin, Button & Flat Head Machine Screw**  
page 49



**Tamperproof Screwdriver**  
page 135



**Tamperproof Kit**  
page 139



**Tamperproof Bits**  
page 143

### MACHINE SCREWS

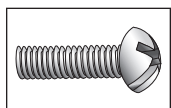

**Round Head, Machine Screw, Phillips/Slotted**  
pages 29–30

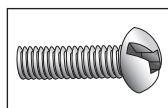

**Round Head, Machine Screw, Square/Slotted**  
pages 31–32

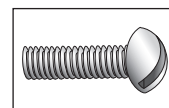

**Round Head, Machine Screw, Slotted**  
page 33

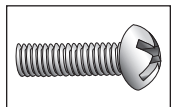

**Round Head, Machine Screw, Phillips**  
page 33

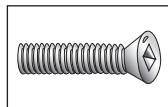

**Flat Head, Machine Screw, Square**  
page 34

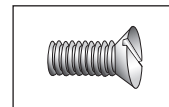

**Flat Head, Machine Screw, Slotted**  
pages 35–36

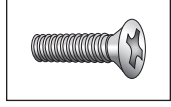

**Flat Head, Machine Screw, Phillips**  
page 36

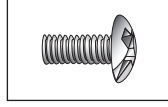

**Truss Head, Machine Screw, Phillips/Slotted**  
page 37

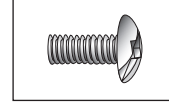

**Truss Head, Machine Screws, Square/Slotted**  
page 37

### SCREW HOOKS & EYES

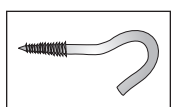

**Screw Hooks**  
page 53

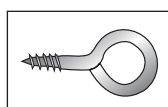

**Screw Eyes**  
page 53

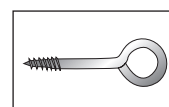

**Screw Eye Lags**  
page 54

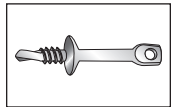

**Acoustical Eye Tek**  
page 54

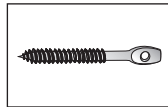

**Acoustical Eye Lags**  
page 54

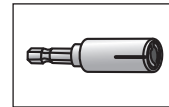

**Acoustical Eye Driver**  
page 54

### GROUNDING SCREWS

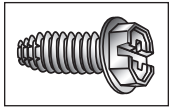

**Grounding Screws**  
page 55

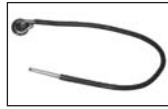

**Grounding Pigtails**  
page 55



**Grounding Clips**  
page 55

### GROUNDING CLAMPS, RODS & ARMORED



**Conduit Hubs**  
page 56



**Ground Rod Clamps**  
page 56



**Ground Clamps**  
page 56



**Armored Ground Clamps**  
page 56



**Ground Clamps with Threaded Hubs**  
page 56

### NUTS

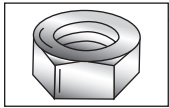

**Hex Nuts & Grade 5**  
pages 57–59



**Flange Whiz Nuts**  
page 59

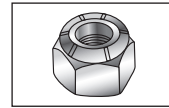

**Nylock Nuts**  
page 60

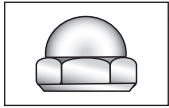

**Cap Nuts**  
page 61

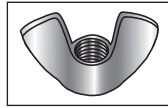

**Wing Nuts**  
page 61

### WASHERS

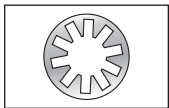

**Toothed Lock Washers, Internal**  
page 62

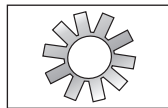

**Toothed Lock Washers, External**  
page 62

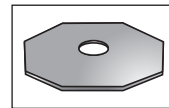

**Sealing, Octagonal & Belleville Washers**  
pages 62–63

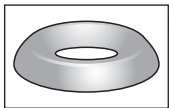

**Finish Cup Washers**  
page 63



**Flat Cut Washers**  
page 64–65



**Fender Washers**  
page 66

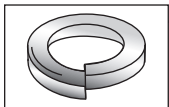

**Split Lock Washers**  
pages 67–68

### BOLTS & LAG SCREWS

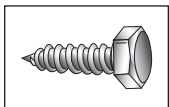

**Hex Lag Screws**  
page 69

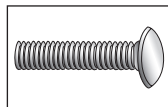

**Carriage Bolts**  
page 70

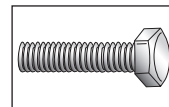

**Hex Head Bolts, Grade 2**  
pages 71–72

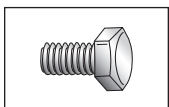

**Hex Cap Screws, Grade 5**  
page 73

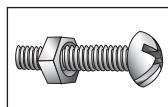

**Stove Bolts, Round Head**  
page 74

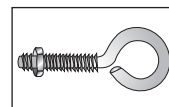

**Eye Bolts**  
page 75

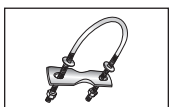

**U-Bolts**  
page 75



### ANCHORS

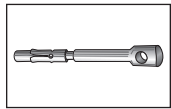

**Acoustical Wedge Anchors**  
page 76



**Double Drywall Anchors**  
page 78

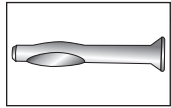

**Flat Head Split Bolt Anchors**  
page 79

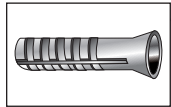

**Lead Anchors**  
page 82



**TOGLER® Snaptoggle® Toggle Bolt Anchors**  
page 84



**Tapcon™ Condrive Installation Tool**  
page 87

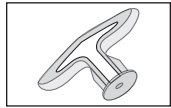

**Plastic Toggle Anchors**  
page 91

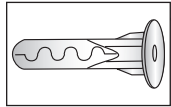

**ALLIGATOR® Anchors**  
page 95

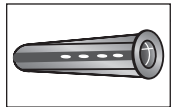

**Red Plastic Conical Anchors**  
pages 97–98

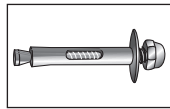

**Sleeve Anchors**  
page 76

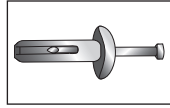

**“Hammer Drive” Anchors**  
page 78

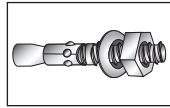

**Trubolt® Wedge Anchors**  
pages 80–81

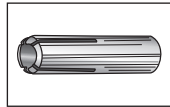

**Steel Drop-In Anchors**  
page 83

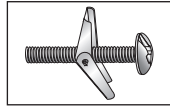

**Toggle Bolts**  
pages 85–86

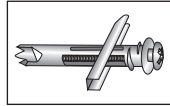

**EZ Toggle™ Anchors**  
page 89

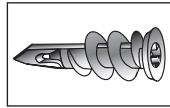

**EZ Ancors™: Zinc, Mini & Plastic**  
pages 91–93

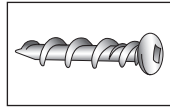

**Pan Head Wall Dog Anchors**  
page 96

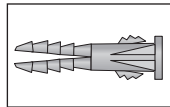

**Yellow Plastic Winged Anchors**  
page 99

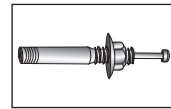

**Strike Set Anchors**  
page 77

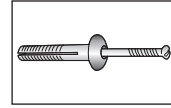

**Nylon Nail-In Anchors**  
page 79

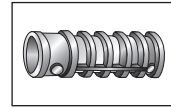

**Lag Screw Shields**  
page 82

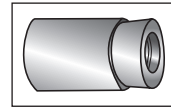

**Lead Machine Screw Anchors**  
page 83

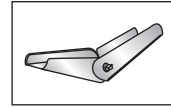

**Toggle Bolt Wings**  
page 86

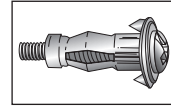

**Hollow Wall Anchors**  
page 90



**Toggler® Snapskru™**  
page 94

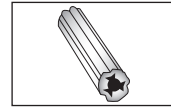

**Green Plug Anchors**  
page 96

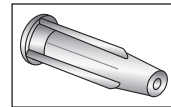

**Expander Anchors**  
page 100

### HANGERS

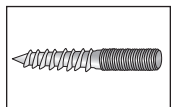

**Hangerbolts**  
page 101



**Hangerbolts Drivers**  
page 101



**SAMMYS® for Wood & Steel**  
pages 102–103



**SAMMYS® Nut Driver**  
pages 102–104



**SAMMYS® for Concrete**  
page 104



**SAMMYS® X-Press**  
page 105

### HANGERS (CONT.)

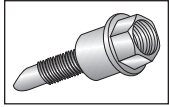

**Hangermate®,  
Metal Applications**  
*page 106*

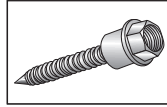

**Hangermate®,  
Wood Applications**  
*page 106*

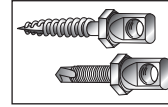

**Hangermate® Brute  
Sidemount Applications**  
*page 107*

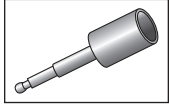

**Hangermate®  
Installation Tools**  
*page 107*

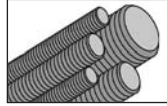

**Threaded Rod**  
*page 107*

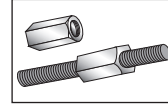

**Hex Rod &  
Reducing Couplings**  
*page 108*



**Tie Wire**  
*page 108*

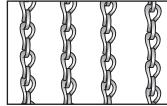

**Jack Chain & Double  
Loop Tenso Chain**  
*page 109*

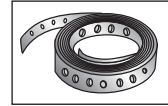

**Plumbers Tape**  
*page 110*



**S-Hooks**  
*page 110*

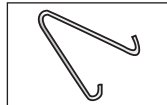

**V-Hooks**  
*page 110*

### PAINTS & CHEMICALS



**Krylon® Inverted  
Marking Paint**  
*page 111*



**Marking Wand**  
*page 112*



**Can Holster**  
*page 112*



**Can Adapter**  
*page 112*



**Krylon® Acrylic  
Enamel Paint**  
*page 113*



**Sprayon®  
Contact Cleaners**  
*page 116*



**Sprayon® Cleaners &  
Degreasers**  
*page 117*



**Sprayon® Lubricants**  
*page 118*



**Sprayon® & Krylon®  
Corrosion Inhibitors &  
Insulating Varnishes**  
*page 119*



**Sprayon® General  
Purpose & Glass Cleaners**  
*page 120*



**Krylon® Repositionable  
Adhesive**  
*page 121*



**Sprayon® Insecticides  
& Insect Repellents**  
*page 121*



**Dura-Ink 15 Marker**  
*page 122*

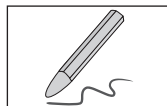

**Lumber Crayons**  
*page 122*



**White Lightning®  
Silicone Sealant**  
*page 124*



**EZ-Thrust Caulk Gun**  
*page 124*



**Sprayon®  
Clear Silicone**  
*page 124*



**Tri-Flow® Lubricants**  
*page 124*



**White Lightning®  
Stop Gap!™**  
*page 125*



**Wet Patch  
Roof Cement**  
*page 125*



**E-6000 Industrial  
Adhesive**  
*page 125*



**Dark Cutting Oil**  
*page 126*



**Duct Seal Compound**  
*page 126*

### RAGS



**All Purpose Rags**  
page 127



**Scrubs-in-a-Bucket®**  
page 127

### FIRESTOP PRODUCTS



**Firestop Putty Pad**  
page 128



**Lectra-Stop**  
page 128



**Firestop Gaskets**  
page 128



**Firestop Putty Sticks**  
page 129



**Firestop Caulk**  
page 129



**Sausage Firestop Caulking Gun**  
page 129



**Firestop Pillows**  
page 129

### TOOLS • SHOVELS, RAKES, SLEDGE HAMMERS & FIBERGLASS HANDLED TOOLS



**Shovels**  
pages 130–131



**Rakes**  
pages 130–131



**Irrigating/Floral**  
pages 130–131



**Spades**  
pages 130–131



**Sledge Hammers**  
pages 130–131



**Pick Mattock**  
pages 130–131



**Utility Probe**  
pages 130–131



**Post Hole Digger**  
pages 130–131



**All Purpose Bar with Tamper**  
pages 130–131

### TOOLS • TOOL BAGS & ACCESSORIES



**Electrician's Comfort Combos**  
pages 132–133



**Pouches & Bags**  
pages 132–133



**Belts & Suspenders**  
page 132



**Meter Pouch**  
page 132



**Drill Pouch**  
page 132



**Hammer Holder**  
page 132



**Blade Guard**  
page 132



**Phone Case**  
page 132



**Tape Clip**  
page 132

### TOOLS • SCREWDRIVERS, NUT DRIVERS & ACCESSORIES



**Megapro®  
15-in-1 Screwdrivers**  
*page 134*



**Megapro® Quick  
Change Screwdriver**  
*page 135*



**Megapro®  
16-in-1 Tamperproof  
Screwdriver**  
*page 135*



**6-in-1 Economy  
Screwdriver**  
*page 136*



**13-in-1 Ratcheting  
Screwdriver**  
*page 136*



**14-in-1 HVAC  
Screwdriver**  
*page 136*



**15-in-1 Tamperproof 2  
Screwdriver**  
*page 136*



**15-in-1 Shaftlock 2  
Screwdriver**  
*page 137*



**Spanner Drive &  
Un-Do It Tool**  
*page 137*



**Square Drive  
Screwdrivers**  
*page 137*



**Screwdrivers**  
*page 138*



**Nut Drivers**  
*page 138*



**Tamperproof  
29-in-1 Driver Kit**  
*page 139*



**Dial-A-Bit Kit**  
*page 140*



**Magnetic Bit Holder**  
*page 140*

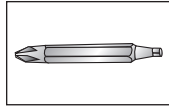

**Double Ended  
Power Bit**  
*page 140*



**Magnetizer/  
Demagnetizer**  
*page 140*

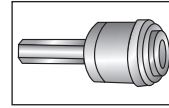

**Quick Change  
Drill Adapter**  
*page 140*

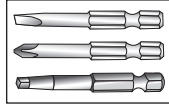

**Hex Power Bits**  
*pages 141–142*

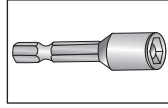

**Hex Driver Bits**  
*page 142*



**Tamperproof  
Insert Bits**  
*page 143*

### TOOLS • DRILL BITS

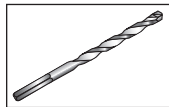

**Tapcon™ Carbide-Tipped  
Masonry Drill Bits**  
*page 87*

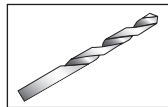

**High Speed  
Jobber Drills**  
*pages 144–145*

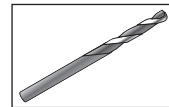

**Trinado Heavy Duty  
Drills & Drill Index Set**  
*page 146*



**Dial-A-Drill Set**  
*page 147*



**Hex Drill Set**  
*page 147*



**Special Drill Sets**  
*page 147*

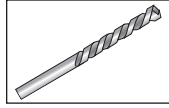

**Straight Shank  
Carbide Drill Bits**  
*page 148*

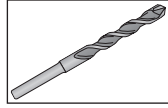

**Rotary/Precussion  
Carbide Drill Bits**  
*page 148*

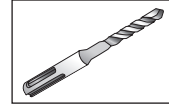

**SDS Rotary/Hammer  
Carbide Drill Bits**  
*page 148*

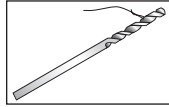

**Bell Hanger Bits**  
*page 149*

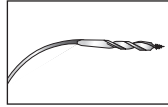

**Flex Shank Drill Bits**  
*page 149*

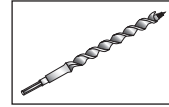

**Electrician's  
Power Bits**  
*page 149*

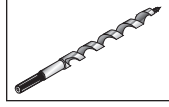

**Ship Auger Bits**  
*page 150*

### TOOLS • DRILL BITS (CONT.)

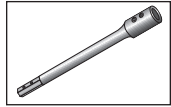

**Auger Bit Extensions**  
page 150

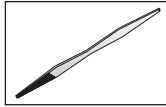

**Auger Sharpening File**  
page 150

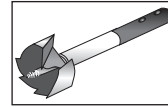

**Sawtooth Self-Feeding Bits**  
page 151



**Speedbor 2000™ Wood Bits**  
page 151

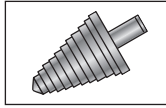

**Step Drills**  
page 152

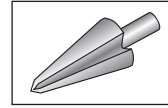

**Cone Bits**  
page 152

### TOOLS • HOLE SAWS, ARBORS & KITS



**Hole Saw Arbors**  
page 152

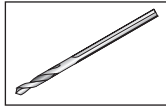

**Pilot Drills**  
page 152



**Variable Pitch Hole Saws**  
page 153



**Hole Saw Kits**  
pages 153–154



**Carbide Grit Hole Saws**  
page 154

### TOOLS • TAPS & SCREW EXTRACTORS

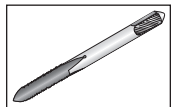

**Carbon Steel Taps**  
page 155

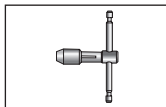

**Carbon Steel Tap Wrenches**  
page 155



**Carbon Steel Taps & Drill Set**  
page 155



**Hex Shank Taps**  
page 155



**Screw Extractor & Drill Bit Set**  
page 156



**Damaged Screw Remover Set**  
page 156

### TOOLS • SAW BLADES



**Drywall Jab Saw**  
page 156

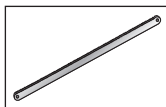

**Hack Saw Blades**  
page 157



**Hack Saw Frame**  
page 157

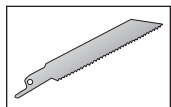

**Reciprocating Saw Blades**  
page 157



**PVC Cable Saws**  
page 157

### TOOLS • MISCELLANEOUS

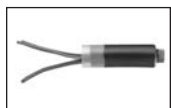

**Urseal Splice Kits**  
page 167



**Tape Measure**  
page 168



**Quickie Tie-Down Straps**  
page 168



**Tarp Straps**  
page 168

### TOOLS • KNIVES & ACCESSORIES



**Accusharp Knife Sharpener**  
page 158



**QuickBlade™ Ergonomic Utility Knife**  
page 158



**Titan™ Folding Pocket Utility Knife**  
page 158



**SOG Multi-Tools**  
page 159



**SOG Folding Knives**  
pages 160–163



**SOG Fixed Blade Knives**  
pages 164–165



**SOG Entrenching Tool**  
page 165

### TOOLS • ROPE, PISTONS, LINE PACKAGES, PULLING TAPE & BLOW TWINE



**Yellow Polypropylene Pull Rope**  
page 169



**Polyester Pulling Tape/ Mule Tape**  
page 169



**Line Packages**  
page 170



**Polyester Conduit Measuring Tape**  
page 170



**Polypropylene Blow Twine**  
page 170



**Foam Conduit Pistons**  
page 171

### TOOLS • CABLE MANAGEMENT



**Receptical Shim**  
page 171



**Non-Metallic Sheathed Cable Connectors**  
page 171



**Steel Stud Bushings**  
page 172



**Anti-Short Bushings**  
page 172



**Knock-Out Bushings**  
page 172

### TOOLS • TAPE

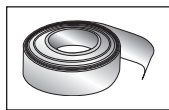

**Color-Coded PVC Electrical Tape**  
page 173

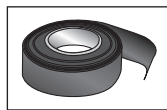

**Black PVC Electrical Tape**  
page 173

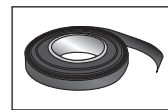

**Rubber Tape**  
page 173

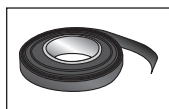

**Friction Tape**  
page 173

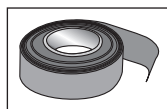

**Duct Tape**  
page 174

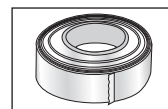

**Carton Sealing Tape**  
page 174

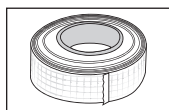

**Strapping Tape**  
page 174



**Pipe Wrap**  
page 174

### SAFETY • BARRICADE TAPE



**Barricade & Caution Tape**  
page 175



**Underground Burial Tape**  
page 175



**Underground Detectable Tape**  
page 175

### SAFETY • SAFETY GLASSES



**Crossfire® Safety Glasses**  
pages 176–177



**Nemesis™ Safety Glasses**  
page 178



**Smith & Wesson® Safety Glasses**  
page 179



**Hellraiser™ Safety Glasses**  
page 179



**OTG – Over The Glasses**  
page 179

### SAFETY • SAFETY PRODUCTS



**Disposable Dust Masks**  
page 180



**Hearing Protection**  
page 180

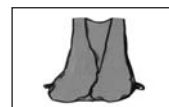

**Safety Vests**  
page 180



**Charger™ Hard Hats**  
page 181



**Block Head Hard Hats**  
page 181



**Hard Hat Liners**  
page 181



**First Aid Kits**  
page 182

### SAFETY • WORK GLOVES



**Split Leather Work Glove**  
page 183



**1927® Cold Weather Grain Pigskin Glove**  
page 183



**Split Leather Drivers Glove**  
page 183



**Unlined Deerskin Drivers Glove**  
page 183



**Unlined Grain Pigskin Drivers Glove**  
page 183



**Grain Leather Drivers Glove**  
page 183



**Unlined Brown Jersey Glove**  
page 183



**Lined Brown Jersey Glove**  
page 183











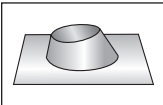

**Latex Coated Knit Glove**  
page 183

### SAFETY • WORK GLOVES

	<b>Warm Grip Latex Work Glove</b> <i>page 184</i>		<b>Frostbreaker® Thermal Latex Gripping Glove</b> <i>page 184</i>		<b>Nitrile Palm Coated Glove</b> <i>page 184</i>
	<b>White String Knit Glove</b> <i>page 184</i>		<b>PVC Dipped Glove</b> <i>page 184</i>		<b>White Canvas Glove</b> <i>page 184</i>
	<b>Fingerless Ragg Wool Glove</b> <i>page 184</i>		<b>Kevlar® Lined Glove</b> <i>page 184</i>		<b>Pro-Grip Mechanic's Plus Glove</b> <i>page 185</i>
	<b>Pro-Grip Half Finger Work Glove</b> <i>page 185</i>		<b>Pro-Grip Full Finger Work Glove</b> <i>page 185</i>		<b>Pro-Grip Winter Plus Glove</b> <i>page 185</i>
	<b>Pro-Grip Mesh General Utility Glove</b> <i>page 185</i>				

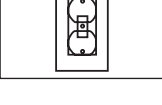
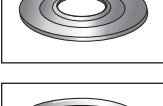
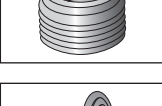
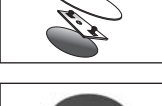
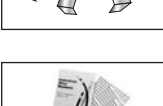
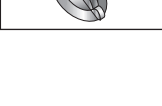
### MISCELLANEOUS

	<b>Roof Jacks</b> <i>page 186</i>		<b>Service Entrance Caps</b> <i>page 186</i>		<b>Pre-Kuts Plastic Sleepers</b> <i>page 186</i>
	<b>Quick-Caps &amp; Quick Spacers</b> <i>page 187</i>		<b>Cable Tensioning Tool &amp; Tie Kits</b> <i>page 187</i>		<b>Mounting Bases</b> <i>page 188</i>
	<b>Cable Ties</b> <i>page 188</i>		<b>Mounting Ties</b> <i>page 188</i>		<b>Wall Plate Insulating Gaskets</b> <i>page 189</i>
	<b>Reducing Washers</b> <i>page 189</i>		<b>Reducing Bushings</b> <i>page 189</i>		<b>Ceiling Cover Plate</b> <i>page 190</i>
	<b>Snap-In Knock-Out Seals</b> <i>page 190</i>		<b>3-Piece Knock-Out Seals</b> <i>page 190</i>		<b>Non-Metallic Knock-Out Seals</b> <i>page 190</i>
	<b>Wire &amp; Cable Marker Books</b> <i>pages 191-192</i>				



## Fasteners 14–110

### SCREWS

- 14–22 Sheet Metal Screws
- 23 Metal Piercing Stud Screws
- 24 Framing Screws
- 25–28 Tek Self-Drilling Screws
- 29–37 Machine Screws
- 38 Plate Screws
- 39–41 Wood Screws
- 42 Particle Board Screws
- 43–44 Drywall Screws
- 45 Deck Screws
- 46–47 Tamperproof Sheet Metal Screws
- 48–49 Tamperproof Machine Screws
- 50–51 Cap Screws
- 52 Brass Screws
- 53 Screw Hooks & Eyes
- 54 Screw & Acoustical Eye Lags
- 87–88 Tapcon™ Concrete Screws

### GROUNDING

- 55 Grounding Screws, Pigtailed & Clips
- 56 Grounding Clamps, Rods & Armored with Hubs

### NUTS/WASHERS

- 57–59 Hex Nuts
- 59 Flange Whiz Nuts
- 59 Grade 5 Hex Nuts
- 60 Nylock Hex Nuts
- 61 Cap & Wing Nuts
- 62 Lock Washers, Sealing & Octagonal Washers
- 63 Belleville & Finish Cup Washers
- 64–65 Flat Cut Washers
- 66 Fender Washers
- 67–68 Split Lock Washers

### BOLTS

- 69 Hex Lag Screws
- 70 Carriage Bolts
- 71–72 Hex Head Bolts
- 73 Hex Cap Screws
- 74 Stove Bolts
- 75 Eye & U-Bolts

### ANCHORS

- 76 Acoustical Wedge & Sleeve Anchors
- 77–81 Concrete/Masonry Anchors
- 82 Screw Anchors
- 83 Bolt Anchors
- 84, 90 Hollow Wall Anchors
- 85–86 Toggle Bolts & Wings
- 89 EZ Toggle™ Ancors
- 91 Toggler® Plastic Anchors & EZ Ancors™
- 92 EZ Mini Ancors™
- 93 White Plastic EZ Ancors™
- 94 SnapSkru™ Self-Drilling Drywall Anchors
- 95 Toggler® Alligator® Solid Wall Anchors
- 96 Green Plug & Pan Head Wall Dog Anchors
- 97–98 Red Plastic Conical Anchors
- 99 Yellow Winged Anchors
- 100 Expander Anchors

### HANGER

- 101 Hangerbolts & Hangerbolt Drivers
- 102–105 Sammy's® Anchoring Systems
- 106–110 Fixture Hanging Hardware

## Paints & Chemicals 111–129

- 111 Inverted Marking Paint
- 112 Color Selection Guide
- 112 Paint Accessories
- 113 Acrylic Enamel Paint
- 114–115 Contact Cleaner Selection Guide
- 116 Contact Cleaners
- 117 Electrical & Electronic Cleaners & Degreasers
- 118 Lubricants
- 119 Corrosion Inhibitors & Insulating Varnishes
- 120 General Purpose & Glass Cleaner
- 121 Repositionable Adhesive & Insect Repellents
- 122 Markers
- 123 Paint & Chemicals Technical Glossary
- 124–125 Sealants & Adhesives
- 124 Tri-Flow Lubricant
- 126 Cutting Oil & Duct Seal Compound
- 127 All Purpose Rags & Scrubs
- 128–129 Firestop Products

## Tools 130–174

- 130–131 Fiberglass Handled Tools
- 132–133 Tool Bags & Accessories
- 134–135 Megapro® Screwdrivers
- 136–138 Screwdrivers
- 137 Spanner Drive & Un-Do It Tool
- 138 Nut Drivers
- 139 Tamperproof Driver Bits
- 140 Dial-A-Bit Kit & Driver Bit Accessories
- 141–142 Hex Power Bits
- 142 Hex Driver Bits
- 143 Tamperproof Insert Bits
- 144–145 High Speed Jobber Drills
- 146 Trinado Heavy-Duty Drills
- 147 Drill Bits
- 148 Carbide Drill Bits
- 149–151 Wood Bits
- 152 Step Drills, Cone Bits, Hole Saw Arbors & Pilot Drills
- 153–154 Hole Saws
- 155 Snap Steel & Hex Shank Taps
- 156 Screw Extractors
- 156–157 Drywall Jab Saw & Saw Blades
- 158 Knife Sharpeners & Utility Knives
- 159 SOG Multi-Tools
- 160–163 SOG Folding Knives
- 164–165 SOG Fixed Knives
- 165 SOG Entrenching Tool
- 166 SOG Warranty Information
- 167 Uraseal Splice Kits
- 168 Tape Measure
- 168 Tie Down Straps
- 169 Polypropylene Pull Rope & Pulling/Mule Tape
- 170 Conduit Tape, Blow Twine & Line Packages
- 171 Foam Conduit Pistons
- 171–172 Cable Management
- 173–174 Tape
- 174 Pipe Wrap

## Safety 175–185

- 175 Barricade Tape
- 176–177 Crossfire® Safety Glasses
- 178–179 Safety Glasses
- 180 Dust Masks, Hearing Protection & Safety Vests
- 181 Hard Hats & Liners
- 182 First Aid Kits
- 183–185 Work Gloves

## Miscellaneous 186–192

- 186 Roof Jacks, Service Entrance Caps & Pre-Kuts
- 187 Pipe Fasteners
- 187–188 Cable Management
- 189 Gaskets, Reducing Washers & Bushings
- 190 Ceiling Cover Plate & Knock-Out Seals
- 191–192 Marker Books



### PAN HEAD SHEET METAL SCREWS • SQUARE DRIVE • ZINC

FASTENERS • SCREWS

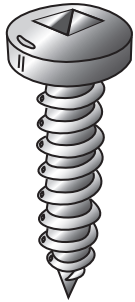

▲ Contact customer service for gravity feed jar availability.

\*These items are packaged in cardboard boxes.

For bulk packaging, contact customer service for quantities and availability.

		Best Merchandising Option					
		Plastic Box		Gravity Feed Jar		Job Jar	
Size	Bit Size	Part #	Box Qty/ Std Pk	Part #	Jar Qty/ Std Pk	Part #	Jar Qty
4 x 3/8	#0	10406	100/500	▲		—	
4 x 1/2		10408	100/500	▲		—	
4 x 5/8		10410	100/500	▲		—	
4 x 3/4		10412	100/500	▲		—	
6 x 1/4	#1	10604	100/500	▲		—	
6 x 3/8		10606	100/500	▲		—	
6 x 1/2		10608	100/500	▲		—	
6 x 5/8		10610	100/500	▲		—	
6 x 3/4		10612	100/500	10612J	100/1200	—	
6 x 1		10616	100/500	10616J	100/1200	—	
6 x 1 1/4		10620	100/500	▲		—	
6 x 1 1/2		10624	100/500	10624J	100/1200	—	
6 x 1 3/4		10628	100/500	▲		—	
6 x 2		10632	100/500	▲		—	
8 x 3/8	#2	10806	100/500	10806J	100/600	—	
8 x 1/2		10808	100/500	10808J	100/600	—	
8 x 5/8		10810	100/500	▲		—	
8 x 3/4		10812	100/500	10812J	100/1200	10812-6	1000
8 x 1		10816	100/500	10816J	100/1200	10816-6	750
8 x 1 1/4		10820	100/500	10820J	100/1200	10820-6	500
8 x 1 1/2		10824	100/500	10824J	100/600	10824-6	500
8 x 1 3/4		10828	50/250	▲		—	
8 x 2		10832	50/250	10832J	100/600	—	
8 x 2 1/2		10840	*100	10840J	100/600	—	
8 x 3		10848	*100	▲		—	
10 x 1/2	#2	11008	100/500	11008J	100/1200	11008-6	1000
10 x 5/8		11010	100/500	11010J	100/1200	—	
10 x 3/4		11012	100/500	11012J	100/1200	11012-6	750
10 x 1		11016	100/500	11016J	100/1200	11016-6	500
10 x 1 1/4		11020	100/500	11020J	100/1200	11020-6	500
10 x 1 1/2		11024	50/250	11024J	100/600	11024-6	350
10 x 1 3/4		11028	50/250	▲		—	
10 x 2		11032	50/250	11032J	100/600	11032-6	250
10 x 2 1/2		11040	*100	11040J	100/600	—	
10 x 3		11048	*100	11048J	100/600	—	
12 x 1/2	#3	11208	100/500	11208J	100/1200	—	
12 x 5/8		11210	100/500	▲		—	
12 x 3/4		11212	100/500	11212J	100/1200	—	
12 x 1		11216	100/500	11216J	100/1200	—	
12 x 1 1/4		11220	50/250	11220J	100/600	—	
12 x 1 1/2		11224	50/250	11224J	100/600	—	
12 x 1 3/4		11228	50/250	▲		—	
12 x 2		11232	50/250	11232J	100/600	—	
12 x 2 1/2		11240	*100	11240J	100/600	—	
12 x 3		11248	*100	11248J	100/600	—	

Continued on next page.

## PAN HEAD SHEET METAL SCREWS • SQUARE DRIVE • ZINC (CONT.)

		Best Merchandising Option					
		Plastic Box	Gravity Feed Jar	Job Jar			
Size	Bit Size	Part #	Box Qty/ Std Pk	Part #	Jar Qty/ Std Pk	Part #	Jar Qty
14 x 1/2	#3	11408	100/500	▲		—	
14 x 5/8		11410	100/500	▲		—	
14 x 3/4		11412	100/500	▲		—	
14 x 1		11416	50/250	▲		—	
14 x 1 1/4		11420	50/250	▲		—	
14 x 1 1/2		11424	50/250	▲		—	
14 x 1 3/4		11428	50/250	▲		—	
14 x 2		11432	25/125	▲		—	
14 x 2 1/2		11440	*100	▲		—	
14 x 3		11448	*100	▲		—	



FASTENERS • SCREWS

		Kits			
Part #	Description				
<b>39551</b> (396 Piece Kit)	<b>#6 Pan Head Sheet Metal Screw Square Drive Kit</b> Includes a #1-2" Square Drive Power Bit				
	1/2" (100 Pieces)	1" (75 Pieces)	1 1/2" (40 Pieces)		
	3/4" (100 Pieces)	1 1/4" (50 Pieces)	2" (30 Pieces)		
<b>39552</b> (316 Piece Kit)	<b>#8 Pan Head Sheet Metal Screw Square Drive Screw Kit</b> Includes a #2-2" Square Drive Power Bit				
	1/2" (100 Pieces)	1" (50 Pieces)	1 1/2" (35 Pieces)		
	3/4" (60 Pieces)	1 1/4" (40 Pieces)	2" (30 Pieces)		
<b>39553</b> (231 Piece Kit)	<b>#10 Pan Head Sheet Metal Screw Square Drive Screw Kit</b> Includes a #2-2" Square Drive Power Bit				
	1/2" (70 Pieces)	1" (35 Pieces)	1 1/2" (25 Pieces)		
	3/4" (50 Pieces)	1 1/4" (30 Pieces)	2" (20 Pieces)		

▲ Contact customer service for gravity feed jar availability.  
\*These items are packaged in cardboard boxes.

For bulk packaging, contact customer service for quantities and availability.

## PAN HEAD SHEET METAL SCREWS • SQUARE DRIVE • 18-8 STAINLESS STEEL

FASTENERS • SCREWS

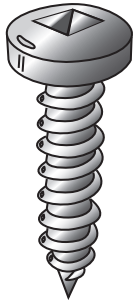

		Plastic Box		Best Merchandising Option	
				Gravity Feed Jar	
Size	Bit	Part #	Box Qty/ Std Pk	Part #	Jar Qty/ Std Pk
6 x 1/2	#1	70608	100/500		▲
6 x 3/4		70612	100/500		▲
6 x 1		70616	100/500		▲
6 x 1 1/4		70620	100/500		▲
8 x 1/2	#2	70808	100/500		▲
8 x 5/8		70810	100/500		▲
8 x 3/4		70812	100/500		▲
8 x 1		70816	100/500		▲
8 x 1 1/4		70820	100/500		▲
8 x 1 1/2		70824	100/500		▲
8 x 2		70832	50/250		▲
10 x 1/2	#2	71008	100/500		▲
10 x 5/8		71010	100/500		▲
10 x 3/4		71012	100/500		▲
10 x 1		71016	100/500	71016J	100/1200
10 x 1 1/4		71020	100/500	71020J	100/1200
10 x 1 1/2		71024	50/250	71024J	50/600
10 x 2		71032	50/250	71032J	50/600
10 x 2 1/2		71040	*100		▲
12 x 3/4	#3	71212	100		▲
12 x 1		71216	100		▲
12 x 1 1/4		71220	50/250		▲
12 x 1 1/2		71224	50/250		▲
12 x 2		71232	50/250		▲
12 x 2 1/2		71240	*100		▲
14 x 3/4	#3	71412	100		▲
14 x 1		71416	50/250		▲
14 x 1 1/4		71420	50/250		▲
14 x 1 1/2		71424	50/250		▲
14 x 2		71432	25/125		▲
14 x 2 1/2		71440	*100		▲
14 x 3		71448	*100		▲

▲ Contact customer service for gravity feed jar availability.  
 \*These items are packaged in cardboard boxes.  
 ▽ Harsh Environment Product

For bulk packaging, contact customer service for quantities and availability.

## PAN HEAD SHEET METAL SCREWS • PHILLIPS/SLOTTED COMBO • ZINC

		Best Merchandising Option					
		Plastic Box	Gravity Feed Jar	Job Jar			
Size	Bit Size	Part #	Box Qty/ Std Pk	Part #	Jar Qty/ Std Pk	Part #	Jar Qty
6 x 1/2	#1	18609	100/500	18609J	100/1200	—	—
6 x 3/4		18613	100/500	18613J	100/1200	—	—
6 x 1		18617	100/500	18617J	100/1200	—	—
6 x 1 1/4		18621	100/500	18621J	100/1200	—	—
6 x 1 1/2		18625	100/500	18625J	100/1200	—	—
8 x 1/2	#2	18809	100/500	18809J	100/1200	—	—
8 x 3/4		18813	100/500	18813J	100/1200	18813-6	1000
8 x 1		18817	100/500	18817J	100/1200	18817-6	750
8 x 1 1/4		18821	100/500	18821J	100/1200	18821-6	500
8 x 1 1/2		18825	100/500	18825J	100/1200	—	—
8 x 2		18833	50/250	18833J	100/600	—	—
10 x 1/2	#2	19009	100/500	19009J	100/1200	19009-6	1000
10 x 3/4		19013	100/500	19013J	100/1200	19013-6	750
10 x 1		19017	100/500	19017J	100/1200	19017-6	500
10 x 1 1/4		19021	100/500	19021J	100/1200	19021-6	500
10 x 1 1/2		19025	50/250	19025J	100/600	19025-6	350
10 x 2		19033	50/250	19033J	100/600	19033-6	250
10 x 2 1/2		19041	*100	19041J	100/600	—	—
10 x 3		19049	*100	19049J	100/600	—	—
12 x 1/2	#3	19209	100/500	19209J	100/1200	—	—
12 x 3/4		19213	100/500	19213J	100/1200	—	—
12 x 1		19217	100/500	19217J	100/1200	—	—
12 x 1 1/4		19221	50/250	19221J	100/600	—	—
12 x 1 1/2		19225	50/250	19225J	100/600	—	—
12 x 2		19233	50/250	19233J	100/600	—	—
12 x 2 1/2		19241	*100	19241J	100/600	—	—
12 x 3		19249	*100	19249J	100/600	—	—
14 x 3/4	#3	19413	100/500	19413J	100/1200	—	—
14 x 1		19417	50/250	19417J	100/600	—	—
14 x 1 1/4		19421	50/250	19421J	100/600	—	—
14 x 1 1/2		19425	50/250	19425J	100/600	—	—
14 x 2		19433	25/125	19433J	100/600	—	—



**FASTENERS • SCREWS**

\* These items are packaged in cardboard boxes.

For bulk packaging, contact customer service for quantities and availability.

### Kits

Part #	Description		
<b>39556</b> (316 Piece Kit)	<b>#8 Pan Head Sheet Metal Screw Combo Phillips/Slotted Kit</b> Includes a #2-2" Phil Power Bit		
	1/2" (100 Pieces)	1" (50 Pieces)	1 1/2" (35 Pieces)
	3/4" (60 Pieces)	1 1/4" (40 Pieces)	2" (30 Pieces)
<b>39557</b> (231 Piece Kit)	<b>#10 Pan Head Sheet Metal Screw Combo Phillips/Slotted Kit</b> Includes a #2-2" Phil Power Bit		
	1/2" (70 Pieces)	1" (35 Pieces)	1 1/2" (25 Pieces)
	3/4" (50 Pieces)	1 1/4" (30 Pieces)	2" (20 Pieces)

## PAN HEAD SHEET METAL SCREWS • PHILLIPS • 18-8 STAINLESS STEEL

FASTENERS • SCREWS



		Best Merchandising Option					
		Plastic Box		Gravity Feed Jar		Job Jar	
Size	Bit Size	Part #	Box Qty/ Std Pk	Part #	Jar Qty/ Std Pk	Part #	Jar Qty
10 x 3/4	#2	81012SS	100/500	81012SSJ	100/1200	—	—
10 x 1		81016SS	100/500	81016SSJ	100/1200	—	—
10 x 1 1/4		81020SS	100/500	81020SSJ	100/1200	—	—
10 x 1 1/2		81024SS	50/250	81024SSJ	100/600	—	—
10 x 2		81032SS	50/250	81032SSJ	100/600	—	—

Harsh Environment Product

## HEX WASHER HEAD SHEET METAL SCREWS • PHILLIPS/SLOTTED COMBO • ZINC



		Best Merchandising Option					
		Plastic Box		Gravity Feed Jar		Job Jar	
Size	Head Size	Part #	Box Qty/ Std Pk	Part #	Jar Qty/ Std Pk	Part #	Jar Qty
10 x 1/2	5/16"	77008	100/500	77008J	100/1200	77008-6	1000
10 x 3/4		77012	100/500	77012J	100/1200	77012-6	750
10 x 1		77016	100/500	77016J	100/1200	77016-6	500
10 x 1 1/4		77020	100/500	77020J	100/600	77020-6	500
10 x 1 1/2		77024	50/250	77024J	100/600	77024-6	350
10 x 2		77032	50/250	77032J	100/600	77032-6	250

Kits			
Part #	Description		
39562 (211 Piece Kit)	#10 HWH Sheet Metal Screw Combo Phillips/Slotted Kit Includes a 5/16" Hex Driver		
	1/2" (60 Pieces)	1" (35 Pieces)	1 1/2" (25 Pieces)
	3/4" (40 Pieces)	1 1/4" (30 Pieces)	2" (20 Pieces)

For bulk packaging, contact customer service for quantities and availability.

## HEX WASHER HEAD SHEET METAL SCREWS • SLOTTED • ZINC

		Best Merchandising Option					
		Plastic Box	Gravity Feed Jar	Job Jar			
Size	Bit Size	Part #	Box Qty/ Std Pk	Part #	Jar Qty/ Std Pk	Part #	Jar Qty
6 x 1/2	1/4"	76608	100/500	▲		—	
6 x 5/8		76610	100/500	▲		—	
6 x 3/4		76612	100/500	▲		—	
6 x 1		76616	100/500	76616J	100/1200	—	
6 x 1 1/4		76620	100/500	▲		—	
6 x 1 1/2		76624	100/500	▲		—	
8 x 1/2	1/4"	76808	100/500	76808J	100/1200	—	
8 x 5/8		76810	100/500	▲		—	
8 x 3/4		76812	100/500	76812J	100/1200	—	
8 x 1		76816	100/500	76816J	100/1200	—	
8 x 1 1/4		76820	100/500	76820J	100/1200	—	
8 x 1 1/2		76824	100/500	76824J	100/1200	—	
8 x 2		76832	50/250	76832J	100/600	—	
8 x 2 1/2		76840	*100	76840J	100/600	—	
8 x 3		76848	*100	76848J	100/600	—	
10 x 5/8	5/16"	77010	100/500	▲		—	
10 x 1 3/4		77028	50/250	▲		—	
10 x 2 1/2		77040	*100	77040J	100/600	—	
10 x 3		77048	*100	77048J	100/600	—	
12 x 1/2	5/16"	77208	100/500	77208J	100/1200	—	
12 x 3/4		77212	100/500	77212J	100/1200	—	
12 x 1		77216	100/500	77216J	100/1200	—	
12 x 1 1/4		77220	50/250	77220J	100/600	—	
12 x 1 1/2		77224	50/250	77224J	100/600	—	
12 x 2		77232	50/250	77232J	100/600	—	
12 x 2 1/2		77240	*100	▲		—	
12 x 3		77248	*100	77248J	100/600	—	
14 x 1/2	3/8"	77408	100/500	▲		—	
14 x 3/4		77412	100/500	▲		—	
14 x 1		77416	50/250	77416J	100/600	—	
14 x 1 1/4		77420	50/250	77420J	50/300	—	
14 x 1 1/2		77424	50/250	▲		—	
14 x 2		77432	25/125	77432J	100/600	—	
14 x 2 1/2		77440	*100	77440J	100/600	—	
14 x 3		77448	*100	77448J	100/600	—	



**FASTENERS • SCREWS**

▲ Contact customer service for gravity feed jar availability.

\* These items are packaged in cardboard boxes.

For bulk packaging, contact customer service for quantities and availability.

		Kits			
Part #	Description				
39561 (286 Piece Kit)	<b>#8 HWH Sheet Metal Screw Slotted Kit</b> Includes a 1/4" Hex Driver				
	1/2" (100 Pieces)	1" (40 Pieces)	1 1/2" (25 Pieces)		
	3/4" (60 Pieces)	1 1/4" (35 Pieces)	2" (25 Pieces)		

## ROUND WASHER HEAD SHEET METAL SCREWS • SQUARE DRIVE • ZINC

FASTENERS • SCREWS



▲ Contact customer service for gravity feed jar availability.

\*These items are packaged in cardboard boxes.

For bulk packaging, contact customer service for quantities and availability.

		Best Merchandising Option					
		Plastic Box		Gravity Feed Jar		Job Jar	
Size	Bit Size	Part #	Box Qty/ Std Pk	Part #	Jar Qty/ Std Pk	Part #	Jar Qty
8 x ½	#2	<b>14808</b>	100/500	<b>14808J</b>	100/1200	—	—
8 x ⅝		<b>14810</b>	100/500	<b>14810J</b>	100/1200	—	—
8 x ¾		<b>14812</b>	100/500	<b>14812J</b>	100/1200	<b>14812-6</b>	1000
8 x 1		<b>14816</b>	100/500	<b>14816J</b>	100/1200	<b>14816-6</b>	750
8 x 1¼		<b>14820</b>	100/500	<b>14820J</b>	100/1200	<b>14820-6</b>	500
8 x 1½		<b>14824</b>	100/500	<b>14824J</b>	100/1200	—	—
8 x 1¾		<b>14828</b>	50/250	▲		—	—
8 x 2		<b>14832</b>	50/250	<b>14832J</b>	100/600	—	—
8 x 2½		<b>14840</b>	*100	▲		—	—
8 x 3		<b>14848</b>	*100	▲		—	—
10 x ½	#2	<b>15008</b>	100/500	<b>15008J</b>	100/1200	<b>15008-6</b>	1000
10 x ¾		<b>15012</b>	100/500	<b>15012J</b>	100/1200	<b>15012-6</b>	750
10 x 1		<b>15016</b>	100/500	<b>15016J</b>	100/1200	<b>15016-6</b>	500
10 x 1¼		<b>15020</b>	100/500	<b>15020J</b>	100/1200	<b>15020-6</b>	500
10 x 1½		<b>15024</b>	50/250	<b>15024J</b>	100/600	<b>15024-6</b>	350
10 x 2		<b>15032</b>	50/250	<b>15032J</b>	100/600	<b>15032-6</b>	250
10 x 3		<b>15048</b>	*100	▲		—	—
12 x ¾	#3	<b>15212</b>	100/500	▲		—	—
12 x 1		<b>15216</b>	100/500	▲		—	—



Kits

Part #	Description		
<b>39565</b> (261 Piece Kit)	<b>#8 RWH Sheet Metal Screw Square Drive Kit</b> Includes a #2-2" Power Bit		
	½" (80 Pieces)	1" (45 Pieces)	1½" (30 Pieces)
	¾" (50 Pieces)	1¼" (30 Pieces)	2" (25 Pieces)
<b>39566</b> (211 Piece Kit)	<b>#10 RWH Sheet Metal Screw Square Drive Kit</b> Includes a #2-2" Power Bit		
	½" (60 Pieces)	1" (35 Pieces)	1½" (22 Pieces)
	¾" (50 Pieces)	1¼" (25 Pieces)	2" (18 Pieces)



## FLAT HEAD SHEET METAL SCREWS • SQUARE DRIVE • ZINC

		Best Merchandising Option					
		Plastic Box	Gravity Feed Jar	Job Jar			
Size	Bit Size	Part #	Box Qty/ Std Pk	Part #	Jar Qty/ Std Pk	Part #	Jar Qty
6 x 3/8	#1	12606	100/500	▲		—	
6 x 1/2		12608	100/500	▲		—	
6 x 5/8		12610	100/500	▲		—	
6 x 3/4		12612	100/500	12612J	100/1200	—	
6 x 1		12616	100/500	12616J	100/1200	—	
6 x 1 1/4		12621	100/500	▲		—	
6 x 1 1/2		12625	100/500	▲		—	
6 x 2		12633	100/500	▲		—	
8 x 1/2	#2	12808	100/500	12808J	100/1200	—	
8 x 5/8		12810	100/500	12810J	100/1200	—	
8 x 3/4		12812	100/500	12812J	100/1200	—	
8 x 1		12816	100/500	12816J	100/1200	—	
8 x 1 1/4		12821	100/500	12821J	100/1200	—	
8 x 1 1/2		12825	100/500	▲		—	
8 x 2		12833	50/250	▲		—	
10 x 1/2	#2	13008	100/500	▲		—	
10 x 5/8		13010	100/500	▲		—	
10 x 3/4		13012	100/500	13012J	100/1200	—	
10 x 1		13016	100/500	13016J	100/1200	—	
10 x 1 1/4		13021	100/500	▲		—	
10 x 1 1/2		13025	50/250	▲		—	
10 x 2		13033	50/250	▲		—	
12 x 3/4	#3	13212	100/500	▲		—	
12 x 1		13216	100/500	▲		—	
12 x 1 1/4		13221	50/250	▲		—	
12 x 1 1/2		13225	50/250	▲		—	

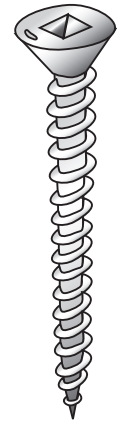

▲ Contact customer service for gravity feed jar availability.

For bulk packaging, contact customer service for quantities and availability.

## FLAT & OVAL HEAD SHEET METAL SCREWS • SQUARE DRIVE • 18-8 STAINLESS STEEL

FASTENERS • SCREWS



Flat Head		Plastic Box	
Size	Bit	Part #	Box Qty/ Std Pk
6 x 1/2	#1	72608	100/500
6 x 3/4		72612	100/500
6 x 1		72616	100/500
6 x 1 1/4		72620	100/500
8 x 1/2	#2	72808	100/500
8 x 5/8		72810	100/500
8 x 3/4		72812	100/500
8 x 1		72816	100/500
8 x 1 1/4		72820	100/500
8 x 1 1/2		72824	100/500
8 x 1 3/4		72828	100/500
8 x 2		72832	50/250
8 x 2 1/2		72840	*100
8 x 3		72848	*100
10 x 3/4	#2	73012	100/500
10 x 1		73016	100/500
10 x 1 1/4		73020	100/500
10 x 1 1/2		73024	50/250
10 x 1 3/4		73028	50/250
10 x 2		73032	50/250
10 x 2 1/2		73040	*100
10 x 3		73048	*100
12 x 1	#3	73216	100
12 x 1 1/4		73220	50/250
12 x 1 1/2		73224	50/250
12 x 1 3/4		73228	50/250
12 x 2		73232	50/250
12 x 2 1/2		73240	*100
12 x 3		73248	*100
14 x 1	#3	73416	50/250
14 x 1 1/4		73420	50/250
14 x 1 1/2		73424	50/250
14 x 2		73432	25/125
14 x 2 1/2		73440	*100
14 x 3		73448	*100

Oval Head		Plastic Box	
Size	Bit	Part #	Box Qty/ Std Pk
6 x 1/2	#1	75608	100/500
6 x 3/4		75612	100/500
6 x 1		75616	100/500
8 x 3/4	#2	75812	100/500
8 x 1		75816	100/500
8 x 1 1/4		75820	100/500
8 x 2		75832	50/250
10 x 3/4	#2	76012	100/500
10 x 1		76016	100/500
10 x 1 1/4		76020	100/500
10 x 1 1/2		76024	50/250
10 x 1 3/4		76028	50/250
10 x 2		76032	50/250
10 x 2 1/2		76040	*100
10 x 3		76048	*100

\*These items are packaged in cardboard boxes.

Harsh Environment Product

For bulk packaging, contact customer service for quantities and availability.

## HEX WASHER HEAD SHARP POINTS • SLOTTED • ZINC

		Best Merchandising Option					
		Plastic Box		Gravity Feed Jar		Job Jar	
Size	Bit Size	Part #	Box Qty/ Std Pk	Part #	Jar Qty/ Std Pk	Part #	Jar Qty
7 x 1/2	1/4"	79505	100/500	79505J	100/600	79505-6	1000
8 x 1/2	1/4"	79508	100/500	79508J	100/1200	79508-6	1000
8 x 3/4		79512	100/500	79512J	100/1200	79512-6	1000
8 x 1		79516	100/500	79516J	100/1200	79516-6	500
8 x 1 1/2		79524	100/500	79524J	100/600	79524-6	500
8 x 2		79532	50/250	79532J	100/600	79532-6	250



FASTENERS • SCREWS

## WAFER HEAD SHARP POINTS • PHILLIPS • ZINC

		Best Merchandising Option					
		Plastic Box		Gravity Feed Jar		Job Jar	
Size	Bit Size	Part #	Box Qty/ Std Pk	Part #	Jar Qty/ Std Pk	Part #	Jar Qty
8 x 1/2	#2	14809	100/500	14809J	100/1200	14809-6	1000
8 x 5/16		14811	100/500	14811J	100/1200	14811-6	1000
8 x 3/4		14813	100/500	14813J	100/1200	14813-6	1000
8 x 1		14817	100/500	14817J	100/1200	14817-6	500
8 x 1 1/4		14821	100/500	14821J	100/1200	14821-6	500



		Kits					
Part #	Description						
39558 (381 Piece Kit)	<b>#8 Wafer Head Lath Sharp Point Screw Kit</b> Includes a #2-2" Power Bit						
	<b>Sharp Point</b>						
	1/2" (80 Pieces)	5/16" (60 Pieces)	3/4" (50 Pieces)				
	<b>Tek</b>						
1/2" (80 Pieces)	5/16" (60 Pieces)	3/4" (50 Pieces)					

For bulk packaging, contact customer service for quantities and availability.

### PAN HEAD FRAMING SCREWS • PHILLIPS • SUPER SHARP • BLACK

FASTENERS • SCREWS

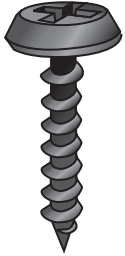

- Features sharp point metal piercing tip.
- No pre-drilling.
- Perfect for thin-gauge metal applications (up to 20 gauge).

		Best Merchandising Option					
		Plastic Box		Gravity Feed Jar		Job Jar	
Size	Bit Size	Part #	Box Qty/ Std Pk	Part #	Jar Qty/ Std Pk	Part #	Jar Qty
7 x 7/16	#2	<b>10707</b>	100/500	<b>10707J</b>	100/1200	<b>10707-6</b>	1000

### PAN HEAD FRAMING SCREWS • PHILLIPS • TEK • BLACK

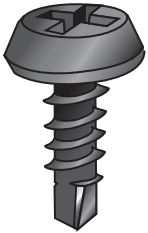

- Great for metal-to-metal applications in steel and aluminum up to 12 gauge.

		Best Merchandising Option					
		Plastic Box		Gravity Feed Jar		Job Jar	
Size	Bit Size	Part #	Box Qty/ Std Pk	Part #	Jar Qty/ Std Pk	Part #	Jar Qty
7 x 7/16	#2	<b>10708</b>	100/500	<b>10708J</b>	100/1200	<b>10708-6</b>	1000

For bulk packaging, contact customer service for quantities and availability.

## PAN HEAD TEK SCREWS • SQUARE DRIVE • ZINC

		Best Merchandising Option					
		Plastic Box	Gravity Feed Jar	Job Jar			
Size	Bit Size	Part #	Box Qty/ Std Pk	Part #	Jar Qty/ Std Pk	Part #	Jar Qty
6 x 3/8	#1	<b>26606</b>	100/500	<b>26606J</b>	100/1200	—	
8 x 1/2	#2	<b>26808</b>	100/500	<b>26808J</b>	100/1200	<b>26808-6</b>	1000
8 x 5/8		<b>26810</b>	100/500	<b>26810J</b>	100/1200	—	
8 x 3/4		<b>26812</b>	100/500	<b>26812J</b>	100/1200	<b>26812-6</b>	750
8 x 1		<b>26816</b>	100/500	<b>26816J</b>	100/1200	<b>26816-6</b>	750
8 x 1 1/4		<b>26820</b>	100/500	<b>26820J</b>	100/1200	—	
10 x 1/2	#2	<b>27008</b>	100/500	<b>27008J</b>	100/1200	<b>27008-6</b>	750
10 x 5/8		<b>27010</b>	100/500	<b>27010J</b>	100/1200	—	
10 x 3/4		<b>27012</b>	100/500	<b>27012J</b>	100/1200	<b>27012-6</b>	750
10 x 1		<b>27016</b>	100/500	<b>27016J</b>	100/1200	<b>27016-6</b>	500
10 x 1 1/4		<b>27020</b>	100/500	<b>27020J</b>	100/1200	<b>27020-6</b>	500
10 x 1 1/2		<b>27024</b>	50/250	<b>27024J</b>	100/600	<b>27024-6</b>	350
10 x 2		<b>27032</b>	50/250	<b>27032J</b>	100/600	<b>27032-6</b>	250
12 x 3/4	#3	<b>27212</b>	100/500	▲		—	
12 x 1		<b>27216</b>	100/500	<b>27216J</b>	100/1200	—	
12 x 1 1/4		<b>27220</b>	50/250	▲		—	

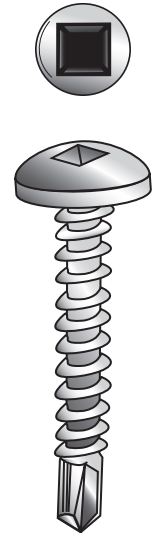

**FASTENERS • SCREWS**

Kits			
Part #	Description		
<b>39505</b>	<b>#8 &amp; #10 Pan Head Square Drive Tek Screw Kit</b> Includes a #2-2" Power Bit		
(381 Piece Kit)	8 x 1/2" (100 Pieces)	8 x 3/4" (60 Pieces)	8 x 1" (50 Pieces)
	10 x 1/2" (80 Pieces)	10 x 3/4" (50 Pieces)	10 x 1" (40 Pieces)

▲ Contact customer service for gravity feed jar availability.

For bulk packaging, contact customer service for quantities and availability.

### PAN HEAD TEK SCREWS • PHILLIPS • ZINC

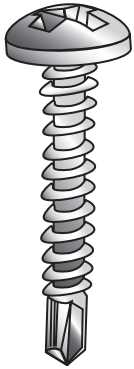

- #6 Tek Screws feature a #1 drill point.
- # 8 & #10 Tek Screws feature a #2 drill point.

		Best Merchandising Option					
		Plastic Box		Gravity Feed Jar		Job Jar	
Size	Bit Size	Part #	Box Qty/ Std Pk	Part #	Jar Qty/ Std Pk	Part #	Jar Qty
6-20 x 1/2	#1	<b>82608</b>	100/500	<b>82608J</b>	100/1200	—	—
6-20 x 5/8		<b>82610</b>	100/500	▲		—	—
6-20 x 3/4		<b>82612</b>	100/500	<b>82612J</b>	100/1200	—	—
6-20 x 1		<b>82616</b>	100/500	<b>82616J</b>	100/1200	—	—
8-18 x 1/2	#2	<b>82808</b>	100/500	<b>82808J</b>	100/1200	—	—
8-18 x 5/8		<b>82810</b>	100/500	<b>82810J</b>	100/1200	—	—
8-18 x 3/4		<b>82812</b>	100/500	<b>82812J</b>	100/1200	—	—
8-18 x 1		<b>82816</b>	100/500	<b>82816J</b>	100/1200	—	—
8-18 x 1 1/4		<b>82820</b>	100/500	<b>82820J</b>	100/1200	—	—
8-18 x 1 1/2		<b>82824</b>	100/500	<b>82824J</b>	100/1200	—	—
10-16 x 1/2	#2	<b>83008</b>	100/500	<b>83008J</b>	100/1200	—	—
10-16 x 5/8		<b>83010</b>	100/500	<b>83010J</b>	100/1200	—	—
10-16 x 3/4		<b>83012</b>	100/500	<b>83012J</b>	100/1200	<b>83012-6</b>	500
10-16 x 1		<b>83016</b>	100/500	<b>83016J</b>	100/1200	—	—
10-16 x 1 1/4		<b>83020</b>	100/500	<b>83020J</b>	100/1200	—	—
10-16 x 1 1/2		<b>83024</b>	50/250	<b>83024J</b>	100/600	—	—

Kits			
Part #	Description		
<b>39507</b>	<b>#8 &amp; #10 Pan Head Phillips Tek Screw Kit</b>		
	Includes a #2-2" Power Bit		
(381 Piece Kit)	8 x 1/2" (100 Pieces)	8 x 3/4" (60 Pieces)	8 x 1" (50 Pieces)
	10 x 1/2" (80 Pieces)	10 x 3/4" (50 Pieces)	10 x 1" (40 Pieces)

▲ Contact customer service for gravity feed jar availability.

For bulk packaging, contact customer service for quantities and availability.

## HEX WASHER HEAD TEK SCREWS • ZINC

		Best Merchandising Option					
		Plastic Box		Gravity Feed Jar		Job Jar	
Size	Bit Size	Part #	Box Qty/ Std Pk	Part #	Jar Qty/ Std Pk	Part #	Jar Qty
6-20 x 3/8	1/4"	<b>78606</b>	100/500	▲		—	
6-20 x 1/2		<b>78608</b>	100/500	▲		—	
6-20 x 5/8		<b>78610</b>	100/500	▲		—	
6-20 x 3/4		<b>78612</b>	100/500	▲		—	
6-20 x 1		<b>78616</b>	100/500	▲		—	
8-18 x 1/2	1/4"	<b>78808</b>	100/500	<b>78808J</b>	100/1200	<b>78808-6</b>	1000
8-18 x 5/8		<b>78810</b>	100/500	<b>78810J</b>	100/1200	—	
8-18 x 3/4		<b>78812</b>	100/500	<b>78812J</b>	100/1200	<b>78812-6</b>	750
8-18 x 1		<b>78816</b>	100/500	<b>78816J</b>	100/1200	<b>78816-6</b>	750
8-18 x 1 1/4		<b>78820</b>	100/500	▲		—	
8-18 x 1 1/2		<b>78824</b>	100/500	<b>78824J</b>	100/1200	—	
10-16 x 1/2	5/16"	<b>79008</b>	100/500	<b>79008J</b>	100/1200	<b>79008-6</b>	750
10-16 x 5/8		<b>79010</b>	100/500	<b>79010J</b>	100/1200	—	
10-16 x 3/4		<b>79012</b>	100/500	<b>79012J</b>	100/1200	<b>79012-6</b>	750
10-16 x 1		<b>79016</b>	100/500	<b>79016J</b>	100/1200	<b>79016-6</b>	500
10-16 x 1 1/4		<b>79020</b>	100/500	<b>79020J</b>	100/600	<b>79020-6</b>	500
10-16 x 1 1/2		<b>79024</b>	50/250	<b>79024J</b>	100/600	<b>79024-6</b>	350
10-16 x 1 3/4		<b>79028</b>	50/250	▲		—	
10-16 x 2		<b>79032</b>	50/250	<b>79032J</b>	100/600	<b>79032-6</b>	250
10-16 x 2 1/2		<b>79040</b>	*100	▲		—	
10-16 x 3		<b>79048</b>	*100	<b>79048J</b>	100/600	—	
12-14 x 3/4	5/16"	<b>79212</b>	100/500	<b>79212J</b>	100/1200	<b>79212-6</b>	500
12-14 x 1		<b>79216</b>	100/500	<b>79216J</b>	100/1200	<b>79216-6</b>	350
12-14 x 1 1/4		<b>79220</b>	50/250	<b>79220J</b>	100/600	—	
12-14 x 1 1/2		<b>79224</b>	50/250	<b>79224J</b>	100/600	—	
12-14 x 2		<b>79232</b>	50/250	<b>79232J</b>	100/600	—	
12-14 x 2 1/2		<b>79240</b>	*100	<b>79240J</b>	100/600	—	
12-14 x 3		<b>79248</b>	*100	<b>79248J</b>	100/600	—	
1/4-14 x 3/4	3/8"	<b>79412</b>	100/500	<b>79412J</b>	100/600	—	
1/4-14 x 1		<b>79416</b>	50/250	<b>79416J</b>	100/600	—	
1/4-14 x 1 1/4		<b>79420</b>	50/250	▲		—	
1/4-14 x 1 1/2		<b>79424</b>	50/250	<b>79424J</b>	100/600	—	
1/4-14 x 2		<b>79432</b>	25/125	<b>79432J</b>	100/600	—	
1/4-14 x 2 1/2		<b>79440</b>	*100	▲		—	
1/4-14 x 3		<b>79448</b>	*100	▲		—	



**FASTENERS • SCREWS**

- #6 Tek Screws feature a #1 drill point.
- #8 and #10 Tek Screws feature a #2 drill point.
- #12 and #14 Tek Screws feature a #3 drill point.

*Continued on next page.*

▲ Contact customer service for gravity feed jar availability.

\*These items are packaged in cardboard boxes.

For bulk packaging, contact customer service for quantities and availability.

## HEX WASHER HEAD TEK SCREWS • ZINC (CONT.)

Kits			
Part #	Description		
	<b>Hex Washer Head Tek Kit</b>		
<b>39509</b> (307 Piece Kit)	8 x 1/2" (100 Pieces)	8 x 3/4" (50 Pieces)	8 x 1" (40 Pieces)
	10 x 1/2" (50 Pieces)	10 x 3/4" (35 Pieces)	10 x 1" (30 Pieces)
	1/4" Mag Tek Driver	5/16" Mag Hex Driver	

## HEX WASHER HEAD TEK SCREWS • 410 STAINLESS STEEL



		Best Merchandising Option					
		Plastic Box		Gravity Feed Jar		Job Jar	
Size	Bit Size	Part #	Box Qty/ Std Pk	Part #	Jar Qty/ Std Pk	Part #	Jar Qty
6-20 x 3/8	1/4"	<b>78606SS</b>	100/500	<b>78606SSJ</b>	100/1200	—	—
6-20 x 1		<b>78616SS</b>	100/500	<b>78616SSJ</b>	100/1200	—	—
8-18 x 1/2	1/4"	<b>78808SS</b>	100/500	<b>78808SSJ</b>	100/1200	—	—
8-18 x 1		<b>78816SS</b>	100/500	<b>78816SSJ</b>	100/1200	—	—
10-16 x 1/2	5/16"	<b>79008SS</b>	100/500	<b>79008SSJ</b>	100/1200	—	—
10-16 x 1		<b>79016SS</b>	100/500	<b>79016SSJ</b>	100/1200	—	—
10-16 x 1 1/2		<b>79024SS</b>	50/250	<b>79024SSJ</b>	100/600	—	—
12-14 x 1	5/16"	<b>79216SS</b>	100/500	<b>79216SSJ</b>	100/1200	—	—
12-14 x 1 1/2		<b>79224SS</b>	50/250	<b>79224SSJ</b>	100/600	—	—

Harsh Environment Product

## WAFER HEAD LATH TEK SCREWS (K-LATH) • PHILLIPS • ZINC

• Wafer head provides a larger bearing surface.



		Best Merchandising Option					
		Plastic Box		Gravity Feed Jar		Job Jar	
Size	Bit Size	Part #	Box Qty/ Std Pk	Part #	Jar Qty/ Std Pk	Part #	Jar Qty
8 x 1/2	#2	<b>26809</b>	100/500	<b>26809J</b>	100/1200	<b>26809-6</b>	1000
8 x 5/16		<b>26811</b>	100/500	<b>26811J</b>	100/1200	<b>26811-6</b>	1000
8 x 3/4		<b>26813</b>	100/500	<b>26813J</b>	100/1200	<b>26813-6</b>	1000
8 x 1		<b>26817</b>	100/500	<b>26817J</b>	100/1200	<b>26817-6</b>	500
8 x 1 1/4		<b>26821</b>	100/500	<b>26821J</b>	100/1200	<b>26821-6</b>	500

For bulk packaging, contact customer service for quantities and availability.



## ROUND HEAD MACHINE SCREWS • PHILLIPS/SLOTTED COMBO • ZINC

		Best Merchandising Option					
		Plastic Box	Gravity Feed Jar	Job Jar			
Size	Bit Size	Part #	Box Qty/ Std Pk	Part #	Jar Qty/ Std Pk	Part #	Jar Qty
6-32 x 3/8	#2	52206	100/500	52206J	100/1200	—	—
6-32 x 1/2		52208	100/500	52208J	100/1200	52208-6	1000
6-32 x 3/4		52212	100/500	52212J	100/1200	—	—
6-32 x 1		52216	100/500	52216J	100/1200	—	—
6-32 x 1 1/4		52220	100/500	52220J	100/1200	—	—
6-32 x 1 1/2		52224	100/500	52224J	100/1200	—	—
6-32 x 2		52232	100/500	52232J	100/600	—	—
6-32 x 2 1/2		52240	*100	52240J	100/600	—	—
6-32 x 3		52248	*100	52248J	100/600	—	—
8-32 x 3/8	#2	52406	100/500	52406J	100/1200	52406-6	1000
8-32 x 1/2		52408	100/500	52408J	100/1200	52408-6	1000
8-32 x 3/4		52412	100/500	52412J	100/1200	52412-6	1000
8-32 x 1		52416	100/500	52416J	100/1200	52416-6	750
8-32 x 1 1/4		52420	100/500	52420J	100/1200	52420-6	500
8-32 x 1 1/2		52424	100/500	52424J	100/1200	52424-6	500
8-32 x 2		52432	50/250	52432J	100/600	52432-6	250
8-32 x 2 1/2		52440	*100	52440J	100/600	—	—
8-32 x 3		52448	*100	52448J	100/600	—	—
8-32 x 3 1/2 (slot only)		52356	*100	▲	—	—	—
8-32 x 4 (slot only)		52364	*100	52364J	100/600	—	—
10-24 x 3/8	#2	52606	100/500	52606J	100/1200	—	—
10-24 x 1/2		52608	100/500	52608J	100/1200	—	—
10-24 x 3/4		52612	100/500	52612J	100/1200	—	—
10-24 x 1		52616	100/500	52616J	100/1200	—	—
10-24 x 1 1/4		52620	100/500	52620J	100/1200	—	—
10-24 x 1 1/2		52624	100/500	52624J	100/600	—	—
10-24 x 2		52632	50/250	52632J	100/600	—	—
10-24 x 3		52648	*100	52648J	100/600	—	—
10-32 x 1/2	#2	52809	100/500	52809J	100/1200	52809-6	1000
10-32 x 3/4		52813	100/500	52813J	100/1200	—	—
10-32 x 1		52817	100/500	52817J	100/1200	—	—
10-32 x 1 1/4		52821	100/500	52821J	100/1200	—	—
10-32 x 1 1/2		52825	100/500	52825J	100/600	—	—
10-32 x 2		52833	50/250	52833J	100/600	—	—

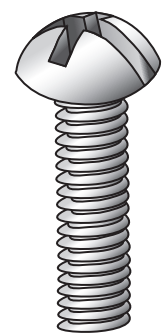

**FASTENERS • SCREWS**

▲ Contact customer service for gravity feed jar availability.

\*These items are packaged in cardboard boxes.

For bulk packaging, contact customer service for quantities and availability.

Continued on next page.

### ROUND HEAD MACHINE SCREWS • PHILLIPS/SLOTTED COMBO • ZINC (CONT.)

FASTENERS • SCREWS

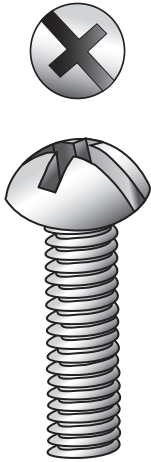

\*These items are packaged in cardboard boxes.

For bulk packaging, contact customer service for quantities and availability.

		Best Merchandising Option					
		Plastic Box		Gravity Feed Jar		Job Jar	
Size	Bit Size	Part #	Box Qty/Std Pk	Part #	Jar Qty/Std Pk	Part #	Jar Qty
¼-20 x ⅜	#3	53006	100/500	53006J	100/1200	53006-6	500
¼-20 x ½		53008	100/500	53008J	100/1200	53008-6	500
¼-20 x ¾		53012	100/500	53012J	100/1200	53012-6	500
¼-20 x 1		53016	50/250	53016J	100/600	53016-6	350
¼-20 x 1¼		53020	50/250	53020J	100/600	—	—
¼-20 x 1½		53024	50/250	53024J	100/600	—	—
¼-20 x 2		53032	25/125	53032J	100/600	—	—
¼-20 x 2½		53040	*100	53040J	100/600	—	—
¼-20 x 3		53048	*100	53048J	100/600	—	—
¼-20 x 4		53064	*100	53064J	100/600	—	—
⅜-16 x ¾	#3	53212	*100	53212J	100/600	—	—
⅜-16 x 1		53216	*100	53216J	100/600	—	—
⅜-16 x 1¼		53220	*100	53220J	100/600	—	—
⅜-16 x 1½		53224	*100	53224J	100/600	—	—
⅜-16 x 2		53232	*50	53232J	100/600	—	—
⅜-16 x 3		53248	*50	53248J	50/300	—	—
⅜-16 x 4		53264	*50	53264J	50/300	—	—

### Kits

Part #	Description		
<b>39525</b> (370 Piece Kit)	<b>6-32 Combo RH Machine Screw Kit</b>		
	6-32 x ½" (100 Pieces)	6-32 x 1" (75 Pieces)	6-32 x 1½" (40 Pieces)
	6-32 x ¾" (75 Pieces)	6-32 x 1¼" (50 Pieces)	6-32 x 2" (30 Pieces)
<b>39526</b> (310 Piece Kit)	<b>8-32 Combo RH Machine Screw Kit</b>		
	8-32 x ½" (100 Pieces)	8-32 x 1" (50 Pieces)	8-32 x 1½" (35 Pieces)
	8-32 x ¾" (60 Pieces)	8-32 x 1¼" (40 Pieces)	8-32 x 2" (25 Pieces)
<b>39538</b> (245 Piece Kit)	<b>10-24 Combo RH Machine Screw Kit</b>		
	10-24 x ½" (75 Pieces)	10-24 x 1" (40 Pieces)	10-24 x 1½" (25 Pieces)
	10-24 x ¾" (50 Pieces)	10-24 x 1¼" (30 Pieces)	10-24 x 2" (25 Pieces)
<b>39532</b> (245 Piece Kit)	<b>10-32 Combo RH Machine Screw Kit</b>		
	10-32 x ½" (75 Pieces)	10-32 x 1" (40 Pieces)	10-32 x 1½" (25 Pieces)
	10-32 x ¾" (50 Pieces)	10-32 x 1¼" (30 Pieces)	10-32 x 2" (25 Pieces)
<b>39536</b> (152 Piece Kit)	<b>¼-20 Combo RH Machine Screw Kit</b>		
	¼-20 x ⅜" (40 Pieces)	¼-20 x ¾" (30 Pieces)	¼-20 x 1½" (15 Pieces)
	¼-20 x ½" (35 Pieces)	¼-20 x 1" (20 Pieces)	¼-20 x 2" (12 Pieces)

## ROUND HEAD MACHINE SCREWS • SQUARE/SLOTTED COMBO • ZINC

		Best Merchandising Option					
		Plastic Box	Gravity Feed Jar	Job Jar			
Size	Bit Size	Part #	Box Qty/ Std Pk	Part #	Jar Qty/ Std Pk	Part #	Jar Qty
6-32 x ¼	#1	22504	100/500	▲		—	
6-32 x ⅜		22506	100/500	▲		—	
6-32 x ½		22508	100/500	▲		—	
6-32 x ¾		22512	100/500	▲		—	
6-32 x 1		22516	100/500	▲		—	
6-32 x 1¼		22520	100/500	▲		—	
6-32 x 1½		22524	100/500	▲		—	
6-32 x 2		22532	100/500	▲		—	
8-32 x ⅜	#2	22606	100/500	▲		—	
8-32 x ½		22608	100/500	▲		—	
8-32 x ⅝		22610	100/500	▲		—	
8-32 x ¾		22612	100/500	▲		—	
8-32 x 1		22616	100/500	▲		—	
8-32 x 1¼		22620	100/500	▲		—	
8-32 x 1½		22624	100/500	▲		—	
8-32 x 1¾		22628	100/500	▲		—	
8-32 x 2		22632	50/250	▲		—	
10-24 x ½	#2	22708	100/500	▲		—	
10-24 x ¾		22712	100/500	▲		—	
10-24 x 1		22716	100/500	22716J	100/1200	—	
10-24 x 1¼		22720	100/500	▲		—	
10-24 x 1½		22724	100/500	22724J	100/600	—	
10-24 x 2		22732	50/250	▲		—	
10-24 x 2½		22740	*100	▲		—	
10-24 x 3		22748	*100	22748J	100/600	—	

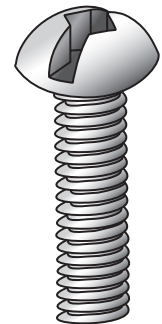

**FASTENERS • SCREWS**

Square drive is also considered tamperproof in some markets. For a selection of Stainless and Tamperproof Machine Screws see pages 46-49.

See pages 141-142 for Hex Power Bits.

*Continued on next page.*

▲ Contact customer service for gravity feed jar availability.  
\*These items are packaged in cardboard boxes.

For bulk packaging, contact customer service for quantities and availability.

## ROUND HEAD MACHINE SCREWS • SQUARE/SLOTTED COMBO • ZINC (CONT.)

FASTENERS • SCREWS

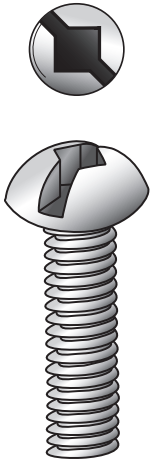

				Best Merchandising Option			
		Plastic Box		Gravity Feed Jar		Job Jar	
Size	Bit Size	Part #	Box Qty/ Std Pk	Part #	Jar Qty/ Std Pk	Part #	Jar Qty
10-32 x 1/2	#2	22808	100/500	▲			—
10-32 x 5/8		22810	100/500	▲			—
10-32 x 3/4		22812	100/500	▲			—
10-32 x 1		22816	100/500	▲			—
10-32 x 1 1/4		22820	100/500	▲			—
10-32 x 1 1/2		22824	100/500	▲			—
10-32 x 2		22832	50/250	▲			—
1/4-20 x 3/8	#3	23006	100/500	▲			—
1/4-20 x 1/2		23008	100/500	23008J	100/1200		—
1/4-20 x 3/4		23012	100/500	23012J	100/1200		—
1/4-20 x 1		23016	50/250	23016J	100/600		—
1/4-20 x 1 1/4		23020	50/250	▲			—
1/4-20 x 1 1/2		23024	50/250	23024J	100/600		—
1/4-20 x 2		23032	25/125	23032J	50/300		—
1/4-20 x 2 1/2		23040	*100	▲			—

Kits			
Part #	Description		
<b>39527</b> (310 Piece Kit)	<b>8-32 Round Head Square Drive Machine Screw Kit</b>		
	8-32 x 1/2" (100 Pieces)	8-32 x 1" (50 Pieces)	8-32 x 1 1/2" (35 Pieces)
	8-32 x 3/4" (60 Pieces)	8-32 x 1 1/4" (40 Pieces)	8-32 x 2" (25 Pieces)
<b>39534</b> (245 Piece Kit)	<b>10-32 Round Head Square Drive Machine Screw Kit</b>		
	10-32 x 1/2" (75 Pieces)	10-32 x 1" (40 Pieces)	10-32 x 1 1/2" (25 Pieces)
	10-32 x 3/4" (50 Pieces)	10-32 x 1 1/4" (30 Pieces)	10-32 x 2" (25 Pieces)
<b>39537</b> (152 Piece Kit)	<b>1/4-20 Round Head Square Drive Machine Screw Kit</b>		
	1/4-20 x 1/2" (40 Pieces)	1/4-20 1" (30 Pieces)	1/4-20 1 1/2" (15 Pieces)
	1/4-20 3/4" (35 Pieces)	1/4-20 1 1/4" (20 Pieces)	1/4-20 2" (12 Pieces)

▲ Contact customer service for gravity feed jar availability.  
\*These items are packaged in cardboard boxes.

For bulk packaging, contact customer service for quantities and availability.

## ROUND HEAD MACHINE SCREWS • SLOTTED • 18-8 STAINLESS STEEL

		Best Merchandising Option					
		Plastic Box	Gravity Feed Jar	Job Jar			
Size	Bit Size	Part #	Box Qty/ Std Pk	Part #	Jar Qty/ Std Pk	Part #	Jar Qty
8-32 x 3/8	#2	52306SS	100/500	52306SSJ	100/1200	—	—
8-32 x 1/2		52308SS	100/500	52308SSJ	100/1200	—	—
8-32 x 3/4		52312SS	100/500	52312SSJ	100/1200	—	—
8-32 x 1		52316SS	100/500	52316SSJ	100/1200	—	—
10-24 x 1	#2	52516SS	100/500	52516SSJ	100/1200	—	—
10-32 x 1		52716SS	100/500	52716SSJ	100/1200	—	—
1/4-20 x 3/8	#3	52906SS	100/500	52906SSJ	100/1200	—	—
1/4-20 x 1/2		52908SS	100/500	52908SSJ	100/1200	—	—
1/4-20 x 3/4		52912SS	100/500	52912SSJ	100/1200	—	—
1/4-20 x 1		52916SS	50/250	52916SSJ	100/600	—	—
1/4-20 x 1 1/4		52920SS	50/250	52920SSJ	100/600	—	—
1/4-20 x 1 1/2		52924SS	50/250	52924SSJ	100/600	—	—

Harsh Environment Product

For bulk packaging, contact customer service for quantities and availability.

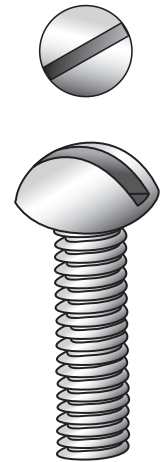

## ROUND HEAD MACHINE SCREWS • PHILLIPS • 18-8 STAINLESS STEEL

		Best Merchandising Option			
		Plastic Box	Gravity Feed Jar		
Size	Bit Size	Part #	Box Qty/ Std Pk	Part #	Jar Qty/ Std Pk
1/4-20 x 1	#3	62915SS	50/250	62915SSJ	100/600
1/4-20 x 1 1/4		62919SS	50/250	62919SSJ	100/600
1/4-20 x 1 1/2		62923SS	50/250	62923SSJ	100/600

Harsh Environment Product



## FLAT HEAD MACHINE SCREWS • SQUARE DRIVE • ZINC

FASTENERS • SCREWS



For a selection of Truss Head Machine Screws see page 37.

▲ Contact customer service for gravity feed jar availability.

\*These items are packaged in cardboard boxes.

For bulk packaging, contact customer service for quantities and availability.

				Best Merchandising Option			
		Plastic Box		Gravity Feed Jar		Job Jar	
Size	Bit Size	Part #	Box Qty/Std Pk	Part #	Jar Qty/Std Pk	Part #	Jar Qty
6-32 x ¼	#1	20504	100/500	▲		—	
6-32 x ½		20508	100/500	▲		—	
6-32 x ¾		20512	100/500	▲		—	
6-32 x 1		20516	100/500	20516J	100/1200	—	
6-32 x 1¼		20520	100/500	20520J	100/1200	—	
6-32 x 1½		20524	100/500	20524J	100/1200	—	
6-32 x 2		20532	100/500	20532J	100/1200	—	
8-32 x ½	#2	20608	100/500	▲		—	
8-32 x ¾		20612	100/500	▲		—	
8-32 x 1		20616	100/500	▲		—	
8-32 x 1¼		20620	100/500	▲		—	
8-32 x 1½		20624	100/500	▲		—	
8-32 x 2		20632	50/250	▲		—	
10-24 x ½	#2	20708	100/500	▲		—	
10-24 x ¾		20712	100/500	▲		—	
10-24 x 1		20716	100/500	▲		—	
10-24 x 1¼		20720	100/500	▲		—	
10-24 x 1½		20724	100/500	20724J	100/600	—	
10-24 x 2		20732	50/250	20732J	50/300	—	
10-24 x 2½		20740	*100	▲		—	
10-24 x 3		20748	*100	▲		—	
10-32 x ½	#2	20808	100/500	▲		—	
10-32 x ¾		20812	100/500	▲		—	
10-32 x 1		20816	100/500	▲		—	
10-32 x 1¼		20820	100/500	▲		—	
¼-20 x ½	#3	21008	100/500	▲		—	
¼-20 x ¾		21012	100/500	▲		—	
¼-20 x 1		21016	50/250	▲		—	
¼-20 x 1¼		21020	50/250	▲		—	
¼-20 x 1½		21024	50/250	▲		—	
¼-20 x 2		21032	25/125	▲		—	
¼-20 x 2½		21040	*100	▲		—	
¼-20 x 3		21048	*100	▲		—	

## FLAT HEAD MACHINE SCREWS • SLOTTED • ZINC

		Best Merchandising Option					
		Plastic Box	Gravity Feed Jar	Job Jar			
Size	Bit Size	Part #	Box Qty/ Std Pk	Part #	Jar Qty/ Std Pk	Part #	Jar Qty
6-32 x 1/2	#6-#8	50108	100/500	50108J	100/1200	—	—
6-32 x 3/4		50112	100/500	50112J	100/1200	—	—
6-32 x 1		50116	100/500	50116J	100/1200	—	—
6-32 x 1 1/4		50120	100/500	50120J	100/1200	—	—
6-32 x 1 1/2		50124	100/500	50124J	100/1200	—	—
6-32 x 1 3/4		50128	100/500	▲	—	—	—
6-32 x 2		50132	100/500	50132J	100/600	—	—
6-32 x 2 1/2		50140	*100	50140J	100/600	—	—
6-32 x 3		50148	*100	50148J	100/600	—	—
6-32 x 4		50164	*100	▲	—	—	—
8-32 x 3/8	#8-#10	50306	100/500	▲	—	—	—
8-32 x 1/2		50308	100/500	50308J	100/1200	—	—
8-32 x 3/4		50312	100/500	50312J	100/1200	—	—
8-32 x 1		50316	100/500	50316J	100/1200	—	—
8-32 x 1 1/4		50320	100/500	50320J	100/1200	—	—
8-32 x 1 1/2		50324	100/500	50324J	100/1200	—	—
8-32 x 2		50332	50/250	50332J	100/600	—	—
8-32 x 2 1/2		50340	*100	50340J	100/600	—	—
8-32 x 3		50348	*100	50348J	100/600	—	—
10-24 x 1/2	#10-#12	50508	100/500	▲	—	—	—
10-24 x 3/4		50512	100/500	▲	—	—	—
10-24 x 1		50516	100/500	▲	—	—	—
10-24 x 1 1/4		50520	100/500	▲	—	—	—
10-24 x 1 1/2		50524	100/500	▲	—	—	—
10-24 x 2		50532	50/250	▲	—	—	—
10-24 x 2 1/2		50540	*100	▲	—	—	—
10-24 x 3		50548	*100	▲	—	—	—
10-32 x 1/2	#10-#12	50708	100/500	▲	—	—	—
10-32 x 3/4		50712	100/500	▲	—	—	—
10-32 x 1		50716	100/500	50716J	100/1200	—	—
10-32 x 1 1/4		50720	100/500	▲	—	—	—
10-32 x 1 1/2		50724	100/500	▲	—	—	—
10-32 x 2		50732	50/250	▲	—	—	—
10-32 x 2 1/2		50740	*100	▲	—	—	—
10-32 x 3		50748	*100	▲	—	—	—
1/4-20 x 1/2	#12-#14	50908	100/500	▲	—	—	—
1/4-20 x 3/4		50912	100/500	▲	—	—	—
1/4-20 x 1		50916	50/250	50916J	100/600	—	—
1/4-20 x 1 1/4		50920	50/250	50920J	100/600	—	—
1/4-20 x 1 1/2		50924	50/250	50924J	100/600	—	—
1/4-20 x 2		50932	25/125	▲	—	—	—
1/4-20 x 2 1/2		50940	*100	▲	—	—	—
1/4-20 x 3		50948	*100	50948J	100/600	—	—



▲ Contact customer service for gravity feed jar availability.

\*These items are packaged in cardboard boxes.

For bulk packaging, contact customer service for quantities and availability.

## FLAT HEAD MACHINE SCREWS • SLOTTED • ZINC (CONT.)

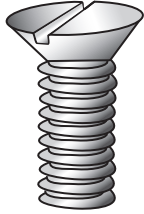

Kits			
Part #	Description		
<b>39541</b> (415 Piece Kit)	<b>6-32 Flat Head Slot Machine Screw Kit</b>		
	6-32 x 1/2" (100 Pieces)	6-32 x 1" (75 Pieces)	6-32 x 1 1/2" (45 Pieces)
	6-32 x 3/4" (100 Pieces)	6-32 x 1 1/4" (55 Pieces)	6-32 x 2" (40 Pieces)

## FLAT HEAD MACHINE SCREWS • SLOTTED • 18-8 STAINLESS STEEL

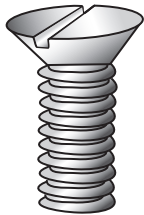

		Best Merchandising Option					
		Plastic Box	Gravity Feed Jar	Job Jar			
Size	Bit Size	Part #	Box Qty/ Std Pk	Part #	Jar Qty/ Std Pk	Part #	Jar Qty
6-32 x 3/4	18-8	<b>60112SS</b>	100/500	<b>60112SSJ</b>	100/1200	—	—
6-32 x 1		<b>60116SS</b>	100/500	<b>60116SSJ</b>	100/1200	—	—
6-32 x 1 1/2		<b>60124SS</b>	100/500	<b>60124SSJ</b>	100/1200	—	—
6-32 x 2		<b>60132SS</b>	100/500	<b>60132SSJ</b>	100/600	—	—

Harsh Environment Product

## FLAT HEAD MACHINE SCREWS • PHILLIPS • ZINC



		Best Merchandising Option					
		Plastic Box	Gravity Feed Jar	Job Jar			
Size	Bit Size	Part #	Box Qty/ Std Pk	Part #	Jar Qty/ Std Pk	Part #	Jar Qty
6-32 x 1/2	#1	<b>50109</b>	100/500	<b>50109J</b>	100/1200	—	—
6-32 x 3/4		<b>50113</b>	100/500	<b>50113J</b>	100/1200	—	—
6-32 x 1		<b>50117</b>	100/500	<b>50117J</b>	100/1200	—	—
6-32 x 1 1/4		<b>50121</b>	100/500	<b>50121J</b>	100/1200	—	—
6-32 x 1 1/2		<b>50125</b>	100/500	<b>50125J</b>	100/1200	—	—
6-32 x 2		<b>50133</b>	100/500	<b>50133J</b>	100/600	—	—
6-32 x 2 1/2		<b>50141</b>	*100	<b>50141J</b>	100/600	—	—
6-32 x 3		<b>50149</b>	*100	<b>50149J</b>	100/600	—	—
8-32 x 1 1/2		<b>50325</b>	100/500	▲		—	—

▲ Contact customer service for gravity feed jar availability.  
\*These items are packaged in cardboard boxes.

For bulk packaging, contact customer service for quantities and availability.



## TRUSS HEAD MACHINE SCREWS • PHILLIPS/SLOTTED • ZINC

• Designed for use with receptacles.

		Best Merchandising Option					
		Plastic Box		Gravity Feed Jar		Job Jar	
Size	Bit Size	Part #	Box Qty/ Std Pk	Part #	Jar Qty/ Std Pk	Part #	Jar Qty
6-32 x ½	#2	52008	100/500	52008J	100/1200	—	—
6-32 x ¾		52012	100/500	52012J	100/1200	—	—
6-32 x 1		52016	100/500	52016J	100/1200	52016-6	750
6-32 x 1¼		52020	100/500	52020J	100/1200	—	—
6-32 x 1½		52024	100/500	52024J	100/1200	52024-6	500
6-32 x 2		52032	100/500	52032J	100/600	52032-6	350
6-32 x 3		52048	*100	▲		—	—
6-32 x 4		52064	*100	▲		—	—
10-24 x 2	#2	52133	*100	▲		—	—
10-24 x 3		52149	*100	▲		—	—
10-24 x 4		52165	*100	▲		—	—
¼-20 x 3	#3	52249	*100	▲		—	—
¼-20 x 4		52265	*100	▲		—	—

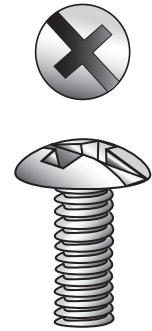

FASTENERS • SCREWS



Part #	Description		
39546 (380 Piece Kit)	6-32 Truss Head Machine Screw Combo Kit		
	½" (100 Pieces)	1" (65 Pieces)	1½" (40 Pieces)
	¾" (90 Pieces)	1¼" (50 Pieces)	2" (35 Pieces)

## TRUSS HEAD MACHINE SCREWS • SQUARE/SLOTTED • ZINC

		Best Merchandising Option					
		Plastic Box		Gravity Feed Jar		Job Jar	
Size	Bit Size	Part #	Box Qty	Part #	Jar Qty/ Std Pk	Part #	Jar Qty
6-32 x 2	#1	24433	100	▲		—	—
6-32 x 3		24449 ★	*100	▲		—	—
6-32 x 4		24465 ★	*100	▲		—	—
8-32 x ½	#2	24608	100/500	▲		—	—
10-24 x 2	#2	24733	100	▲		—	—
10-24 x 3		24749	*100	▲		—	—
10-24 x 4		24765	*100	▲		—	—
¼-20 x 3	#3	25049	*100	▲		—	—
¼-20 x 4		25065	*100	▲		—	—

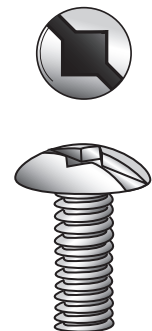

▲ Contact customer service for gravity feed jar availability.

\*These items are packaged in cardboard boxes.

★ Made in USA

For bulk packaging, contact customer service for quantities and availability.

### WALL PLATE SCREWS • SLOTTED • 6-32 OVAL HEAD

FASTENERS • SCREWS



▲ Contact customer service for gravity feed jar availability.

🛡️ Harsh Environment Product

For bulk packaging, contact customer service for quantities and availability.

		Best Merchandising Option					
		📦 Plastic Box		📦 Gravity Feed Jar		📦 Job Jar	
Length	Color	Part #	Box Qty/Std Pk	Part #	Jar Qty/Std Pk	Part #	Jar Qty
5/16	White	51104	100/500	51104J	100/1200	—	—
1/2	White	51109	100/500	51109J	100/1200	—	—
3/4	White	51113	100/500	51113J	100/1200	—	—
1	White	51117	100/500	51117J	100/1200	—	—
5/16	Ivory	51105	100/500	51105J	100/1200	—	—
1/2	Ivory	51108	100/500	51108J	100/1200	—	—
3/4	Ivory	51112	100/500	51112J	100/1200	—	—
1	Ivory	51116	100/500	51116J	100/1200	—	—
5/16	Lt. Almd	51103	100/500	51103J	100/1200	—	—
1/2	Lt. Almd	51107	100/500	51107J	100/1200	—	—
3/4	Lt. Almd	51111	100/500	▲	▲	—	—
1	Lt. Almd	51115	100/500	▲	▲	—	—
1/2	Brown	51110	100/500	51110J	100/1200	—	—
3/4	Brown	51114	100/500	▲	▲	—	—
1	Brown	51118	100/500	▲	▲	—	—
1/2	Stainless	53608 🛡️	100/500	53608J 🛡️	100/1200	—	—
3/4	Stainless	53612 🛡️	100/500	▲	▲	—	—
1	Stainless	53616 🛡️	100/500	▲	▲	—	—
1/2	Nyln Ivry	53708	100/500	▲	▲	—	—
3/4	Nyln Ivry	53712	100/500	▲	▲	—	—
1	Nyln Ivry	53716	100/500	53716J	100/1200	—	—
1/2	Nyln Wht	53808	100/500	▲	▲	—	—
3/4	Nyln Wht	53812	100/500	▲	▲	—	—
1	Nyln Wht	53816	100/500	53816J	100/1200	—	—



Kits

Part #	Description		
<b>39515</b> (600 Piece Kit)	<b>White &amp; Ivory Wall Plate Screw Kit</b>		
	5/16" White (100 Pieces)	1/2" White (100 Pieces)	3/4" White (100 Pieces)
	5/16" Ivory (100 Pieces)	1/2" Ivory (100 Pieces)	3/4" Ivory (100 Pieces)
<b>39514</b> (300 Piece Kit)	<b>Light Almond Wall Plate Screw Kit</b>		
	5/16" Lt. Almond (75 Pieces)	3/4" Lt. Almond (75 Pieces)	
	1/2" Lt. Almond (75 Pieces)	1" Lt. Almond (75 Pieces)	
<b>39508</b> (300 Piece Kit)	<b>Residential Wall Plate Screw Kit</b>		
	<b>1/2" Wall Plate</b>		
	White (50 Pieces)	Ivory (50 Pieces)	Light Almond (50 Pieces)
	<b>5/16" Decora</b>		
	White (50 Pieces)	Ivory (50 Pieces)	Light Almond (50 Pieces)

All kits are standard packed 5 units per sleeve.

## FLAT HEAD WOOD SCREWS • SQUARE DRIVE • ZINC

		Best Merchandising Option					
		Plastic Box	Gravity Feed Jar	Job Jar			
Size	Bit Size	Part #	Box Qty/ Std Pk	Part #	Jar Qty/ Std Pk	Part #	Jar Qty
4 x 3/8**	#0	12406	100/500	▲		—	
4 x 1/2**		12408	100/500	▲		—	
4 x 3/4**		12412	100/500	12412J	100/1200	—	
4 x 1**		12416	100/500	12416J	100/1200	—	
5 x 3/4**	#1	12512	100/500	▲		—	
6 x 1/2**	#1	12608	100/500	▲		—	
6 x 5/8**		12610	100/500	▲		—	
6 x 3/4**		12612	100/500	12612J	100/1200	—	
6 x 1**		12616	100/500	12616J	100/1200	—	
6 x 1 1/4		12620	100/500	▲		—	
6 x 1 1/2		12624	100/500	▲		—	
6 x 1 3/4		12628	100/500	▲		—	
6 x 2		12632	100/500	▲		—	
8 x 1/2**	#2	12808	100/500	12808J	100/1200	—	
8 x 5/8**		12810	100/500	12810J	100/1200	—	
8 x 3/4**		12812	100/500	12812J	100/1200	—	
8 x 1**		12816	100/500	12816J	100/1200	—	
8 x 1 1/4		12820	100/500	▲		—	
8 x 1 1/2		12824	100/500	12824J	100/1200	—	
8 x 1 3/4		12828	100/500	▲		—	
8 x 2		12832	50/250	12832J	50/600	—	
8 x 2 1/2		12840	*100	▲		—	
8 x 3		12848	*100	▲		—	
8 x 3 1/2		12856	*100	▲		—	
8 x 4		12864	*100	▲		—	
10 x 1/2**	#2	13008	100/500	▲		—	
10 x 3/4**		13012	100/500	13012J	100/1200	—	
10 x 1**		13016	100/500	13016J	100/1200	—	
10 x 1 1/4	#2	13020	100/500	13020J	100/1200	—	
10 x 1 1/2		13024	50/250	13024J	100/600	—	
10 x 1 3/4		13028	50/250	▲		—	
10 x 2		13032	50/250	13032J	100/600	—	
10 x 2 1/4		13036	*100	▲		—	
10 x 2 1/2		13040	*100	▲		—	
10 x 3		13048	*100	▲		—	

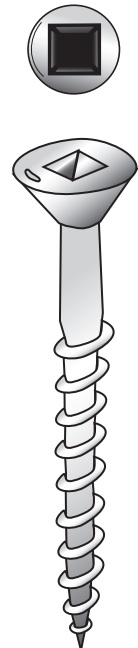

▲ Contact customer service for gravity feed jar availability.

\*These items are packaged in cardboard boxes.

\*\*These sizes are fully threaded.

For bulk packaging, contact customer service for quantities and availability.

Continued on next page.

### FLAT HEAD WOOD SCREWS • SQUARE DRIVE • ZINC (CONT.)

FASTENERS • SCREWS

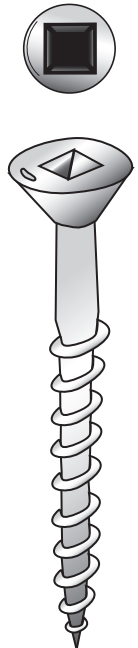

		Best Merchandising Option					
		Plastic Box		Gravity Feed Jar		Job Jar	
Size	Bit Size	Part #	Box Qty/ Std Pk	Part #	Jar Qty/ Std Pk	Part #	Jar Qty
10 x 3½		<b>13056</b>	*100	▲		—	
10 x 4		<b>13064</b>	*100	▲		—	
12 x ¾**	#3	<b>13212</b>	100/500	▲		—	
12 x 1**		<b>13216</b>	100/500	▲		—	
12 x 1¼		<b>13220</b>	50/250	▲		—	
12 x 1½		<b>13224</b>	50/250	▲		—	
12 x 2		<b>13232</b>	50/250	▲		—	
12 x 2½		<b>13240</b>	*100	▲		—	
12 x 3		<b>13248</b>	*100	▲		—	
12 x 3½		<b>13256</b>	*100	▲		—	
12 x 4		<b>13264</b>	*100	▲		—	
14 x ¾**	#3	<b>13412</b>	100/500	▲		—	
14 x 1**		<b>13416</b>	50/250	▲		—	
14 x 1¼		<b>13420</b>	50/250	▲		—	
14 x 1½		<b>13424</b>	50/250	▲		—	
14 x 2		<b>13432</b>	25/125	▲		—	
14 x 2½		<b>13440</b>	*100	▲		—	
14 x 3		<b>13448</b>	*100	▲		—	
14 x 3½		<b>13456</b>	*100	▲		—	
14 x 4		<b>13464</b>	*100	▲		—	

Kits				
Part #	Description			
<b>39554</b> (316 Piece Kit)	<b>#8 Flat Head Wood Screw Kit</b> Includes a #2-2" Power Bit			
	8 x ½" (100 Pieces)	8 x 1" (50 Pieces)	8 x 1½" (35 Pieces)	
	8 x ¾" (60 Pieces)	8 x 1¼" (40 Pieces)	8 x 2" (30 Pieces)	
<b>39555</b> (231 Piece Kit)	<b>#10 Flat Head Wood Screw Kit</b> Includes a #2-2" Power Bit			
	10 x ½" (70 Pieces)	10 x 1" (35 Pieces)	10 x 1½" (25 Pieces)	
	10 x ¾" (50 Pieces)	10 x 1¼" (30 Pieces)	10 x 2" (20 Pieces)	

▲ Contact customer service for gravity feed jar availability.  
 \*These items are packaged in cardboard boxes.  
 \*\*These sizes are fully threaded.

For bulk packaging, contact customer service for quantities and availability.

## TRIM HEAD WOOD SCREWS • SQUARE DRIVE • BLACK FINISH

		Best Merchandising Option							
		Plastic Box	Gravity Feed Jar	Job Jar	1lb Boxes				
Size	Bit Size	Part #	Box Qty/ Std Pk	Part #	Jar Qty/ Std Pk	Part #	Jar Qty	Part #	Box Qty
6 x 1	#1	<b>13716</b>	100/500	▲		—		<b>137161lb</b>	418
6 x 1½		<b>13726</b>	100/500	▲		—		<b>137261lb</b>	242
6 x 2¼		<b>13736</b>	*100	▲		—		<b>137361lb</b>	187
8 x 3	#2	<b>13748</b>	*100	▲		—		<b>137481lb</b>	97

Quantities for 1lb boxes are approximate.



## TRIM HEAD WOOD SCREWS • SQUARE DRIVE • STAINLESS STEEL

		Best Merchandising Option					
		Cardboard Box	Gravity Feed Jar	Job Jar			
Size	Bit Size	Part #	Box Qty/ Std Pk	Part #	Jar Qty/ Std Pk	Part #	Jar Qty
7 x 1½	#1	<b>72726</b> ♡	100/500	▲		—	
7 x 2¼		<b>72736</b> ♡	100/500	▲		—	
7 x 3		<b>72748</b> ♡	100/500	▲		—	

♡ Harsh Environment Product

## DEEP THREAD FLAT HEAD PARTICLE BOARD SCREWS • SQUARE DRIVE • ZINC

Deep thread particle board screws are characterized by wider-spaced threads set deeper than a typical wood screw.

- #8 and #10 particle board screws require a #2 square drive bit.

		Best Merchandising Option					
		Plastic Box	Gravity Feed Jar	Job Jar			
Size	Bit Size	Part #	Box Qty/ Std Pk	Part #	Jar Qty/ Std Pk	Part #	Jar Qty
8 x ¾	#2	<b>13814</b>	100/500	▲		—	
8 x 1		<b>13815</b>	50/250	▲		—	
8 x 1¼		<b>13822</b>	50/250	▲		—	
8 x 1½		<b>13826</b>	50/250	▲		—	
8 x 1¾		<b>13830</b>	*100	▲		—	
8 x 2		<b>13834</b>	*100	▲		—	
8 x 2¼		<b>13838</b>	*100	▲		—	
8 x 2½		<b>13842</b>	*100	<b>13842J</b>	100/600	—	
8 x 3		<b>13850</b>	*100	▲		—	
10 x 1¼	#2	<b>14022</b>	100/500	▲		—	
10 x 1½		<b>14026</b>	50/250	▲		—	
10 x 1¾		<b>14030</b>	50/250	▲		—	
10 x 2¼		<b>14038</b>	*100	▲		—	

Continued on next page.

▲ Contact customer service for gravity feed jar availability.  
\*These items are packaged in cardboard boxes.

For bulk packaging, contact customer service for quantities and availability.

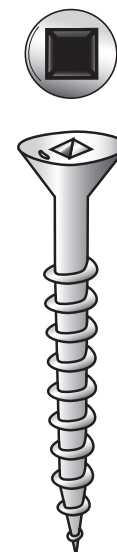

## DEEP THREAD FLAT HEAD PARTICLE BOARD SCREWS • SQUARE DRIVE • ZINC (CONT.)

FASTENERS • SCREWS

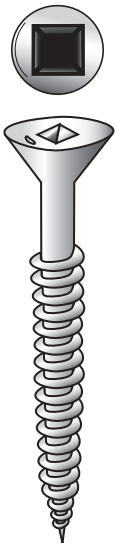

Kits			
Part #	Description		
<b>39548</b> (241 Piece Kit)	<b>#8 Deep Thread Particle Board Screw Kit</b> Includes a #2-2" Power Bit		
	8 x 1/2" (60 Pieces)	8 x 1 1/4" (40 Pieces)	8 x 1 3/4" (30 Pieces)
	8 x 1" (50 Pieces)	8 x 1 1/2" (30 Pieces)	8 x 2" (30 Pieces)

▲ Contact customer service for gravity feed jar availability.  
\*These items are packaged in cardboard boxes.

For bulk packaging, contact customer service for quantities and availability.

## DEEP THREAD FLAT HEAD PARTICLE BOARD SCREWS • SQUARE DRIVE • BLACK

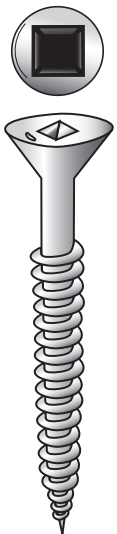

		Best Merchandising Option					
		Plastic Box		Gravity Feed Jar		Job Jar	
Size	Bit Size	Part #	Box Qty/ Std Pk	Part #	Jar Qty/ Std Pk	Part #	Jar Qty
6 x 1	#1	<b>13616</b>	100/500	▲			—
6 x 1 1/2		<b>13624</b>	100/500	▲			—
6 x 2		<b>13632</b>	100/500	▲			—
8 x 3/4	#2	<b>13812</b>	100/500	<b>13812J</b>	100/1200		—
8 x 1		<b>13816</b>	100/500	▲			—
8 x 1 1/4		<b>13820</b>	100/500	<b>13820J</b>	100/1200		—
8 x 1 1/2		<b>13824</b>	100/500	<b>13824J</b>	100/1200		—
8 x 1 3/4		<b>13828</b>	100/500	▲			—
8 x 2		<b>13832</b>	50/250	<b>13832J</b>	50/600		—
8 x 2 1/4		<b>13836</b>	*100	▲			—
8 x 2 1/2		<b>13840</b>	*100	<b>13840J</b>	100/600		—
8 x 3		<b>13848</b>	*100	▲			—
10 x 1	#2	<b>14016</b>	100/500	▲			—
10 x 1 1/4		<b>14020</b>	100/500	▲			—
10 x 1 1/2		<b>14024</b>	50/250	▲			—
10 x 1 3/4		<b>14028</b>	50/250	▲			—
10 x 2		<b>14032</b>	50/250	▲			—
10 x 2 1/4		<b>14036</b>	*100	▲			—
10 x 2 1/2		<b>14040</b>	*100	▲			—
10 x 3		<b>14048</b>	*100	▲			—

▲ Contact customer service for gravity feed jar availability.

\*These items are packaged in cardboard boxes.

For bulk packaging, contact customer service for quantities and availability.

## FINE THREAD BUGLE HEAD DRYWALL SCREWS • PHILLIPS • BLACK

- Symmetrical thread.
- Ideal for metal stud applications up to 20 gauge.
- Available in case quantities. Call for details.

		Best Merchandising Option					
		Plastic Box	Gravity Feed Jar	Job Jar			
Size	Bit Size	Part #	Box Qty/ Std Pk	Part #	Jar Qty/ Std Pk	Part #	Jar Qty
6 x 1	#2	<b>79616</b>	100/500	<b>79616J</b>	100/1200	—	—
6 x 1½		<b>79618</b>	100/500	<b>79618J</b>	100/1200	—	—
6 x 1¼		<b>79624</b>	100/500	<b>79624J</b>	100/1200	<b>79624-6</b>	500
6 x 1⅝		<b>79626</b>	100/500	<b>79626J</b>	100/1200	<b>79626-6</b>	500
6 x 2		<b>79632</b>	50/250	<b>79632J</b>	100/600	<b>79632-6</b>	350
6 x 2¼		<b>79636</b>	*100	<b>79636J</b>	100/600	—	—
8 x 2½	#2	<b>79840</b>	*100	<b>79840J</b>	100/600	—	—
8 x 3		<b>79848</b>	*100	<b>79848J</b>	100/600	—	—
10 x 4	#2	<b>79964</b>	*100	▲		—	—
10 x 4½		<b>79972</b>	*100	▲		—	—
10 x 5		<b>79980</b>	*100	▲		—	—

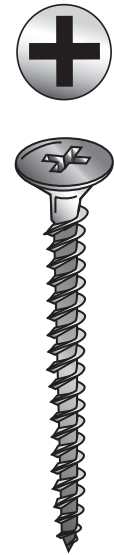

FASTENERS • SCREWS

## FINE THREAD BUGLE HEAD DRYWALL TEK SCREWS • PHILLIPS • BLACK

- #6 Tek has a #1 point.
- #8 Tek has a #2 point.
- Ideal for metal studs up to 12 gauge.

		Best Merchandising Option					
		Plastic Box	Gravity Feed Jar	Job Jar			
Size	Bit Size	Part #	Box Qty/ Std Pk	Part #	Jar Qty/ Std Pk	Part #	Jar Qty
6 x 1¼	#2	<b>79623</b>	100/500	<b>79623J</b>	100/1200	—	—
6 x 1⅝		<b>79627</b>	100/500	<b>79627J</b>	100/1200	—	—
6 x 1⅞		<b>79630</b>	100/500	<b>79630J</b>	100/1200	—	—
8 x 2⅝	#2	<b>79845</b>	*100	▲		—	—
8 x 3		<b>79850</b>	*100	▲		—	—



▲ Contact customer service for gravity feed jar availability.  
\*These items are packaged in cardboard boxes.

For bulk packaging, contact customer service for quantities and availability.

## COARSE THREAD BUGLE HEAD DRYWALL SCREWS • PHILLIPS • BLACK

FASTENERS • SCREWS

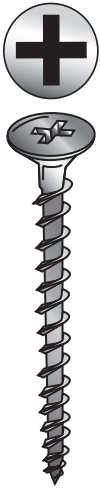

		Best Merchandising Option					
		Plastic Box		Gravity Feed Jar		Job Jar	
Size	Bit Size	Part #	Box Qty/ Std Pk	Part #	Jar Qty/ Std Pk	Part #	Jar Qty
6 x 1	#2	<b>79617</b>	100/500	<b>79617J</b>	100/1200	—	—
6 x 1½		<b>79619</b>	100/500	<b>79619J</b>	100/1200	—	—
6 x 1¼		<b>79625</b>	100/500	<b>79625J</b>	100/1200	<b>79625-6</b>	500
6 x 1½		<b>79628</b>	100/500	<b>79628J</b>	100/1200	<b>79628-6</b>	500
6 x 2		<b>79634</b>	50/250	<b>79634J</b>	100/600	<b>79634-6</b>	350
8 x 2½	#2	<b>79841</b>	*100	<b>79841J</b>	100/600	—	—
8 x 3		<b>79849</b>	*100	<b>79849J</b>	100/600	—	—

For bulk packaging, contact customer service for quantities and availability.

Kits			
Part #	Description		
<b>39564</b>	<b>Black Coarse Drywall Screw Kit</b> Includes a #2-2" Power Bit		
(221 Piece Kit)	6 x 1¼" (100 Pieces)	6 x 1½" (70 Pieces)	6 x 2" (50 Pieces)

▲ Contact customer service for gravity feed jar availability. \*These items are packaged in cardboard boxes.

## COARSE THREAD BUGLE HEAD DRYWALL SCREWS • PHILLIPS • YELLOW ZINC

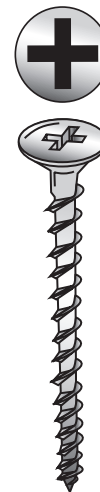

		Best Merchandising Option					
		Plastic Box		Gravity Feed Jar		Job Jar	
Size	Bit Size	Part #	Box Qty/ Std Pk	Part #	Jar Qty/ Std Pk	Part #	Jar Qty
6 x 1	#2	<b>79620</b>	100/500	<b>79620J</b>	100/1200	<b>79620-6</b>	500
6 x 1¼		<b>79622</b>	100/500	<b>79622J</b>	100/1200	<b>79622-6</b>	500
6 x 1½		<b>79629</b>	100/500	<b>79629J</b>	100/1200	<b>79629-6</b>	500
6 x 2		<b>79635</b>	50/250	<b>79635J</b>	100/600	<b>79635-6</b>	350
6 x 2¼		<b>79637</b>	*100	<b>79637J</b>	100/600	<b>79637-6</b>	250
8 x 2½	#2	<b>79843</b>	*100	<b>79843J</b>	100/600	<b>79843-6</b>	250
8 x 3		<b>79851</b>	*100	<b>79851J</b>	100/600	<b>79851-6</b>	150
10 x 4	#2	<b>79965</b>	*100	▲		—	
10 x 5		<b>79981</b>	*100	▲		—	
10 x 6		<b>79997</b>	*100	▲		—	

For bulk packaging, contact customer service for quantities and availability.

Kits			
Part #	Description		
<b>39563</b>	<b>Yellow Zinc Drywall Screw Kit</b> Includes a #2-2" Power Bit		
(221 Piece Kit)	6 x 1¼" (100 Pieces)	6 x 1½" (70 Pieces)	6 x 2" (50 Pieces)

▲ Contact customer service for gravity feed jar availability. \*These items are packaged in cardboard boxes.



## WOODEX® ALL-WEATHER DECK SCREWS • SQUARE DRIVE

- Wood chip cutting point.
- Corrosion resistant.
- Mechanical galvanized.
- Includes a #2-2 square drive power bit.

		1lb Boxes		5lb Boxes		Job Jar	
Size	Bit Size	Part #	Box Qty/ Std Pk	Part #	Box Qty/ Std Pk	Part #	Jar Qty
7 x 1¼	#2	<b>180201lb</b>	246	<b>180205lb</b>	1230	<b>18020-6</b>	750
8 x 1⅜	#2	<b>180221lb</b>	180	<b>180225lb</b>	900	<b>18022-6</b>	500
8 x 1⅝		<b>180261lb</b>	161	<b>180265lb</b>	805	<b>18026-6</b>	500
9 x 2	#2	<b>181321lb</b>	110	<b>181325lb</b>	550	<b>18132-6</b>	250
9 x 2½		<b>181401lb</b>	94	<b>181405lb</b>	470	<b>18140-6</b>	200
9 x 3		<b>181481lb</b>	76	<b>181485lb</b>	380	<b>18148-6</b>	150
10 x 4	#2	<b>182641lb</b>	50	<b>182645lb</b>	250	<b>18264-6</b>	100
10 x 5		<b>182801lb</b>	40	<b>182805lb</b>	200	—	
10 x 6		<b>182961lb</b>	33	<b>182965lb</b>	165	—	

Quantities for 1lb and 5lb boxes are approximate.

Harsh Environment Product

For bulk packaging, contact customer service for quantities and availability.

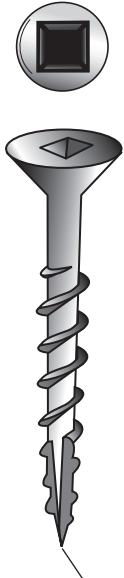

Type 17 Point

## PAN, FLAT & OVAL HEAD SPANNER HEAD SHEET METAL SCREWS • STAINLESS STEEL

FASTENERS • SCREWS

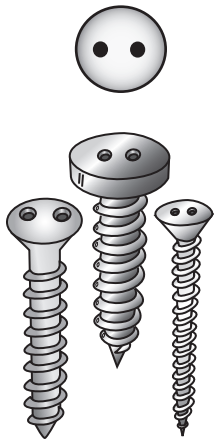

• Tamperproof screws are available by special order only, are subject to minimum order requirements and are non-returnable. Please allow an extra 5–7 days shipping.

		Cardboard Box			
Size	Insert Driver	Pan Head Spanner	Flat Head Spanner	Oval Head Spanner	Box Qty
6 x 3/8	#6 Spanner	10606TP ★ ♡	12606TP ★ ♡	—	100
6 x 1/2		10608TP ★ ♡	12608TP ★ ♡	14608TP ★ ♡	100
6 x 5/8		10610TP ★ ♡	12610TP ★ ♡	—	100
6 x 3/4		10612TP ★ ♡	12612TP ★ ♡	14612TP ★ ♡	100
6 x 1		10616TP ★ ♡	12616TP ★ ♡	14616TP ★ ♡	100
6 x 1 1/4		10620TP ★ ♡	12620TP ★ ♡	14620TP ★ ♡	100
6 x 1 1/2		10624TP ★ ♡	12624TP ★ ♡	14624TP ★ ♡	100
6 x 2		10632TP ★ ♡	12632TP ★ ♡	—	100
8 x 3/8	#8 Spanner	10806TP ★ ♡	12806TP ★ ♡	—	100
8 x 1/2		10808TP ★ ♡	12808TP ★ ♡	14808TP ★ ♡	100
8 x 3/4		10812TP ★ ♡	12812TP ★ ♡	14812TP ★ ♡	100
8 x 1		10816TP ★ ♡	12816TP ★ ♡	14816TP ★ ♡	100
8 x 1 1/4		10820TP ★ ♡	12820TP ★ ♡	14820TP ★ ♡	100
8 x 1 1/2		10824TP ★ ♡	12824TP ★ ♡	14824TP ★ ♡	100
8 x 2		10832TP ★ ♡	12832TP ★ ♡	—	100
10 x 1/2	#10 Spanner	11008TP ★ ♡	13008TP ★ ♡	15008TP ★ ♡	100
10 x 5/8		11010TP ★ ♡	13010TP ★ ♡	15010TP ★ ♡	100
10 x 3/4		11012TP ★ ♡	13012TP ★ ♡	15012TP ★ ♡	100
10 x 1		11016TP ★ ♡	13016TP ★ ♡	15016TP ★ ♡	100
10 x 1 1/4		11020TP ★ ♡	13020TP ★ ♡	15020TP ★ ♡	100
10 x 1 1/2		11024TP ★ ♡	13024TP ★ ♡	15024TP ★ ♡	100
10 x 2		11032TP ★ ♡	13032TP ★ ♡	—	100
12 x 1/2	#12 Spanner	11208TP ★ ♡	13208TP ★ ♡	—	100
12 x 3/4		11212TP ★ ♡	13212TP ★ ♡	—	100
12 x 1		11216TP ★ ♡	13216TP ★ ♡	—	100
12 x 1 1/4		11220TP ★ ♡	13220TP ★ ♡	—	100
12 x 1 1/2		11224TP ★ ♡	13224TP ★ ♡	—	100
12 x 2		11232TP ★ ♡	13232TP ★ ♡	—	100
14 x 1/2	#14 Spanner	11408TP ★ ♡	13408TP ★ ♡	—	100
14 x 3/4		11412TP ★ ♡	13412TP ★ ♡	—	100
14 x 1		11416TP ★ ♡	13416TP ★ ♡	—	100
14 x 1 1/4		11420TP ★ ♡	13420TP ★ ♡	—	100

**Tamperproof Driver Bits Available on page 139**



**Get a 16-in-1 Tamperproof Screwdriver!**

Part #37011.  
See page 135 for details.

★ Made in USA  
♡ Harsh Environment Product

For bulk packaging, contact customer service for quantities and availability.

## BUTTON HEAD SOCKET PIN SHEET METAL SCREWS • STAINLESS STEEL

- Tamperproof screws are available by special order only, are subject to minimum order requirements and are non-returnable. Please allow an extra 5–7 days shipping.

		Cardboard Box	
Size	Driver	Part #	Box Qty
8 x ¾	⅛	10812SP ★ ♡	100
8 x 1		10816SP ★ ♡	100
10 x ½	⅝ <sub>32</sub>	11008SP ★ ♡	100
10 x ¾		11012SP ★ ♡	100
10 x 1		11016SP ★ ♡	100

★ Made in USA    ♡ Harsh Environment Product

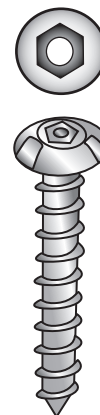

## BUTTON HEAD STAR PIN SHEET METAL SCREWS • STAINLESS STEEL

		Cardboard Box	
Size	Driver	Part #	Box Qty
8 x ½	T-15H	10808XP ★ ♡	100
8 x ¾		10812XP ★ ♡	100
8 x 1		10816XP ★ ♡	100
8 x 1¼		10820XP ★ ♡	100
10 x ½	T-25H	11008XP ★ ♡	100
10 x ¾		11012XP ★ ♡	100
10 x 1		11016XP ★ ♡	100
10 x 1¼		11020XP ★ ♡	100
10 x 1½		11024XP ★ ♡	100

★ Made in USA    ♡ Harsh Environment Product

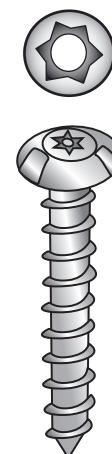

## FLAT HEAD STAR PIN SHEET METAL SCREWS • STAINLESS STEEL

		Cardboard Box	
Size	Driver	Part #	Box Qty
8 x ¾	T-15H	12812XP ★ ♡	100
8 x 1		12816XP ★ ♡	100
8 x 1¼		12820XP ★ ♡	100
10 x ¾	T-20H	13012XP ★ ♡	100
10 x 1		13016XP ★ ♡	100
10 x 1¼		13020XP ★ ♡	100

★ Made in USA    ♡ Harsh Environment Product

For bulk packaging, contact customer service for quantities and availability.

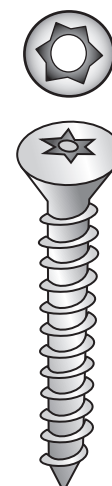

## PAN, FLAT & OVAL SPANNER HEAD MACHINE SCREWS • STAINLESS STEEL

FASTENERS • SCREWS

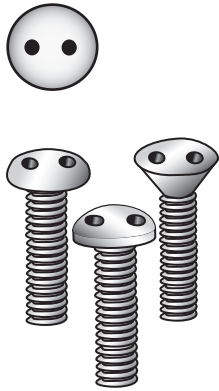

- Tamperproof screws are available by special order only, are subject to minimum order requirements and are non-returnable. Please allow an extra 5–7 days shipping.

		Cardboard Box			
Size	Insert Driver	Pan Head Part #	Flat Head Part #	Oval Head Part #	Box Qty
6-32 x 3/8	#6 Spanner	22506TP ★ ♡	20506TP ★ ♡	25606TP ★ ♡	100
6-32 x 1/2		22508TP ★ ♡	20508TP ★ ♡	25608TP ★ ♡	100
6-32 x 3/4		22512TP ★ ♡	20512TP ★ ♡	25612TP ★ ♡	100
6-32 x 1		22516TP ★ ♡	20516TP ★ ♡	25616TP ★ ♡	100
6-32 x 1 1/4		22520TP ★ ♡	20520TP ★ ♡	25620TP ★ ♡	100
6-32 x 1 1/2		22524TP ★ ♡	20524TP ★ ♡	25624TP ★ ♡	100
6-32 x 2		22532TP ★ ♡	20532TP ★ ♡	—	100
8-32 x 3/8	#8 Spanner	22606TP ★ ♡	20606TP ★ ♡	—	100
8-32 x 1/2		22608TP ★ ♡	20608TP ★ ♡	25808TP ★ ♡	100
8-32 x 3/4		22612TP ★ ♡	20612TP ★ ♡	25812TP ★ ♡	100
8-32 x 1		22616TP ★ ♡	20616TP ★ ♡	25816TP ★ ♡	100
8-32 x 1 1/4		22620TP ★ ♡	20620TP ★ ♡	25820TP ★ ♡	100
8-32 x 1 1/2		22624TP ★ ♡	20624TP ★ ♡	25824TP ★ ♡	100
8-32 x 2		22632TP ★ ♡	20632TP ★ ♡	—	100
10-24 x 1/2	#10 Spanner	22708TP ★ ♡	20708TP ★ ♡	26008TP ★ ♡	100
10-24 x 5/8		22710TP ★ ♡	20710TP ★ ♡	26010TP ★ ♡	100
10-24 x 3/4		22712TP ★ ♡	20712TP ★ ♡	26012TP ★ ♡	100
10-24 x 1		22716TP ★ ♡	20716TP ★ ♡	26016TP ★ ♡	100
10-24 x 1 1/4		22720TP ★ ♡	20720TP ★ ♡	26020TP ★ ♡	100
10-24 x 1 1/2		22724TP ★ ♡	20724TP ★ ♡	26024TP ★ ♡	100
10-24 x 2		22732TP ♡	20732TP ★ ♡	—	100
10-32 x 1/2	#10 Spanner	22808TP ★ ♡	20808TP ★ ♡	26208TP ★ ♡	100
10-32 x 3/4		22812TP ★ ♡	20812TP ★ ♡	26212TP ★ ♡	100
10-32 x 1		22816TP ★ ♡	20816TP ★ ♡	26216TP ★ ♡	100

- ★ Made in USA
- ♡ Harsh Environment Product

For bulk packaging, contact customer service for quantities and availability.

## FLAT & BUTTON HEAD SOCKET PIN MACHINE SCREWS • STAINLESS STEEL

- Tamperproof screws are available by special order only, are subject to minimum order requirements and are non-returnable. Please allow an extra 5–7 days shipping.

Flat Head		Cardboard Box	
Size	Bit	Part #	Box Qty
6-32 x 3/8	1/8	20506SP	100
6-32 x 1/2		20508SP	100
6-32 x 3/4		20512SP	100
6-32 x 1		20516SP	100
8-32 x 3/8	1/8	20606SP	100
8-32 x 1/2		20608SP	100
8-32 x 3/4		20612SP	100
8-32 x 1		20616SP	100
10-24 x 3/8	5/32	20706SP	100
10-24 x 1/2		20708SP	100
10-24 x 3/4		20712SP	100
10-24 x 1		20716SP	100
10-24 x 1 1/2		20724SP	100
10-32 x 1/2	5/32	20808SP	100
10-32 x 3/4		20812SP	100
10-32 x 1		20816SP	100
10-32 x 1 1/2		20824SP	100
1/4-20 x 1/2	5/32	21008SP	100
1/4-20 x 3/4		21012SP	100
1/4-20 x 1		21016SP	100
1/4-20 x 1 1/4		21020SP	100
1/4-20 x 1 1/2		21024SP	100
1/4-20 x 2		21032SP	100

Button Head		Cardboard Box	
Size	Bit	Part #	Box Qty
6-32 x 1/4	1/8	22504SP	100
6-32 x 3/8		22506SP	100
6-32 x 1/2		22508SP	100
6-32 x 3/4		22512SP	100
6-32 x 1		22516SP	100
8-32 x 3/8	1/8	22606SP	100
8-32 x 1/2		22608SP	100
8-32 x 3/4		22612SP	100
8-32 x 1		22616SP	100
8-32 x 1 1/2		22624SP	100
10-24 x 1/4	5/32	22704SP	100
10-24 x 3/8		22706SP	100
10-24 x 1/2		22708SP	100
10-24 x 3/4		22712SP	100
10-24 x 1		22716SP	100
10-24 x 1 1/2		22724SP	100
10-32 x 1/4	5/32	22804SP	100
10-32 x 3/8		22806SP	100
10-32 x 1/2		22808SP	100
10-32 x 3/4		22812SP	100
10-32 x 1		22816SP	100
10-32 x 1 1/4		22820SP	100
10-32 x 1 1/2		22824SP	100
10-32 x 2		22832SP	100



FASTENERS • SCREWS

Larger sizes available upon request.  
For bulk packaging, contact customer service for quantities and availability.

Harsh Environment Product

## FLAT & BUTTON HEAD STAR PIN MACHINE SCREWS • STAINLESS STEEL

Flat Head		Cardboard Box	
Size	Bit	Part #	Box Qty
6-32 x 3/8	T-10H	20506XP	100
6-32 x 1/2		20508XP	100
6-32 x 3/4		20512XP	100
6-32 x 1		20516XP	100
8-32 x 3/8	T-15H	20606XP	100
8-32 x 1/2		20608XP	100
8-32 x 3/4		20612XP	100
8-32 x 1		20616XP	100
10-24 x 1/2	T-20H	20708XP	100
10-24 x 3/4		20712XP	100

Button Head		Cardboard Box	
Size	Bit	Part #	Box Qty
6-32 x 1/4	T-10H	22504XP	100
6-32 x 3/8		22506XP	100
6-32 x 1/2		22508XP	100
6-32 x 3/4		22512XP	100
6-32 x 1		22516XP	100
8-32 x 1/4	T-15H	22604XP	100
8-32 x 3/8		22606XP	100
8-32 x 1/2		22608XP	100
8-32 x 3/4		22612XP	100
8-32 x 1		22616XP	100



Harsh Environment Product

### HEX HEAD CAP SCREWS • 18-8 STAINLESS STEEL

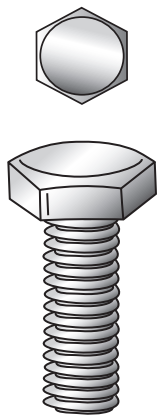

See page 67  
for Stainless  
Steel Split  
Lock Washers.

Size	Cardboard Box		Best Merchandising Option	
	Part #	Box Qty	Gravity Feed Jar	Jar Qty/ Std Pk
1/4-20 x 3/4*	74212 ♡	100	74212J ♡	100/600
1/4-20 x 1*	74216 ♡	100	74216J ♡	100/600
1/4-20 x 1 1/4	74220 ♡	100	74220J ♡	100/600
1/4-20 x 1 1/2	74224 ♡	100	▲	
1/4-20 x 2	74232 ♡	100	▲	
1/4-20 x 2 1/2	74240 ♡	100	▲	
1/4-20 x 3	74248 ♡	100	▲	
5/16-18 x 3/4*	74312 ♡	100	▲	
5/16-18 x 1*	74316 ♡	100	▲	
5/16-18 x 1 1/4	74320 ♡	100	▲	
5/16-18 x 1 1/2	74324 ♡	100	▲	
5/16-18 x 2	74332 ♡	100	▲	
5/16-18 x 2 1/2	74340 ♡	100	▲	
5/16-18 x 3	74348 ♡	100	▲	
3/8-16 x 3/4*	74412 ♡	100	▲	
3/8-16 x 1*	74416 ♡	100	74416J ♡	100/600
3/8-16 x 1 1/4*	74420 ♡	100	74420J ♡	100/600
3/8-16 x 1 1/2	74424 ♡	100	74424J ♡	100/600
3/8-16 x 2	74432 ♡	50	▲	
3/8-16 x 2 1/2	74440 ♡	50	▲	
3/8-16 x 3	74448 ♡	50	▲	
1/2-13 x 3/4*	74612 ♡	50	▲	
1/2-13 x 1*	74616 ♡	50	▲	
1/2-13 x 1 1/4*	74620 ♡	50	▲	
1/2-13 x 1 1/2*	74624 ♡	50	▲	
1/2-13 x 2	74632 ♡	50	▲	
1/2-13 x 2 1/2	74640 ♡	50	▲	
1/2-13 x 3	74648 ♡	50	▲	

▲ Contact customer service for gravity feed jar availability.

\*These sizes are fully threaded.

♡ Harsh Environment Product

For bulk packaging, contact customer service for quantities and availability.

## HEX HEAD CAP SCREWS • SILICON BRONZE

Size	Cardboard Box		Best Merchandising Option	
	Part #	Box Qty	Gravity Feed Jar	Jar Qty/Std Pk
1/4-20 x 1/2*	54108	100	▲	
1/4-20 x 5/8*	54110	100	▲	
1/4-20 x 3/4*	54112	100	▲	
1/4-20 x 1*	54116	100	▲	
1/4-20 x 1 1/4	54120	100	▲	
1/4-20 x 1 1/2	54124	100	▲	
1/4-20 x 2	54132	100	▲	
5/16-18 x 1/2*	54208	100	▲	
5/16-18 x 3/4*	54212	100	▲	
5/16-18 x 1*	54216	100	54216J	100/600
5/16-18 x 1 1/4	54220	100	▲	
5/16-18 x 1 1/2	54224	100	▲	
5/16-18 x 2	54232	100	▲	
3/8-16 x 1/2*	54408	100	▲	
3/8-16 x 3/4*	54412	100	▲	
3/8-16 x 1*	54416	100	▲	
3/8-16 x 1 1/4*	54420	100	▲	
3/8-16 x 1 1/2	54424	100	54424J	100/600
3/8-16 x 2	54432	50	▲	
3/8-16 x 2 1/2	54440	50	▲	
3/8-16 x 3	54448	50	▲	
3/8-16 x 3 1/2	54456	50	▲	
3/8-16 x 4	54464	50	▲	
1/2-13 x 3/4*	54812	50	▲	
1/2-13 x 1*	54816	50	▲	
1/2-13 x 1 1/4*	54820	50	▲	
1/2-13 x 1 1/2*	54824	50	54824J	100/600
1/2-13 x 1 3/4	54828	50	▲	
1/2-13 x 2	54832	50	54832J	50/300
1/2-13 x 2 1/2	54840	50	54840J	50/300
1/2-13 x 3	54848	50	54848J	50/300
1/2-13 x 3 1/2	54856	25	▲	
1/2-13 x 4	54864	25	▲	

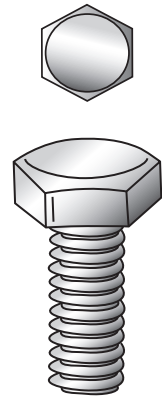

See page 67 for Silicon Bronze Split Lock Washers.

FASTENERS • SCREWS

▲ Contact customer service for gravity feed jar availability.  
 \*These sizes are fully threaded.  
 ▽ Harsh Environment Product

For bulk packaging, contact customer service for quantities and availability.

### ROUND & FLAT HEAD BRASS MACHINE SCREWS • SLOTTED

FASTENERS • SCREWS

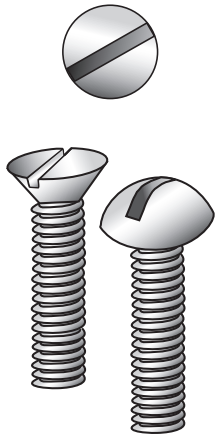

▲ Contact customer service for gravity feed jar availability.

♣ Harsh Environment Product

For bulk packaging, contact customer service for quantities and availability.

Round Head	♣ Plastic Box		Best Merchandising Option	
	Size	Part #	Box Qty	Gravity Feed Jar
6-32 x 1/2	51208 ♣	100	▲	
6-32 x 3/4	51212 ♣	100	▲	
6-32 x 1	51216 ♣	100	▲	
8-32 x 3/4	51412 ♣	100	▲	
8-32 x 1	51416 ♣	100	▲	
8-32 x 1 1/4	51420 ♣	100	▲	
8-32 x 1 1/2	51424 ♣	100	▲	
8-32 x 2	51432 ♣	100	▲	
10-24 x 3/4	51512 ♣	100	▲	
10-24 x 1	51516 ♣	100	▲	
10-24 x 1 1/4	51520 ♣	100	▲	
10-24 x 1 1/2	51524 ♣	100	▲	
10-24 x 2	51532 ♣	50	▲	
10-32 x 3/8	51706 ♣	100	▲	
10-32 x 1/2	51708 ♣	100	▲	
10-32 x 3/4	51712 ♣	100	▲	
10-32 x 1	51716 ♣	100	▲	
10-32 x 1 1/4	51720 ♣	100	▲	
10-32 x 1 1/2	51724 ♣	50	▲	
1/4-20 x 3/8	51806 ♣	100	▲	
1/4-20 x 1/2	51808 ♣	100	▲	
1/4-20 x 3/4	51812 ♣	100	▲	
1/4-20 x 1	51816 ♣	50	▲	
1/4-20 x 1 1/4	51820 ♣	50	51820J ♣	100/600
1/4-20 x 1 1/2	51824 ♣	50	51824J ♣	100/600
1/4-20 x 2	51832 ♣	50	▲	

Flat Head	♣ Plastic Box		Best Merchandising Option	
	Size	Part #	Box Qty	Gravity Feed Jar
6-32 x 1/2	56108 ♣	100	▲	
6-32 x 3/4	56112 ♣	100	▲	
6-32 x 1	56116 ♣	100	▲	
8-32 x 3/4	56312 ♣	100	▲	
8-32 x 1	56316 ♣	100	▲	
8-32 x 1 1/4	56320 ♣	100	▲	
8-32 x 1 1/2	56324 ♣	100	▲	



## SCREW HOOKS • ZINC

						Best Merchandising Option			
						Cardboard Box		Gravity Feed Jar	
Size	Wire Diameter	Overall Length	Proj. Length	Wire Gauge	Hook Opening	Part #	Box Qty	Part #	Jar Qty/ Std Pk
0	3/8	4 5/16	3 1/16	0	1 1/32	<b>65000</b> ★	50	▲	
2	2 1/64	4 7/16	3 3/16	2	1	<b>65002</b> ★	50	▲	
4	1 7/64	3 7/8	2 5/8	4	2 7/32	<b>65004</b> ★	50	▲	
6	1 5/64	3 3/8	2 1/8	6	2 5/32	<b>65006</b> ★	100	▲	
8	3/16	2 9/16	1 11/16	8	1 7/32	<b>65008</b> ★	100	▲	
10	1 1/64	2 1/16	1 3/8	10	1 3/32	<b>65010</b> ★	100	▲	
12	1/8	1 11/16	1 1/16	12	9/32	<b>65012</b> ★	100	▲	

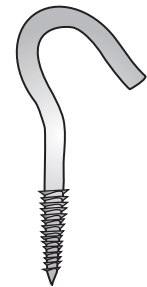

FASTENERS • SCREWS

★ Made in USA

## SCREW EYES • ZINC

						Best Merchandising Option			
						Cardboard Box		Gravity Feed Jar	
Size	Wire Diameter	Overall Length	Shank Length	Wire Gauge	Inside Eye Dia.	Part #	Box Qty	Part #	Jar Qty/ Std Pk
0	5/16	3 3/16	1 1/16	0	1 3/16	<b>66400</b> ★	50	▲	
2	1 7/64	2 1 1/16	1 13/32	2	2 3/32	<b>66402</b> ★	50	▲	
4	1 7/64	2 3/16	1 1/8	4	3 9/64	<b>66404</b> ★	50	▲	
6	1 5/64	1 15/16	3 1/32	6	1 7/32	<b>66406</b> ★	50	▲	
8	3/16	1 5/8	1 3/16	8	1 5/32	<b>66408</b> ★	100	▲	
10	1 1/64	1 3/8	1 1/16	10	1 3/32	<b>66410</b> ★	100	▲	
12	1/8	1 3/16	3 5/64	12	3/8	<b>66412</b> ★	100	▲	
14	3/32	1 1/16	1/2	14	1 1/32	<b>66414</b> ★	100	▲	

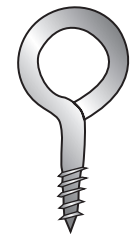

★ Made in USA

▲ Contact customer service for gravity feed jar availability.

For bulk packaging, contact customer service for quantities and availability.

## SCREW EYE LAGS • ZINC

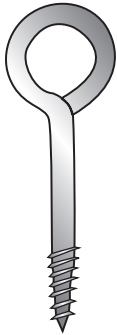

					Best Merchandising Option			
					Cardboard Box		Gravity Feed Jar	
Thread Diameter	Overall Length	Shank Length	Thread Length	Inside Eye Diameter	Part #	Box Qty	Part #	Jar Qty/Std Pk
1/4	3 3/4	2 3/4	1 5/16	1/2	66466 ★	100	66466J	100/600
1/4	5	4	1 7/8	1/2	66467 ★	100	▲	

★ Made in USA

FASTENERS • SCREWS

## ACOUSTICAL EYE LAGS & ACOUSTICAL EYE TEKS • ZINC

- Eye lags install easily with the acoustical eye teks.
- For use with tie wire, ceiling wire and jack chain applications.

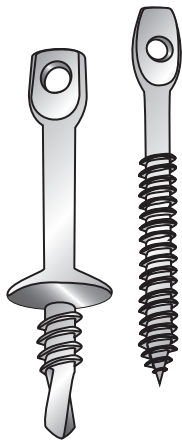

		Best Merchandising Option					
		Cardboard Box		Gravity Feed Jar		Job Jar	
Size	Application	Part #	Box Qty	Part #	Jar Qty/Std Pk	Part #	Jar Qty
1/4 x 3	Wood	59248	100	59248J	100/600	—	—
1/4 x 4	Wood	59264	100	▲		—	—
1/4 x 5	Wood	59280	100	▲		—	—
1/4 x 2	Metal*	59251	100	59251J	100/600	—	—

\*Acoustical Eye Tek

### Acoustical Eye Driver Installs Eye Lags & Eye Tekes



Size	Part #	Box Qty
Heavy Duty	59250	1

▲ Contact customer service for gravity feed jar availability.

For bulk packaging, contact customer service for quantities and availability.

## GREEN GROUNDING SCREWS • ZINC

- Type C Point is also known as a pilot point or dog point.
- Type F Point is thread cutting.

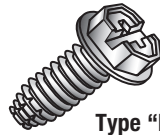

Type "F" Point



Type "C" Point



			Best Merchandising Option					
			100 Packs	Gravity Feed Jar	Job Jar			
Size	Head Style	Point Type	Part #	Box Qty/ Std Pk	Part #	Jar Qty/ Std Pk	Part #	Jar Qty
10-32 x 3/8"	Hex Washer Head 5/16" Slot/Phil	Type F	<b>80006</b>	100/500	<b>80006J</b>	100/1200	<b>80006-6</b>	1000
10-32 x 3/8"	Round Washer Head Phil	Type C	<b>80017</b>	100/500	<b>80017J</b>	100/1200	<b>80017-6</b>	1000
10-32 x 3/8"	Hex Washer Head Quad Drive	Type C	<b>80022</b>	100/500	<b>80022J</b>	100/1200	—	

## GROUNDING PIGTAILS WITH GROUNDING SCREWS • QUAD DRIVE • INSULATED

				Plastic Bag	
Gauge	Length	Point Size	Lead Style	Part #	Qty
#12	6"	Solid	Bare Wire Lead	<b>80007</b>	50
#14	6 1/2"	Solid	Bare Wire Lead	<b>80016</b>	50
#12	7 1/2"	Solid	Bare Wire Lead	<b>80018</b>	50
#12	8"	Stranded	Forked Terminal	<b>80015</b>	50
#12	9"	Solid	Bare Wire Lead	<b>80021</b>	50
#12	10"	Solid	Bare Wire Lead	<b>80020</b>	50



## GREEN GROUNDING CLIPS • GREEN ZINC CHROMATE

- Connects non-metallic sheathed cable grounding conductor to outlet boxes.
- Press onto top edge of box to hold grounding conductor against side wall.
- Designed to fit all common sizes of copper or aluminum wire.



			Best Merchandising Option			
			Plastic Box	Gravity Feed Jar	Job Jar	
Gauge	Part #	Box Qty/ Std Pk	Part #	Jar Qty/ Std Pk	Part #	Jar Qty
Universal #10-12-14	<b>80011</b>	100/500	<b>80011J</b>	100/1200	—	

For bulk packaging, contact customer service for quantities and availability.

### CONDUIT HUBS • BRASS



**Cardboard Box**

Description	Part #	Box Qty
1/2" Conduit Hub	95050 ▾	10
3/4" Conduit Hub	95052 ▾	10
1" Conduit Hub	95054 ▾	10

### GROUND ROD CLAMPS • FOR DIRECT BURIAL • BRASS

Harsh Environment Product



**Cardboard Box**

Description	Part #	Box Qty
1/2" Ground Rod Clamp with Bronze or Stainless Screws	95070 ▾	10
5/8" Ground Rod Clamp with Bronze or Stainless Screws	95072 ▾	10
3/4" Ground Rod Clamp with Bronze or Stainless Screws	95074 ▾	10

### GROUND CLAMPS

Harsh Environment Product

• Fits #2, 4, 6, 8 and 10 AWG copper.



**Cardboard Box**

Description	Metal	Application	Part #	Box Qty
1/2" – 1" Ground Clamp	Zinc	Copper and Aluminum Wire	95150	10
1/2" – 1" Ground Clamp (Brass-Plated)	Zinc	Bare Wire – Non UL	95151	10
1/2" – 1" Ground Clamp	Brass	Bare Wire	95152 ▾	10
1 1/4" – 2" Ground Clamp	Brass	Bare Wire	95156 ▾	10
2 1/2" – 4" Ground Clamp	Brass	Bare Wire	95158 ▾	10
1/2" – 1" Ground Clamp	Bronze	Direct Burial	95154 ▾	10

### ARMORED GROUND CLAMPS • BRASS

Harsh Environment Product



• Fits 4, 6 and 8 bare armored ground wire copper.



**Cardboard Box**

Description	Metal	Part #	Box Qty
1/2" – 1" Armored Ground Clamp	Brass	95168 ▾	10
1 1/4" – 2" Armored Ground Clamp	Brass	95170 ▾	10

### GROUND CLAMPS WITH THREADED HUBS • BRASS

Harsh Environment Product



**Cardboard Box**

Description	Application	Part #	Box Qty
1/2" – 1" Ground Clamp with 1/2" Hub	For Conduit Pipe	95190 ▾	10
1/2" – 1" Ground Clamp with 3/4" Hub	For Conduit Pipe	95192 ▾	10
1/2" – 1" Ground Clamp with 1" Hub	For Conduit Pipe	95194 ▾	10

Harsh Environment Product

## HEX NUTS • ZINC PLATED

		Best Merchandising Option						
		Cardboard Box	Gravity Feed Jar		Job Jar			
				HEAVY DUTY				
Size	Part #	Box Qty	Part #	Jar Qty/ Std Pk	Part #	Jar Qty/ Std Pk	Part #	Jar Qty
4-40	<b>40103</b>	100	▲		▲		—	
6-32	<b>40105</b>	100	<b>40105J</b>	100/1200	▲		—	
8-32	<b>40110</b>	100	<b>40110J</b>	100/1200	▲		—	
10-24	<b>40115</b>	100	<b>40115J</b>	100/1200	▲		—	
10-32	<b>40120</b>	100	<b>40120J</b>	100/1200	▲		—	
12-24	<b>40122</b>	100	▲		▲		—	
¼-20	<b>40125</b>	100	<b>40125J</b>	100/1200	▲		<b>40125-6</b>	750
¼-28	<b>40126</b>	100	▲		▲		—	
⅝-18	<b>40130</b>	100	<b>40130J</b>	100/1200	▲		—	
⅜-16	<b>40135</b>	100	<b>40135J</b>	100/600	<b>40135HJ</b>	100/600	<b>40135-6</b>	250
7/16-14	<b>40137</b>	100	▲		▲		—	
½-13	<b>40140</b>	100	<b>40140J</b>	100/600	<b>40140HJ</b>	100/600	<b>40140-6</b>	150
⅝-11	<b>40145</b>	50	<b>40145J</b>	50/300	▲		—	
¾-10	<b>40150</b>	50	<b>40150J</b>	50/300	<b>40150HJ</b>	50/300	—	
1-8	<b>40155</b>	10	▲		▲		—	



FASTENERS • NUTS/WASHERS

Kits			
Part #	Description		
<b>39516</b> (405 Piece Kit)	<b>Hex Nut Zinc Plated Kit</b>		
	6-32 (100 Pieces)	8-32 (100 Pieces)	10-32 (100 Pieces)
	¼-20 (50 Pieces)	⅝-18 (35 Pieces)	⅜-16 (20 Pieces)

▲ Contact customer service for gravity feed jar availability.

For bulk packaging, contact customer service for quantities and availability.

### HEX NUTS • BRASS



Size	Cardboard Box		Best Merchandising Option		Job Jar	
	Part #	Box Qty	Part #	Jar Qty/ Std Pk	Part #	Jar Qty
6-32	43105	100	▲			—
8-32	43110	100	▲			—
10-24	43115	100	▲			—
10-32	43120	100	▲			—
12-24	43122	100	▲			—
¼-20	43125	100	43125J	100/1200		—
⅝-18	43130	100	▲			—
⅜-16	43135	100	▲			—
½-13	43140	100	▲			—

### HEX NUTS • SILICON BRONZE



Size	Cardboard Box		Best Merchandising Option		Job Jar	
	Part #	Box Qty	Part #	Jar Qty/ Std Pk	Part #	Jar Qty
8-32	41110	100	▲			—
10-24	41115	100	▲			—
10-32	41120	100	▲			—
12-24	41122	100	▲			—
¼-20	41125	100	41125J	100/1200		—
⅝-18	41130	100	41130J	100/1200		—
⅜-16	41135	100	41135J	100/600		—
½-13	41140	100	41140J	100/600		—
⅝-11	41145	100	▲			—

▲ Contact customer service for gravity feed jar availability.

Harsh Environment Product

For bulk packaging, contact customer service for quantities and availability.

## HEX NUTS • STAINLESS STEEL

Size	Cardboard Box		Best Merchandising Option		Job Jar	
	Part #	Box Qty	Part #	Jar Qty/Std Pk	Part #	Jar Qty
6-32	70105 ▾	100	70105J ▾	100/1200	—	—
8-32	70110 ▾	100	▲		—	—
10-24	70115 ▾	100	▲		—	—
10-32	70120 ▾	100	70120J ▾	100/1200	—	—
12-24	70122 ▾	100	▲		—	—
¼-20	70125 ▾	100	70125J ▾	100/1200	—	—
⅝-18	70130 ▾	100	▲		—	—
⅜-16	70135 ▾	100	70135J ▾	100/600	—	—
7/16-14	70137 ▾	100	▲		—	—
½-13	70140 ▾	100	70140J ▾	100/600	—	—
⅝-11	70145 ▾	100	▲		—	—

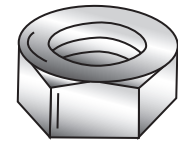

▾ Harsh Environment Product

## FLANGE WHIZ NUTS • ZINC

Size	Cardboard Box		Best Merchandising Option		Job Jar	
	Part #	Box Qty	Part #	Jar Qty/Std Pk	Part #	Jar Qty
¼ x 20	40480	100	40480J	100/1200	—	—
⅝ x 18	40481	100	40481J	100/1200	—	—
⅜ x 16	40482	100	40482J	100/600	—	—
½ x 13	40483	100	40483J	100/600	—	—



## GRADE 5 HEX NUTS

Size	Cardboard Box		Best Merchandising Option		Job Jar		
	Part #	USA Part #	Part #	USA Part #	Jar Qty/Std Pk	Part #	Jar Qty
¼-20	40225	40225US ★	100	▲		—	—
⅝-18	40230	40230US ★	100	▲		—	—
⅜-16	40235	40235US ★	100	40235J	40235USJ ★	100/600	—
½-13	40240	40240US ★	50	40240J	40240USJ ★	100/600	—
¾-10	40250	40250US ★	50	▲		—	—



▲ Contact customer service for gravity feed jar availability.

★ Made in USA

For bulk packaging, contact customer service for quantities and availability.

## NYLOCK HEX NUTS

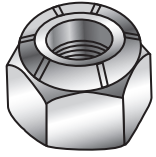

FASTENERS • NUTS/WASHERS

			Best Merchandising Option			
			Cardboard Box	Gravity Feed Jar	Job Jar	
Size	Part #	Box Qty	Part #	Jar Qty/ Std Pk	Part #	Jar Qty
4-40	40402	100		▲		—
6-32	40405	100		▲		—
8-32	40411	100		▲		—
10-32	40416	100		▲		—
10-24	40420	100		▲		—
¼-20	40425	100	40425J	100/600		—
⅝-18	40430	100		▲		—
⅜-16	40435	100	40435J	100/600		—
½-13	40440	100		▲		—

## NYLOCK HEX NUTS • STAINLESS STEEL

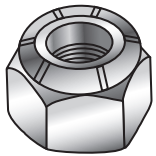

			Best Merchandising Option			
			Cardboard Box	Gravity Feed Jar	Job Jar	
Size	Part #	Box Qty	Part #	Jar Qty/ Std Pk	Part #	Jar Qty
6-32	70405 ♡	100		▲		—
8-32	70410 ♡	100		▲		—
10-24	70415 ♡	100		▲		—
10-32	70420 ♡	100		▲		—
¼-20	70425 ♡	100		▲		—
⅝-18	70430 ♡	100		▲		—
⅜-16	70435 ♡	100		▲		—
½-13	70440 ♡	100		▲		—
⅝-11	70445 ♡	100		▲		—

▲ Contact customer service for gravity feed jar availability.

♡ Harsh Environment Product

For bulk packaging, contact customer service for quantities and availability.



## SPECIALTY NUTS • CAP NUTS

		Best Merchandising Option				
		Cardboard Box	Gravity Feed Jar		Job Jar	
Size	Part #	Box Qty	Part #	Jar Qty/ Std Pk	Part #	Jar Qty
8-32	<b>41310</b>	100		▲		—
10-24	<b>41315</b>	100		▲		—
10-32	<b>41320</b>	100		▲		—
¼-20	<b>41325</b>	100		▲		—
⅝-18	<b>41331</b>	100		▲		—
⅜-16	<b>41336</b>	100		▲		—
½-13	<b>41341</b>	100		▲		—

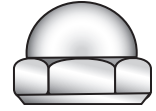

## SPECIALTY NUTS • WING NUTS

		Best Merchandising Option				
		Cardboard Box	Gravity Feed Jar		Job Jar	
Size	Part #	Box Qty	Part #	Jar Qty/ Std Pk	Part #	Jar Qty
10-24	<b>41415</b>	100		▲		—
10-32	<b>41420</b>	100		▲		—
¼-20	<b>41425</b>	100		▲		—
⅝-18	<b>41430</b>	100		▲		—
⅜-16	<b>41435</b>	100		▲		—



▲ Contact customer service for gravity feed jar availability.

For bulk packaging, contact customer service for quantities and availability.

## TOOTHED LOCK WASHERS • INTERNAL • ZINC PLATED



Size	Cardboard Box		Best Merchandising Option		Job Jar	
	Part #	Box Qty	Part #	Jar Qty/Std Pk	Part #	Jar Qty
#6	40605	100	▲		—	
#8	40610	100	▲		—	
#10 (3/16)	40615	100	▲		—	
1/4	40620	100	▲		—	
5/16	40625	100	▲		—	

## TOOTHED LOCK WASHERS • EXTERNAL • ZINC PLATED

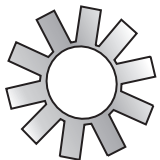

Size	Cardboard Box		Best Merchandising Option		Job Jar	
	Part #	Box Qty	Part #	Jar Qty/Std Pk	Part #	Jar Qty
#6	40606	100	40606J	100/1200	—	
#8	40611	100	▲		—	
#10 (3/16)	40616	100	▲		—	
1/4	40621	100	40621J	100/1200	—	
5/16	40626	100	▲		—	

## SPECIALTY WASHERS • SEALING WASHERS • GALVANIZED

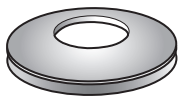

Size	Cardboard Box		Best Merchandising Option		Job Jar	
	Part #	Box Qty	Part #	Jar Qty/Std Pk	Part #	Jar Qty
#10	40410	100	▲		—	
#12	40412	100	▲		—	
1/4	40414	100	▲		—	

Galvanized with Rubber Washer.

## SPECIALTY WASHERS • OCTAGONAL • ZINC



Size	Cardboard Box		Best Merchandising Option		Job Jar	
	Part #	Box Qty	Part #	Jar Qty/Std Pk	Part #	Jar Qty
1/4 x 1 3/8	40760	100	40760J	100/600	—	
3/8 x 1 3/8	40762	100	40762J	100/600	—	

▲ Contact customer service for gravity feed jar availability.

For bulk packaging, contact customer service for quantities and availability.

## SPECIALTY WASHERS • BELLEVILLE • SPRING STEEL

		Best Merchandising Option				
		Cardboard Box	Gravity Feed Jar		Job Jar	
Size	Spring Force	Part #	Box Qty	Part #	Jar Qty/ Std Pk	Part # Jar Qty
¼	569#	40905	100	▲		—
⅝	1682#	40910	100	▲		—
⅜	1700#	40915	100	▲		—
½	2337#	40925	100	▲		—



## SPECIALTY WASHERS • BELLEVILLE • STAINLESS STEEL

		Best Merchandising Option				
		Cardboard Box	Gravity Feed Jar		Job Jar	
Size	Spring Force	Part #	Box Qty	Part #	Jar Qty/ Std Pk	Part # Jar Qty
½	2337#	40925SS	100	40925SSJ	100/600	—



## FINISH CUP WASHERS • BRASS

		Best Merchandising Option				
		Cardboard Box	Gravity Feed Jar		Job Jar	
Size		Part #	Box Qty	Part #	Jar Qty/ Std Pk	Part # Jar Qty
#6		43805	100	▲		—
#8		43810	100	▲		—
#10		43815	100	▲		—



## FINISH CUP WASHERS • STAINLESS STEEL

		Best Merchandising Option				
		Cardboard Box	Gravity Feed Jar		Job Jar	
Size		Part #	Box Qty	Part #	Jar Qty/ Std Pk	Part # Jar Qty
#6		71105	100	▲		—
#8		71110	100	▲		—
#10		71115	100	▲		—
#12		71120	100	▲		—
¼"		71125	100	▲		—
⅜"		71135	100	▲		—



▲ Contact customer service for gravity feed jar availability.

Harsh Environment Product

For bulk packaging, contact customer service for quantities and availability.

### FLAT CUT WASHERS • ZINC PLATED

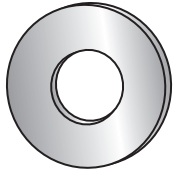

FASTENERS • NUTS/WASHERS

Size	Cardboard Box		Best Merchandising Option		Job Jar	
	Part #	Box Qty	Part #	Jar Qty/Std Pk	Part #	Jar Qty
#6	40305	100	40305J	100/1200	—	—
#8	40310	100	40310J	100/1200	—	—
#10	40315	100	40315J	100/1200	—	—
#12	40317	100	40317J	100/1200	—	—
¼"	40325	100	40325J	100/1200	40325-6	1000
⅝"	40330	100	40330J	100/1200	—	—
⅜"	40335	100	40335J	100/600	40335-6	250
½"	40340	100	40340J	100/600	40340-6	150
⅝"	40345	100	40345J	100/600	—	—
¾"	40350	100	40350J	100/600	—	—

SAE	Best Merchandising Option	
	Part #	Jar Qty/Std Pk
#6	40305SAEJ	100/1200
#8	40310SAEJ	100/1200
⅝"	40330SAEJ	100/1200
½"	40340SAEJ	100/600

Kits		
Part #	Description	
<b>Flat Cut Washer Kit</b>		
<b>39518</b>	#8 (100 Pieces)	¼" (100 Pieces)
(370 Pc Kit)	#10 (100 Pieces)	⅝" (35 Pieces)
		⅜" (35 Pieces)

### FLAT CUT WASHERS • STAINLESS STEEL

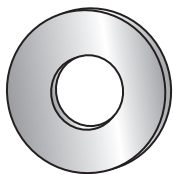

Size	Cardboard Box		Best Merchandising Option		Job Jar	
	Part #	Box Qty	Part #	Jar Qty/Std Pk	Part #	Jar Qty
#6	70305 ♡	100	70305J ♡	100/1200	—	—
#8	70310 ♡	100	70310J ♡	100/1200	—	—
#10	70315 ♡	100	70315J ♡	100/1200	—	—
¼"	70325 ♡	100	70325J ♡	100/1200	—	—
⅝"	70330 ♡	100	▲	—	—	—
⅜"	70335 ♡	100	70335J ♡	100/1200	—	—
⅞"	70337 ♡	100	▲	—	—	—
½"	70340 ♡	100	▲	—	—	—
⅝"	70345 ♡	100	▲	—	—	—

▲ Contact customer service for gravity feed jar availability.  
 ♡ Harsh Environment Product

For bulk packaging, contact customer service for quantities and availability.

## FLAT CUT WASHERS • SILICON BRONZE

Size	Cardboard Box		Best Merchandising Option		Job Jar	
	Part #	Box Qty	Part #	Jar Qty/ Std Pk	Part #	Jar Qty
#8	42310	100	▲			—
#10	42315	100	▲			—
1/4"	42325	100	▲			—
5/16"	42330	100	▲			—
3/8"	42335	100	▲			—
1/2"	42340	100	42340J	100/600		—
5/8"	42345	100	▲			—
3/4"	42350	100	▲			—

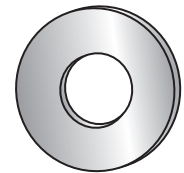

## FLAT CUT WASHERS • BRASS

Size	Cardboard Box		Best Merchandising Option		Job Jar	
	Part #	Box Qty	Part #	Jar Qty/ Std Pk	Part #	Jar Qty
#6	43305	100	▲			—
#8	43310	100	▲			—
#10	43315	100	▲			—
#12	43320	100	▲			—
1/4"	43325	100	▲			—
5/16"	43330	100	▲			—
3/8"	43335	100	▲			—
1/2"	43340	100	▲			—
5/8"	43345	100	▲			—
3/4"	43350	100	▲			—

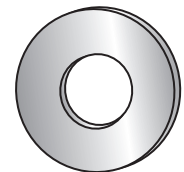

▲ Contact customer service for gravity feed jar availability.

Harsh Environment Product

For bulk packaging, contact customer service for quantities and availability.

## FENDER WASHERS • ZINC PLATED

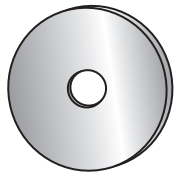

FASTENERS • NUTS/WASHERS

Size	Cardboard Box		Best Merchandising Option		Job Jar	
	Part #	Box Qty	Part #	Jar Qty/Std Pk	Part #	Jar Qty
1/8 x 1"	40705	100	40705J	100/1200	—	—
3/16 x 1"	40709	100	40709J	100/1200	—	—
3/16 x 1 1/8"	40710	100	40710J	100/1200	—	—
3/16 x 1 1/4"	40715	100	40715J	100/1200	—	—
1/4 x 1"	40720	100	40720J	100/1200	40720-6	350
1/4 x 1 1/4"	40725	100	40725J	100/600	40725-6	250
1/4 x 1 1/2"	40730	100	40730J	100/600	40730-6	250
1/4 x 2"	40733	100	40733J	100/600	—	—
5/16 x 1 1/4"	40735	100	40735J	100/600	—	—
5/16 x 1 1/2"	40740	100	40740J	100/600	—	—
3/8 x 1 1/4"	40743	100	40743J	100/600	40743-6	250
3/8 x 1 1/2"	40745	100	40745J	100/600	40745-6	250
1/2 x 1 1/2"	40750	100	40750J	100/600	—	—
1/2 x 2"	40755	100	40755J	100/600	—	—

Kits			
Part #	Description		
39519	Fender Washer Kit		
(120 Pc Kit)	3/16 x 1 1/4" (40 Pcs)	1/4 x 1 1/4" (40 Pcs)	3/8 x 1 1/4" (40 Pcs)

## FENDER WASHERS • STAINLESS STEEL



Size	Cardboard Box		Best Merchandising Option		Job Jar	
	Part #	Box Qty	Part #	Jar Qty/Std Pk	Part #	Jar Qty
3/16 x 1"	70709	100	▲	—	—	—
3/16 x 1 1/16"	70710	100	▲	—	—	—
1/4 x 1"	70720	100	70720J	100/1200	—	—
1/4 x 1 1/4"	70725	100	70725J	100/600	—	—
1/4 x 1 1/2"	70730	100	70730J	100/600	—	—
5/16 x 1 1/2"	70740	100	▲	—	—	—
3/8 x 1 1/4"	70743	100	▲	—	—	—
3/8 x 1 1/2"	70745	100	70745J	100/600	—	—

▲ Contact customer service for gravity feed jar availability.  
 ▼ Harsh Environment Product

For bulk packaging, contact customer service for quantities and availability.

## SPLIT LOCK WASHERS • SILICON BRONZE

Size	Cardboard Box		Best Merchandising Option		Job Jar	
	Part #	Box Qty	Part #	Jar Qty/ Std Pk	Part #	Jar Qty
#6	42505	100	▲			—
#8	42510	100	▲			—
#10	42515	100	42515J	100/1200		—
#12	42517	100	▲			—
1/4"	42525	100	42525J	100/1200		—
5/16"	42530	100	▲			—
3/8"	42535	100	▲			—
1/2"	42540	100	42540J	100/600		—
5/8"	42545	100	▲			—
3/4"	42550	100	▲			—

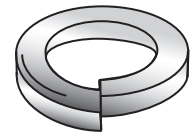

## SPLIT LOCK WASHERS • STAINLESS STEEL

Size	Cardboard Box		Best Merchandising Option		Job Jar	
	Part #	Box Qty	Part #	Jar Qty/ Std Pk	Part #	Jar Qty
#6	70505	100	70505J	100/600		—
#8	70510	100	▲			—
#10	70515	100	70515J	100/600		—
1/4"	70525	100	70525J	100/600		—
5/16"	70530	100	70530J	100/600		—
3/8"	70535	100	70535J	100/600		—
7/16"	70537	100	▲			—
1/2"	70540	100	70540J	100/600		—
5/8"	70545	100	▲			—



▲ Contact customer service for gravity feed jar availability.

Harsh Environment Product

For bulk packaging, contact customer service for quantities and availability.

## SPLIT LOCK WASHERS • ZINC PLATED

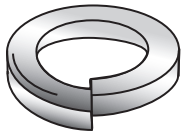

FASTENERS • NUTS/WASHERS

Size	Cardboard Box		Gravity Feed Jar		Job Jar	
	Part #	Box Qty	Part #	Jar Qty/ Std Pk	Part #	Jar Qty
#6	40505	100	40505J	100/1200	—	—
#8	40510	100	40510J	100/1200	—	—
#10	40515	100	40515J	100/1200	—	—
#12	40517	100	40517J	100/1200	—	—
¼"	40525	100	40525J	100/1200	—	—
⅝"	40530	100	40530J	100/1200	—	—
⅜"	40535	100	40535J	100/1200	—	—
½"	40540	100	40540J	100/600	—	—
⅝"	40545	100	40545J	100/600	—	—

Kits			
Part #	Description		
39517 (425 Piece Kit)	Split Lock Washer Kit		
	#8 (100 Pieces)	¼" (100 Pieces)	⅝" (60 Pieces)
	#10 (100 Pieces)	⅜" (40 Pieces)	½" (25 Pieces)

For bulk packaging, contact customer service for quantities and availability.



## HEX LAG SCREWS • ZINC PLATED

		Best Merchandising Option			
		Cardboard Box	Gravity Feed Jar	Job Jar	
Size	Part #	Box Qty	Part #	Jar Qty/ Std Pk	Part # Jar Qty
¼ x 1	<b>57016</b>	100	<b>57016J</b>	100/600	—
¼ x 1¼	<b>57020</b>	100	<b>57020J</b>	100/600	—
¼ x 1½	<b>57024</b>	100	<b>57024J</b>	100/600	—
¼ x 2	<b>57032</b>	100	<b>57032J</b>	100/600	—
¼ x 2½	<b>57040</b>	100	<b>57040J</b>	100/600	—
¼ x 3	<b>57048</b>	100	<b>57048J</b>	100/600	—
¼ x 3½	<b>57056</b>	100	<b>57056J</b>	50/300	—
¼ x 4	<b>57064</b>	100	<b>57064J</b>	100/600	—
⅓ x 1	<b>57216</b>	100	▲		—
⅓ x 1¼	<b>57220</b>	100	▲		—
⅓ x 1½	<b>57224</b>	100	<b>57224J</b>	100/600	—
⅓ x 2	<b>57232</b>	100	<b>57232J</b>	100/600	—
⅓ x 2½	<b>57240</b>	100	<b>57240J</b>	100/600	—
⅓ x 3	<b>57248</b>	100	<b>57248J</b>	100/600	—
⅓ x 3½	<b>57256</b>	50	▲		—
⅓ x 4	<b>57264</b>	50	<b>57264J</b>	100/600	—
⅜ x 1	<b>57416</b>	100	<b>57416J</b>	100/600	—
⅜ x 1¼	<b>57420</b>	100	<b>57420J</b>	100/600	—
⅜ x 1½	<b>57424</b>	100	<b>57424J</b>	100/600	—
⅜ x 2	<b>57432</b>	50	<b>57432J</b>	100/600	—
⅜ x 2½	<b>57440</b>	50	<b>57440J</b>	50/300	—
⅜ x 3	<b>57448</b>	50	<b>57448J</b>	50/300	—
⅜ x 3½	<b>57456</b>	50	<b>57456J</b>	50/300	—
⅜ x 4	<b>57464</b>	50	<b>57464J</b>	50/300	—
⅜ x 4½	<b>57472</b>	50	▲		—
⅜ x 5	<b>57480</b>	50	<b>57480J</b>	50/300	—
⅜ x 5½	<b>57488</b>	50	▲		—
⅜ x 6	<b>57496</b>	50	▲		—
½ x 1½	<b>57824</b>	50	<b>57824J</b>	50/300	—
½ x 2	<b>57832</b>	50	▲		—
½ x 2½	<b>57840</b>	50	▲		—
½ x 3	<b>57848</b>	50	<b>57848J</b>	100/600	—
½ x 3½	<b>57856</b>	25	▲		—
½ x 4	<b>57864</b>	25	<b>57864J</b>	25/150	—
½ x 4½	<b>57872</b>	25	▲		—
½ x 5	<b>57880</b>	25	▲		—
½ x 5½	<b>57888</b>	25	▲		—
½ x 6	<b>57896</b>	25	▲		—

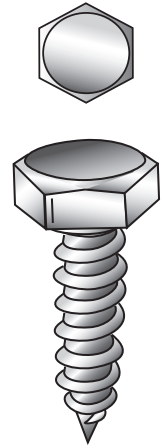

▲ Contact customer service for gravity feed jar availability.

For bulk packaging, contact customer service for quantities and availability.

**FASTENERS • BOLTS**

## CARRIAGE BOLTS • ZINC PLATED

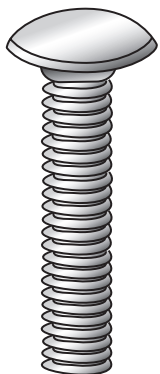

FASTENERS • BOLTS

Size			Best Merchandising Option			
	Cardboard Box		Gravity Feed Jar		Job Jar	
	Part #	Box Qty	Part #	Jar Qty/ Std Pk	Part #	Jar Qty
1/4-20 x 3/4	55112	100	▲			—
1/4-20 x 1	55116	100	▲			—
1/4-20 x 1 1/4	55120	100	▲			—
1/4-20 x 1 1/2	55124	100	▲			—
1/4-20 x 2	55132	100	▲			—
1/4-20 x 2 1/2	55140	100	▲			—
1/4-20 x 3	55148	100	▲			—
1/4-20 x 3 1/2	55156	100	▲			—
1/4-20 x 4	55164	100	▲			—
5/16-18 x 3/4	55312	100	▲			—
5/16-18 x 1	55316	100	▲			—
5/16-18 x 1 1/4	55320	100	▲			—
5/16-18 x 1 1/2	55324	100	▲			—
5/16-18 x 2	55332	100	▲			—
5/16-18 x 2 1/2	55340	100	▲			—
5/16-18 x 3	55348	100	▲			—
5/16-18 x 3 1/2	55356	50	▲			—
5/16-18 x 4	55364	50	▲			—
3/8-16 x 3/4	55512	100	▲			—
3/8-16 x 1	55516	100	▲			—
3/8-16 x 1 1/4	55520	100	▲			—
3/8-16 x 1 1/2	55524	100	▲			—
3/8-16 x 2	55532	100	▲			—
3/8-16 x 2 1/2	55540	50	55540J	50/300		—
3/8-16 x 3	55548	50	▲			—
3/8-16 x 3 1/2	55556	50	▲			—
3/8-16 x 4	55564	50	▲			—

▲ Contact customer service for gravity feed jar availability.

For bulk packaging, contact customer service for quantities and availability.

## GRADE 2 FULLY THREADED MACHINE TAP BOLTS • ZINC

Size	Cardboard Box		Best Merchandising Option		Job Jar	
	Part #	Qty	Part #	Jar Qty/ Std Pk	Part #	Jar Qty
¼-20 x 1¼	55022	100	55022J	100/600	—	—
¼-20 x 1½	55026	100	55026J	100/600	—	—
¼-20 x 2	55034	100	▲		—	—
¼-20 x 2½	55035	100	▲		—	—
¼-20 x 3	55050	100	▲		—	—
⅝-18 x 1	55216	100	▲		—	—
⅝-18 x 1½	55227	100	▲		—	—
⅝-18 x 2	55234	100	▲		—	—
⅝-18 x 2½	55242	100	▲		—	—
⅜-16 x 1¼	55422	100	55422J	100/600	—	—
⅜-16 x 2	55434	50	▲		—	—
⅜-16 x 2½	55442	50	▲		—	—
⅜-16 x 3	55450	50	▲		—	—
½-13 x 1	55816	50	▲		—	—
½-13 x 1¼	55822	50	55822J	50/300	—	—
½-13 x 1½	55826	50	▲		—	—
½-13 x 2	55834	50	▲		—	—
½-13 x 2½	55842	50	▲		—	—
½-13 x 3	55850	50	▲		—	—

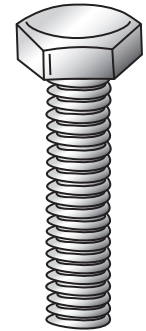

FASTENERS • BOLTS

▲ Contact customer service for gravity feed jar availability.

For bulk packaging, contact customer service for quantities and availability.

## GRADE 2 HEX HEAD MACHINE BOLTS • ZINC

- 1", ¾" and ½" are fully threaded.
- No markings and made of low grade carbon steel.

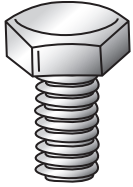

▲ Contact customer service for gravity feed jar availability.

For bulk packaging, contact customer service for quantities and availability.

FASTENERS • BOLTS

Size	Cardboard Box		Best Merchandising Option		Job Jar	
	Part #	Qty	Part #	Jar Qty/Std Pk	Part #	Jar Qty
¼-20 x ½	55008	100	55008J	100/1200	—	—
¼-20 x ¾	55012	100	55012J	100/600	—	—
¼-20 x 1	55016	100	55016J	100/600	—	—
¼-20 x 1¼	55020	100	55020J	100/600	—	—
¼-20 x 1½	55024	100	55024J	100/600	—	—
¼-20 x 2	55032	100	55032J	100/600	—	—
¼-20 x 2½	55040	100	55040J	100/600	—	—
¼-20 x 3	55048	100	55048J	100/600	—	—
¼-20 x 3½	55056	50	▲	—	—	—
¼-20 x 4	55064	50	▲	—	—	—
5/16-18 x ½	55208	100	▲	—	—	—
5/16-18 x ¾	55212	100	55212J	100/600	—	—
5/16-18 x 1	55216	100	55216J	100/600	—	—
5/16-18 x 1¼	55220	100	55220J	100/600	—	—
5/16-18 x 1½	55224	100	55224J	100/600	—	—
5/16-18 x 2	55232	100	▲	—	—	—
5/16-18 x 2½	55240	100	55240J	100/600	—	—
5/16-18 x 3	55248	100	55248J	100/600	—	—
5/16-18 x 3½	55256	50	▲	—	—	—
5/16-18 x 4	55264	50	▲	—	—	—
¾-16 x ½	55408	100	55408J	100/600	—	—
¾-16 x ¾	55412	100	55412J	100/600	—	—
¾-16 x 1	55416	100	55416J	100/600	—	—
¾-16 x 1¼	55420	100	55420J	100/600	—	—
¾-16 x 1½	55424	100	55424J	100/600	—	—
¾-16 x 2	55432	50	55432J	100/600	—	—
¾-16 x 2½	55440	50	55440J	50/300	—	—
¾-16 x 3	55448	50	55448J	50/300	—	—
¾-16 x 3½	55456	50	55456J	50/300	—	—
¾-16 x 4	55464	50	55464J	50/300	—	—
½-13 x ¾	55812	50	55812J	50/300	—	—
½-13 x 1	55816	50	55816J	50/300	—	—
½-13 x 1¼	55820	50	55820J	50/300	—	—
½-13 x 1½	55824	50	55824J	50/300	—	—
½-13 x 2	55832	50	55832J	50/300	—	—
½-13 x 2½	55840	50	55840J	50/300	—	—
½-13 x 3	55848	50	55848J	50/300	—	—
½-13 x 3½	55856	25	55856J	25/150	—	—
½-13 x 4	55864	25	55864J	25/150	—	—

## GRADE 5 HEX CAP SCREWS • ZINC

- Has three hash marks and made of medium carbon steel—quenched and tempered.
- See Grade 5 Hex Head Nuts on page 59.
- Fully threaded.

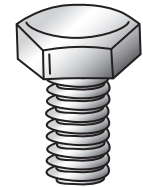

**FASTENERS • BOLTS**

				Best Merchandising Option		
				Gravity Feed Jar		
				USA		Jar Qty/ Std Pk
Size	Part #	USA Part #	Qty	Part #	USA Part #	
1/4-20 x 1/2	55009	55009US ★	100	55009J	55009USJ ★	100/600
1/4-20 x 3/4	55013	55013US ★	100	55013J	55013USJ ★	100/600
1/4-20 x 1	55017	55017US ★	100	55017J	55017USJ ★	100/600
1/4-20 x 1 1/4	55021	55021US ★	100	55021J	55021USJ ★	100/600
1/4-20 x 1 1/2	55025	55025US ★	100	55025J	55025USJ ★	100/600
1/4-20 x 2	55033	55033US ★	100	55033J	55033USJ ★	100/600
1/4-20 x 2 1/2	55041	55041US ★	100	55041J	55041USJ ★	100/600
1/4-20 x 3	55049	55049US ★	100	55049J	55049USJ ★	100/600
5/16-18 x 1/2	55209	55209US ★	100	55209J	55209USJ ★	100/600
5/16-18 x 3/4	55213	55213US ★	100	55213J	55213USJ ★	100/600
5/16-18 x 1	55217	55217US ★	100	55217J	55217USJ ★	100/600
5/16-18 x 1 1/4	55221	55221US ★	100	55221J	55221USJ ★	100/600
5/16-18 x 1 1/2	55225	55225US ★	100	55225J	55225USJ ★	100/600
5/16-18 x 2	55233	55233US ★	100	55233J	55233USJ ★	100/600
5/16-18 x 2 1/2	55241	55241US ★	100	55241J	55241USJ ★	100/600
3/8-16 x 1/2	55409	55409US ★	100	55409J	55409USJ ★	100/600
3/8-16 x 3/4	55413	55413US ★	100	55413J	55413USJ ★	100/600
3/8-16 x 1	55417	55417US ★	100	55417J	55417USJ ★	100/600
3/8-16 x 1 1/4	55421	55421US ★	100	55421J	55421USJ ★	100/600
3/8-16 x 1 1/2	55425	55425US ★	100	55425J	55425USJ ★	100/600
3/8-16 x 2	55433	55433US ★	50	55433J	55433USJ ★	100/600
3/8-16 x 2 1/2	55441	55441US ★	50	55441J	55441USJ ★	100/600
3/8-16 x 3	55449	55449US ★	50	55449J	55449USJ ★	100/600
1/2-13 x 3/4	55813	55813US ★	50	55813J	55813USJ ★	100/600
1/2-13 x 1	55817	55817US ★	50	55817J	55817USJ ★	100/600
1/2-13 x 1 1/4	55821	55821US ★	50	55821J	55821USJ ★	100/600
1/2-13 x 1 1/2	55825	55825US ★	50	55825J	55825USJ ★	100/600
1/2-13 x 2	55833	55833US ★	50	55833J	55833USJ ★	100/600
1/2-13 x 2 1/2	55841	55841US ★	50	55841J	55841USJ ★	100/600
1/2-13 x 3	55849	55849US ★	50	55849J	▲	100/600

▲ Contact customer service for gravity feed jar availability.

★ Made in USA

For bulk packaging, contact customer service for quantities and availability.

### STOVE BOLTS • ROUND HEAD MACHINE SCREW WITH HEX NUTS • ZINC

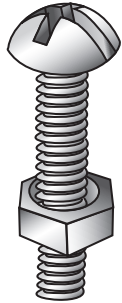



FASTENERS • BOLTS

Size	Cardboard Box		Best Merchandising Option		Job Jar	
	Part #	Qty	Part #	Jar Qty/ Std Pk	Part #	Jar Qty
¼-20 x ½	25508	100	25508J	100/600	—	—
¼-20 x ¾	25512	100	25512J	100/600	—	—
¼-20 x 1	25516	100	25516J	100/600	—	—
¼-20 x 1¼	25520	100	25520J	100/600	—	—
¼-20 x 1½	25524	100	25524J	100/600	—	—
¼-20 x 2	25532	100	25532J	100/600	—	—
¼-20 x 2½	25540	100	▲	—	—	—
¼-20 x 3	25548	100	▲	—	—	—
¾-16 x 1	25716	100	25716J	100/600	—	—
¾-16 x 1¼	25720	100	▲	—	—	—
¾-16 x 1½	25724	100	▲	—	—	—
¾-16 x 2	25732	100	▲	—	—	—

▲ Contact customer service for gravity feed jar availability.

Kits			
Part #	Description		
	<b>10-24 (¾) Stove Bolt Kit</b>		
39539 (440 Piece Kit)	10-24 x ½" (60 Pieces)	10-24 x 1" (40 Pieces)	10-24 x 1½" (20 Pieces)
	10-24 x ¾" (50 Pieces)	10-24 x 1¼" (30 Pieces)	10-24 x 2" (20 Pieces)
	10-24 Hex Nut (220 Pieces)		
	<b>¼-20 Stove Bolt Kit</b>		
39540 (220 Piece Kit)	¼-20 x ½" (30 Pieces)	¼-20 x 1" (20 Pieces)	¼-20 x 1½" (10 Pieces)
	¼-20 x ¾" (25 Pieces)	¼-20 x 1¼" (15 Pieces)	¼-20 x 2" (10 Pieces)
	¼-20 Hex Nut (110 Pieces)		

### EYE BOLTS WITH HEX NUTS • ZINC

						Best Merchandising Option			
						 Cardboard Box	 Gravity Feed Jar		
Size	Overall Length	Thread Size	Thread Length	Shank Length	Inside Eye Diameter	Part #	Box Qty	Part #	Jar Qty/Std Pk
3/16	1 1/2	10-24	25/32	7/8	3/8	<b>64024</b>	100	▲	
	2	10-24	1	1 3/8	3/8	<b>64032</b>	50	▲	
	2 1/4	10-24	1 5/8	1 3/4	3/8	<b>64040</b>	50	▲	
	3	10-24	2 1/8	2 1/4	3/8	<b>64048</b>	50	▲	
1/4	2	1/4-20	7/8	1	9/16	<b>64132</b>	30	<b>64132J</b>	100/600
	2 1/2	1/4-20	1 3/8	1 1/2	9/16	<b>64140</b>	30	<b>64140J</b>	100/600
	3	1/4-20	1 3/4	2	9/16	<b>64148</b>	30	<b>64148J</b>	100/600
	4	1/4-20	2 3/4	3	9/16	<b>64164</b>	30	<b>64164J</b>	50/300
	5	1/4-20	3	4	9/16	<b>64180</b>	30	<b>64180J</b>	50/300
5/16	3 1/4	5/16-18	1 3/4	2	3/4	<b>64252</b>	20	▲	
	4	5/16-18	2 1/4	2 1/2	3/4	<b>64264</b>	20	▲	
	5	5/16-18	3	3 1/2	3/4	<b>64280</b>	20	▲	
3/8	4	3/8-16	2	2 1/4	1	<b>64364</b>	20	<b>64364J</b>	50/300
	5	3/8-16	3	3 1/4	1	<b>64380</b>	20	<b>64380J</b>	25/150
	6	3/8-16	4	4 1/4	1	<b>64396</b>	20	<b>64396J</b>	25/150
	8	3/8-16	4	6 1/4	1	<b>64399</b>	20	▲	
1/2	6	1/2-13	3	3 3/4	1 1/4	<b>64496</b>	10	▲	
	8	1/2-13	3	5 3/4	1 1/4	<b>64499</b>	10	▲	
	10	1/2-13	3	7 3/4	1 1/4	<b>64510</b>	10	▲	
	12	1/2-13	3	9 3/4	1 1/4	<b>64512</b>	10	▲	

▲ Contact customer service for gravity feed jar availability.

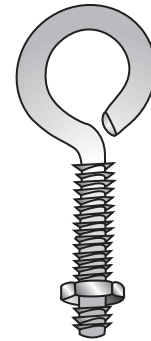

FASTENERS • BOLTS

### U-BOLTS • ZINC • NUTS & PLATES INCLUDED

Fits Pipe Size	Height	Width Between Legs	Thread Length	Thread Size	Part #	Qty
2	5	2 3/8	3	5/16-18	<b>67005</b>	1
2	7	2 3/8	3	5/16-18	<b>67007</b>	1
2	9	2 3/8	3	5/16-18	<b>67009</b>	1



### ACOUSTICAL WEDGE ANCHORS • OVERHEAD SUSPENSIONS



- Used to hang lighting fixtures and drop ceilings from concrete.
- Great for concrete and other solid materials.
- Sets when load is applied.

See Tie Wire on page 108.

		Best Merchandising Option					
		Cardboard Box		Gravity Feed Jar		Job Jar	
Size	Bit Size	Part #	Box Qty	Part #	Jar Qty/Std Pk	Part #	Jar Qty
¼ x 2¼	1⅝	62029	100	62029J	100/600	—	—

### SLEEVE ANCHORS • MEDIUM DUTY • CINDERBLOCK & BRICK



- Can be used in brick, cinder block, thin wall, as well as solid concrete.
- Can be removed after installation (unlike wedge anchor).
- Use same drill size as bolt diameter.

#### Installation

1. Use a solid carbide tipped bit. Drill the hole perpendicular to the work surface. Drill the hole as deep as the full length of the anchor.
3. Insert anchor through the fixture and into the hole until nut and washer rest against the fixture, or tap into the hole and then place bracket over the anchor.

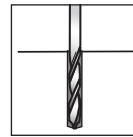

2. Clean the hole using compressed air and wire brush.

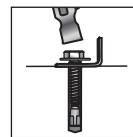

4. Tighten the nut with a torque wrench to the proper torque.



		Best Merchandising Option					
		Cardboard Box		Gravity Feed Jar		Job Jar	
Size	Drill Style	Part #	Box Qty	Part #	Jar Qty/Std Pk	Part #	Jar Qty
¼ x 1⅜	Acorn	61413	100	61413J	100/600	—	—
¼ x 2¼	Acorn	61422	100	▲	—	—	—
⅜ x 1⅝	Hex	61617	50	61617J	50/300	—	—
⅜ x 3	Hex	61630	50	61630J	100/600	—	—
⅜ x 4	Hex	61640	50	61640J	50/300	—	—
½ x 2¼	Hex	61822	25	61822J	25/150	—	—
½ x 3	Hex	61830	25	61830J	25/150	—	—
½ x 4	Hex	61840	25	▲	—	—	—

▲ Contact customer service for gravity feed jar availability.



## STRIKE SET ANCHORS • SOLID CONCRETE

- ICBO# 5045
- Easier, faster installation.

### Installation

1. Drill hole to minimum depth and diameter.
2. Clean the hole with pressurized air.
3. Set nut and washer for proper installment.
4. Drive center pin flush with top of anchor.

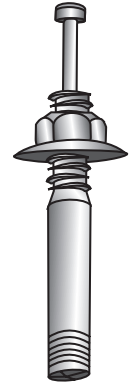

Size	Cardboard Box		10 Packs		Best Merchandising Option Job Jar	
	Part #	Box Qty	Part #	Box Qty	Part #	Jar Qty
1/4 x 1 3/4	63028	100	63029	10	▲	
1/4 x 2 3/8	63038	100	63039	10	▲	
5/16 x 2	63132	100	—		▲	
5/16 x 2 3/4	63144	100	—		▲	
3/8 x 2 3/8	63238	100	63239	10	▲	
3/8 x 3 1/2	63256	100	63257	10	▲	
3/8 x 4 3/4	63276	100	—		▲	
1/2 x 2 3/4	63444	50	—		▲	
1/2 x 3 1/2	63456	50	—		▲	
1/2 x 4 3/4	63476	50	—		▲	
1/2 x 6	63496	50	—		▲	
5/8 x 4	63664	30	—		▲	
5/8 x 4 3/4	63676	25	—		▲	
5/8 x 6	63696	25	—		▲	
3/4 x 7 1/2	63898	10	—		▲	



▲ Contact customer service for gravity feed jar availability.

### DOUBLE DRYWALL ANCHOR



- Works when penetrating wood stud behind drywall.
- No pre-drilling required.
- Quick and easy installation using a #2 Phillips.
- Up to 75lb load capacity when using 5/8" drywall.
- Easily removable.
- Not recommended for overhead use.



		Best Merchandising Option		
		 Kits	 Gravity Feed Jar	 Job Jar
Description		Part #	Part #	Part #
<b>Double Drywall Anchor Phillips</b>				
#8 x 1¼ (50 Pieces)		<b>39940</b>	<b>39940J</b>	<b>39940-6</b>
#2 Phillips Driver Bit (1 Piece)		(51 Piece Kit)	(51 Piece Kit)	(101 Piece Kit)



### ZAMAC "HAMMER DRIVE" NAIL-IN ANCHORS



- Economical choice for solid concrete, solid brick or block.
- Best suited for light-duty applications.
- Not recommended for vibrating loads or overhead installations.
- Requires no layout or hold spotting.
- 1,300 lb ultimate pullout (reference value).  
Use ¼ as safe working load (325#).

#### Installation

1. Drill hole ¼" deeper than required, blow hole clean of debris.
2. Insert anchor through fixture and hammer pin.

		Best Merchandising Option					
		 Cardboard Box	 Gravity Feed Jar	 Job Jar			
Size	Bit Size	Part #	Box Qty	Part #	Jar Qty/ Std Pk	Part #	Jar Qty
3/16 x 7/8	5/8	<b>59011</b>	100	<b>59011J</b>	100/600	—	—
1/4 x 3/4	5/8	<b>59012</b>	100	<b>59012J</b>	100/600	—	—
1/4 x 1	3/4	<b>59016</b>	100	<b>59016J</b>	100/600	<b>59016-6</b>	200
1/4 x 1¼	1	<b>59020</b>	100	<b>59020J</b>	100/600	<b>59020-6</b>	150
1/4 x 1½	1¼	<b>59024</b>	100	<b>59024J</b>	100/600	—	—
1/4 x 2	1½	<b>59032</b>	100	<b>59032J</b>	100/600	—	—

## NYLON NAIL-IN ANCHORS • LIGHT DUTY • REMOVABLE

- Removable version of Zamac Nail-In anchors.
- Often selected for bathroom applications (white finish).
- Light-duty applications only.
- 285 lb ultimate pull out (reference value). Use ¼ as safe work load (71#).

### Installation

1. Drill hole ¼" deeper than required, blow hole clean of debris.
2. Insert anchor through fixture and hammer pin.

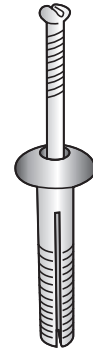

		Best Merchandising Option					
		Cardboard Box		Gravity Feed Jar		Job Jar	
Size	Drill Size	Part #	Box Qty	Part #	Jar Qty/ Std Pk	Part #	Jar Qty
¼ x 1	Mushroom	<b>61218</b>	100	<b>61218J</b>	100/600	—	—
¼ x 1½	Mushroom	<b>61226</b>	100	<b>61226J</b>	100/600	—	—
¼ x 2	Mushroom	<b>61232</b>	100	▲		—	—
¼ x 3	Mushroom	<b>61248</b> ★	100	▲		—	—

▲ Contact customer service for gravity feed jar availability.

★ Made in USA

For bulk packaging, contact customer service for quantities and availability.

FASTENERS • ANCHORS

## FLAT HEAD SPLIT BOLT ANCHORS • ZINC PLATED STEEL

- One piece “pre-expanded” anchor compresses as it is driven into base material.
- Very high shear values.
- Great for heavy-duty permanent installations.

		Best Merchandising Option					
		Cardboard Box		Gravity Feed Jar		Job Jar	
Size	Bit Size	Part #	Box Qty	Part #	Jar Qty/ Std Pk	Part #	Jar Qty
¼ x 1½	¼	<b>59124</b>	100	▲		—	—
¼ x 2	¼	<b>59132</b>	100	▲		—	—
¼ x 2½	¼	<b>59140</b>	100	▲		—	—
¼ x 3	¼	<b>59148</b>	100	▲		—	—
¼ x 3½	¼	<b>59156</b>	100	▲		—	—
¼ x 4	¼	<b>59164</b>	100	▲		—	—

▲ Contact customer service for gravity feed jar availability.



### TRUBOLT® WEDGE ANCHORS • HEAVY DUTY • CONCRETE & STONE • STAINLESS STEEL

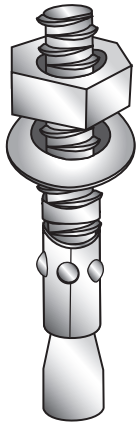

#### Installation

1) Select a carbide drill bit with a diameter equal to the anchor diameter. Drill hole to any depth exceeding the desired embedment.

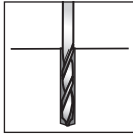

2) Clean hole or continue drilling additional depth to accommodate drill fines.



3) Assemble washer and nut, leaving nut flush with end of anchor to protect threads. Drive anchor through material to be fastened until washer is flush to surface of material.

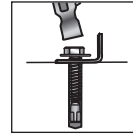

4) Expand anchor by tightening nut 3–5 turns past the hand tight position.

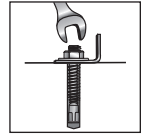

FASTENERS • ANCHORS

- Extremely high pull out value.
- Resistant to vibrating loads.

Size	Cardboard Box		Best Merchandising Option		Job Jar	
	Part #	Box Qty	Part #	Jar Qty/Std Pk	Part #	Jar Qty
¼ x 1¾	76528 ★ ♡	100	▲			—
¼ x 2¼	76536 ★ ♡	100	▲			—
¼ x 3¼	76552 ★ ♡	100	▲			—
⅜ x 2¼	76736 ★ ♡	50	▲			—
⅜ x 3	76748 ★ ♡	50	76748J ★	50/300		—
⅜ x 3¾	76760 ★ ♡	50	76760J ★	50/300		—
⅜ x 5	76780 ★ ♡	50	▲			—
½ x 2¾	76944 ★ ♡	25	▲			—
½ x 3¾	76960 ★ ♡	25	▲			—
½ x 4¼	76968 ★ ♡	25	▲			—
½ x 5½	76988 ★ ♡	25	▲			—
½ x 7	76998 ★ ♡	25	▲			—
⅝ x 3½	77156 ★ ♡	10	▲			—
⅝ x 4¼	77166 ★ ♡	10	▲			—
⅝ x 6	77196 ★ ♡	10	▲			—

★ Made in USA

♡ Harsh Environment Product

▲ Contact customer service for gravity feed jar availability.

#### Approvals/Listings

Trubolt® Wedge Anchors:

ICC Evaluation Service, Inc. # ESR-2251

- Category 1 performance rating
- 2006 IBC compliant
- Meets ACI 318 ductility requirements
- Tested in accordance with ACI 355.2 and ICC-ES AC193
- For use in seismic zones A & B
- ¼", ⅜" & ½" diameter anchors listed in ESR-2251

Underwriters Laboratories

Factory Mutual

City of Los Angeles - #RR2748

California State Fire Marshall

Caltrans

Meets or exceeds U.S. Government G.S.A. Specification A-A-1923A Type 4 (formerly GSA: FF-S-325 Group II, Type 4, Class 1)

## TRUBOLT® WEDGE ANCHORS • HEAVY DUTY • CONCRETE & STONE • ZINC

		Best Merchandising Option					
		Cardboard Box		Gravity Feed Jar		Job Jar	
Size	Min Embed	Part #	Box Qty	Part #	Jar Qty/ Std Pk	Part #	Jar Qty
¼ x 1¾	1⅞	62028 ★	100	62028J ★	100/600	—	—
¼ x 2¼	1⅞	62036 ★	100	62036J ★	100/600	—	—
¼ x 3¼	1⅞	62052 ★	100	62052J ★	50/300	—	—
⅜ x 2¼	1½	62236 ★	50	62236J ★	50/300	—	—
⅜ x 2¾	1½	62244 ★	50	62244J ★	50/300	—	—
⅜ x 3	1½	62248 ★	50	62248J ★	50/300	—	—
⅜ x 3¾	1½	62260 ★	50	62260J ★	50/300	—	—
⅜ x 5	1½	62280 ★	50	62280J ★	50/300	—	—
⅜ x 7	1½	62298 ★	50	▲	—	—	—
½ x 2¾	2¼	62444 ★	25	62444J ★	25/150	—	—
½ x 3¾	2¼	62460 ★	25	62460J ★	25/150	—	—
½ x 4¼	2¼	62468 ★	25	62468J ★	25/150	—	—
½ x 5½	2¼	62488 ★	25	▲	—	—	—
½ x 7	2¼	62498 ★	25	—	—	—	—
⅝ x 3½	2¾	62656 ★	10	▲	—	—	—
⅝ x 4¼	2¾	62672 ★	10	▲	—	—	—
⅝ x 5	2¾	62680 ★	10	▲	—	—	—
⅝ x 6	2¾	62696 ★	10	▲	—	—	—
⅝ x 8½	2¾	62700 ★	10	—	—	—	—
¾ x 4¾	3¼	62876 ★	10	▲	—	—	—
¾ x 5½	3¼	62888 ★	10	▲	—	—	—
¾ x 6¼	3¼	62897 ★	10	—	—	—	—
¾ x 7	3¼	62898 ★	10	—	—	—	—
¾ x 8½	3¼	62900 ★	10	—	—	—	—
¾ x 10	3¼	62910 ★	10	—	—	—	—

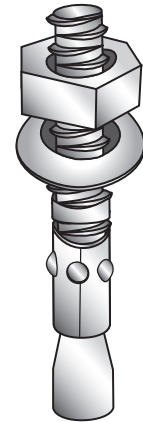

- See page 80 for installation instructions.
- Extremely high pull out value.
- Resistant to vibrating loads.

FASTENERS • ANCHORS

**Wedge Anchors are also called:**

- Red Heads
- Parabolts
- Kwikbolts
- Thunder Studs
- Stud Bolts

▲ Contact customer service for gravity feed jar availability.  
★ Made in USA

		10 Packs	
Size	Min Embed	Part #	Box Qty
¼ x 2¼	⅞	62037 ★	10
¼ x 3¼	⅞	62053 ★	10
⅜ x 2¼	1½	62237 ★	10
⅜ x 2¾	1½	62245 ★	10
⅜ x 3	1½	62249 ★	10

★ Made in USA

## LAG SCREW SHIELDS • MORTAR JOINT APPLICATIONS

FASTENERS • ANCHORS

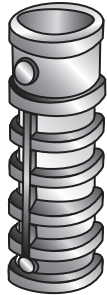

- Screw style anchor designed for lag bolts.
- Best used on mortar joints of block or brick walls.
- Short style preferred for harder masonry.

### Installation

1. Drill hole at least 1/2" deeper than minimum embedment.
2. Insert anchor into hole until it is flush with the surface.
3. Position fixture and insert lag bolt.
4. Tighten with wrench.

			Best Merchandising Option					
			Cardboard Box		Gravity Feed Jar		Job Jar	
Lag Screw Diameter	Length	Drill Diameter	Part #	Box Qty	Part #	Jar Qty/Std Pk	Part #	Jar Qty
1/4 S	1	1/2	60602	50	60602J	50/300	—	—
5/16 S	1 1/4	1/2	60606	50	60606J	50/300	—	—
3/8 S	1 3/4	5/8	60610	50	60610J	50/300	—	—
1/2 S	2	3/4	60614	25	▲		—	—
5/8 S	2	7/8	60618	25	▲		—	—
1/4 L	1 1/2	1/2	60604	50	▲		—	—
5/16 L	1 3/4	1/2	60608	50	▲		—	—
3/8 L	2 1/2	5/8	60612	50	60612J	50/300	—	—
1/2 L	3	3/4	60616	25	▲		—	—

▲ Contact customer service for gravity feed jar availability.

## LEAD SCREW ANCHORS • ACCEPTS SHEET METAL OR WOOD SCREWS

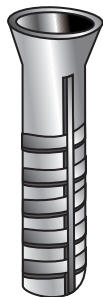

- Designed for use with sheet metal screws or wood screws in concrete, block or brick.
- 100% lead alloy composition molds itself to form tight bond.
- Recommended for light-duty applications.
- See instructions above

				Cardboard Box	
Lag Screw Diameter	Length	Drill Diameter	Min Depth	Part #	Box Qty
#6-8	3/4	1/4	3/4	60802	100
#6-8	1	1/4	1	60804	100
#6-8	1 1/2	1/4	1 1/2	60806	100
#10-12-14	3/4	5/16	3/4	60808	100
#10-12-14	1	5/16	1	60810	100
#10-12-14	1 1/2	5/16	1 1/2	60812	100
#16-18	1	3/8	1	60814	100
#16-18	1 1/2	3/8	1 1/2	60816	100

## STEEL DROP-IN ANCHORS

					Best Merchandising Option			
					Cardboard Box		Gravity Feed Jar	
Thread Size	Length	Thread Depth	Drill/Hole Diameter	Min Embed	Part #	Box Qty	Part #	Jar Qty/ Std Pk
¼-20	1	⅞	⅜	1	60402	100	60402J	100/600
⅜-16	1⅙	⅝	½	1⅝	60404	100	60404J	100/600
½-13	2	1⅜	⅝	2	60406	50	60406J	50/300
⅝-11	2½	1⅜	⅞	2½	60408	25	▲	
¾-10	3⅞	1⅜	1	3⅜	60410	25	▲	
⅝-16	Shallow Embedment Anchors		½	¾	60405	100	▲	



Setting Tool Included

- Use with machine screw, bolt or threaded rod.
- For use in solid concrete, hard stone and solid block.
- Internally threaded expansion anchor.
- **Requires layout or hole spotting.**

▲ Contact customer service for gravity feed jar availability.

Setting Tool		
Size	Part #	Qty
¼	60440	1
⅜	60444	1
½	60446	1
⅝	60448	1
¾	60450	1

### Installation

1. Use a masonry bit. Drill the hole to any depth slightly deeper than the anchor length.
2. Clean the hole using pressurized air.
3. Insert the anchor into the hole and hammer the anchor down until it is flush with the surface.
4. Expand the anchor by hitting the setting tool until the shoulder is flush with the anchor.

## LEAD MACHINE SCREW ANCHORS

			Best Merchandising Option					
			Cardboard Box		Gravity Feed Jar		Job Jar	
Thread Size	Drill/Hole Diameter	Min Embed	Part #	Box Qty	Part #	Jar Qty/ Std Pk	Part #	Jar Qty
10-24	⅜	⅝	60206	100	60206J	100/600	—	—
¼-20	½	⅞	60212	100	60212J	100/600	—	—
⅝-18	⅝	1	60214	100	60214J	100/600	—	—
⅜-16	¾	1¼	60216	50	60216J	50/300	—	—
½-13	⅞	1½	60218	50	60218J	50/300	—	—



Setting Tool Included

- Great for installation in older concrete where crumbling is a concern.
- Lead alloy molds itself to concrete surface for a tight fit.
- Zamac 7 internally threaded core.
- **Requires layout or hole spotting.**

Setting Tool		
Size	Part #	Qty
10-24	60236	1
¼	60240	1
⅝	60242	1
⅜	60244	1
½	60248	1

### Installation

1. Drill a hole equal to the nominal diameter of the anchor and deeper than the intended embedment.
2. Clean the hole using compressed air.
3. Insert anchor into the hole and drive expander shield over cone using a setting tool.
4. Position fixture, insert fastener and tighten.

### TOGGLER® SNAPTOGGLE® TOGGLE BOLT ANCHORS • HIGH STRENGTH



Toggles Only			Cardboard Box	
Model	Screw Size	Drill Size	Part #	Box Qty
BA	10-24 (3/16)	1/2	<b>58732</b> ★	100
BB	1/4-20 (1/4)	1/2	<b>58816</b> ★	100
BC	3/8-16	3/4	<b>58900</b> ★	25

★ Made in USA

Mini Kits		Clam Shell	
Screw Size	Drill Size	Part #	Box Qty
10-24 x 2 Th Sq/Slot	1/2	<b>58742</b> ★	6
10-24 x 3 Th Sq/Slot	1/2	<b>58743</b> ★	6
10-24 x 4 Th Sq/Slot	1/2	<b>58744</b> ★	6
1/4-20 x 3 Th Sq/Slot	1/2	<b>58817</b> ★	6
1/4-20 x 4 Th Sq/Slot	1/2	<b>58818</b> ★	6

#### Installation for Models BA & BB

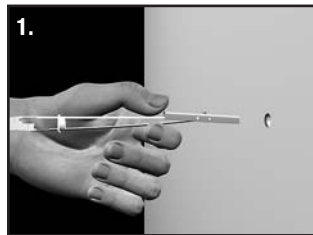

1. Drill 1/2" (Ø13mm) hole. Hold metal channel flat alongside plastic straps and slide channel through hole. Minimum clearance behind wall: 1 7/8" (48mm).

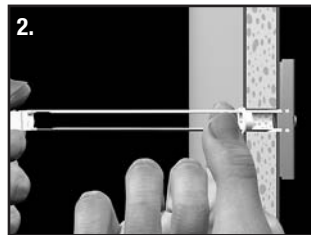

2. Hold ends of straps between thumb and forefinger and pull toward you until channel rests flush behind wall. Slide plastic cap along straps with other hand until flange of cap is flush with wall.

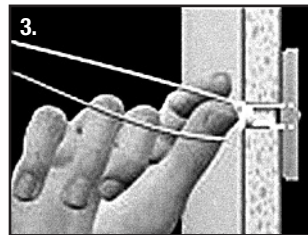

3. Snap straps at wall by pushing side to side, snapping off straps level with flange of cap.

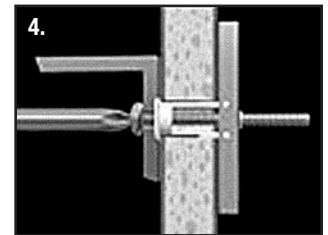

4. Place item over flange. Insert bolt through item and tighten until flush against item, then stop.

Use machine screw or bolt to match thread in channel: BA (3/16"-24), BB (1/4"-20).

Bolt length = item thickness + wall or ceiling thickness + 1/2" (13mm)

U.S. Patent No. 6,161,999 and foreign counterparts thereof and of 4,650,386. Other patents pending. TOGGLER and SNAPTOGGLE are worldwide registered trademarks of Mechanical Plastics Corp.

#### Ultimate Tensile Pull-Out Values (lb)

Anchor	UNC Thread	Drill Dia.	1/2" Drywall	5/8" Drywall	*1/2" and 25 Gauge Stud	*5/8" and 25 Gauge Stud	Concrete Block	1/2" Steel Plate	Stainless in 1/2" Steel <sup>3</sup>
<b>BA</b>	3/16"-24	1/2"	238	356	412	462	802	918 <sup>1</sup>	1193 <sup>1</sup>
<b>BB</b>	1/4"-20	1/2"	265	356	425	464	1080	1288 <sup>2</sup>	1735 <sup>1</sup>
<b>BE</b>	5/16"-18	3/4"	270	480	439	477	1400	1680	2118
<b>BC</b>	3/8"-16	3/4"	275	576	466	488	1745	1692	2523 <sup>1</sup>
<b>BD</b>	1/2"-13	3/4"	275	576	468	513	**2038 <sup>2</sup>	2605	3150

\* Failure measured as breakage of drywall portion

\*\* Failure of block

<sup>1</sup> Stainless steel bolts used

<sup>2</sup> Hardened bolts used

<sup>3</sup> Stainless steel channel tested with stainless bolts in 1/2" steel plate

#### Ultimate Shear (lb)

Anchor	UNC Thread	Drill Dia.	1/2" Drywall	5/8" Drywall
<b>BA</b>	3/16"-24	1/2"	247	298
<b>BB</b>	1/4"-20	1/2"	241	324
<b>BC</b>	3/8"-16	3/4"	292	406



## MUSHROOM HEAD TOGGLE BOLTS & WINGS • SLOTTED/SQUARE • ZINC • WINGS INCL.

		Best Merchandising Option					
		Cardboard Box		Gravity Feed Jar		Job Jar	
Screw Size	Drill/Hole Diameter	Part #	Box Qty	Part #	Jar Qty/Std Pk	Part #	Jar Qty
1/8 x 2	3/8	58132	100	58132J	100/600	—	—
1/8 x 3	3/8	58148	100	58148J	100/600	—	—
1/8 x 4	3/8	58164	100	▲		—	—
3/16 x 2	1/2	58332	100	▲		—	—
3/16 x 3	1/2	58348	50	58348J	50/300	—	—
3/16 x 4	1/2	58364	50	58364J	50/300	—	—
1/4 x 3	5/8	58548	50	58548J	50/300	—	—
1/4 x 4	5/8	58564	50	58564J	50/300	—	—

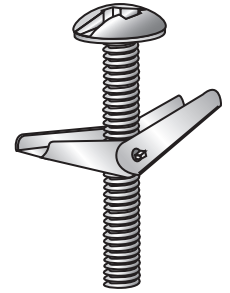

▲ Contact customer service for gravity feed jar availability.

## MUSHROOM HEAD TOGGLE BOLTS & WINGS • PHILLIPS/SLOTTED • ZINC • WINGS INCL.

		Best Merchandising Option					
		Cardboard Box		Gravity Feed Jar		Job Jar	
Screw Size	Drill/Hole Diameter	Part #	Box Qty	Part #	Jar Qty/Std Pk	Part #	Jar Qty
1/8 x 2	3/8	58133	100	58133J	100/600	—	—
1/8 x 3	3/8	58149	100	58149J	50/300	—	—
1/8 x 4	3/8	58165	100	58165J	50/300	—	—
3/16 x 2	1/2	58333	100	58333J	100/600	—	—
3/16 x 3	1/2	58349	50	58349J	50/300	—	—
3/16 x 4	1/2	58365	50	58365J	50/300	—	—
1/4 x 3	5/8	58549	50	58549J	50/300	—	—
1/4 x 4	5/8	58565	50	58565J	50/300	—	—

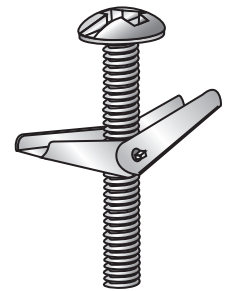

### ROUND HEAD TOGGLE BOLTS & WINGS • SLOTTED • ZINC • WINGS INCLUDED

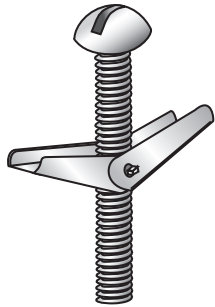

FASTENERS • ANCHORS

		Cardboard Box		Best Merchandising Option		Job Jar	
Screw Size	Drill/Hole Diameter	Part #	Box Qty	Part #	Jar Qty/Std Pk	Part #	Jar Qty
3/16 X 6	1/2	58396	50	58396J	50/300	—	—
1/4 X 6	5/8	58496	50	58496J	50/300	—	—
5/16 X 3	7/8	58647	50	▲		—	—
3/8 X 3	1	58648	50	58648J	25/150	—	—
3/8 X 4	1	58664	25	58664J	25/150	—	—
3/8 X 5	1	58680	25	▲		—	—
3/8 X 6	1	58696	25	58696J	25/150	—	—

### TOGGLE BOLT WINGS • SPRING LOADED • ZINC



		Cardboard Box		Best Merchandising Option		Job Jar	
Size	Part #	Box Qty	Part #	Jar Qty/Std Pk	Part #	Jar Qty	
1/8	58031	100	58031J	100/600	—	—	
3/16	58231	100	▲		—	—	
1/4-20	58431	100	58431J	100/600	—	—	
5/16-18	58531	100	▲		—	—	
3/8-16	58631	50	58631J	100/600	—	—	

▲ Contact customer service for gravity feed jar availability.

For bulk packaging, contact customer service for quantities and availability.

## TAPCON™ FLAT HEAD CONCRETE SCREWS • PHILLIPS

				Best Merchandising Option	
				Gravity Feed Jar	
Size	Drill	Part #	Box Qty	Part #	Jar Qty/Std Pk
3/16 x 1 1/4	5/32 x 3 1/2	<b>60520</b> ★	100	▲	
3/16 x 1 3/4	5/32 x 3 1/2	<b>60528</b> ★	100	▲	
3/16 x 2 1/4	5/32 x 4 1/2	<b>60536</b> ★	100	▲	
3/16 x 2 3/4	5/32 x 4 1/2	<b>60544</b> ★	100	▲	
3/16 x 3 1/4	5/32 x 5 1/2	<b>60552</b> ★	100	▲	
3/16 x 3 3/4	5/32 x 5 1/2	<b>60560</b> ★	100	▲	
3/16 x 4	5/32 x 5 1/2	<b>60564</b> ★	100	▲	
1/4 x 1 1/4	3/16 x 3 1/2	<b>60720</b> ★	100	▲	
1/4 x 1 3/4	3/16 x 3 1/2	<b>60728</b> ★	100	▲	
1/4 x 2 1/4	3/16 x 4 1/2	<b>60736</b> ★	100	<b>60736J</b>	100/600
1/4 x 2 3/4	3/16 x 4 1/2	<b>60744</b> ★	100	▲	
1/4 x 3 1/4	3/16 x 4 1/2	<b>60752</b> ★	100	▲	
1/4 x 4	3/16 x 5 1/2	<b>60764</b> ★	100	▲	

**FREE DRILL BIT IN EVERY PACK**

- ▲ Contact customer service for gravity feed jar availability.
- ★ Made in USA

For bulk packaging, contact customer service for quantities and availability.

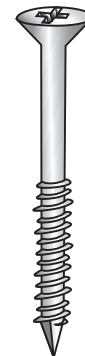

**FASTENERS • ANCHORS**

## TAPCON™ CARBIDE-TIPPED MASONRY DRILL BITS

### Installation

1. Drill a hole 1/2" deeper than the screw embedment.
2. Clean hole of all debris.
3. Insert the screw through the fixture and into the hole.
4. Drive the screw slowly, allowing the threads to tap into the base material.

Size	Part #	Box Qty/Std Pk
5/32 x 3 1/2	<b>61105</b> ★	1/10
5/32 x 4 1/2	<b>61107</b> ★	1/10
5/32 x 5 1/2	<b>61108</b> ★	1/10
3/16 x 3 1/2	<b>61109</b> ★	1/10
3/16 x 4 1/2	<b>61111</b> ★	1/10
3/16 x 5 1/2	<b>61113</b> ★	1/10

★ Made in USA



## TAPCON™ CONDRIVE INSTALLATION TOOL

- **ALL-IN-ONE** – The condrive sleeve with hex head and phillips socket snaps over the masonry drill bit for quick installations in concrete, block or brick.



Kits			
Part #	Description		
<b>61102</b> ★ (Tool Kit)	<b>Condrive 1000 Installation Tool</b>		
	1 Drill Driver	1 Phillips Bit Holder	2 Hex Driver
	1 Drill Adaptor	2 Phillips Bits	1 Allen Hex Key
	<b>Condrive 500 Installation Tool</b>		
<b>61103</b> ★ (Tool Kit)	1 Drill Driver	2 Phillips Bits	
	1 Drill Adaptor	1 Allen Hex Key	

★ Made in USA

### TAPCON™ CONCRETE SCREWS • HEX WASHER HEAD • SLOTTED

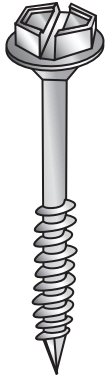

- Fast, easy installation in concrete, brick or block.
- Superior pullout and shear strengths.
- High-low thread design.
- ClimaSeal™ finish provides extended corrosion resistance.
- Tapcon™ is recommended for areas with soft concrete aggregate.

- ICC# 3320
- GSA 523
- MetroDade #90-1223
- NIS-64269

FASTENERS • ANCHORS

▲ Contact customer service for gravity feed jar availability.

For bulk packaging, contact customer service for quantities and availability.

		Cardboard Box		Best Merchandising Option	
				Gravity Feed Jar	
Size	Drill	Part #	Box Qty/Std Pk	Part #	Jar Qty/Std Pk
3/16 x 1 1/4	5/32 x 3 1/2	60120 ★	100	60120J ★	100/600
3/16 x 1 3/4	5/32 x 3 1/2	60128 ★	100	60128J ★	100/600
3/16 x 2 1/4	5/32 x 4 1/2	60136 ★	100	60136J ★	100/600
3/16 x 2 3/4	5/32 x 4 1/2	60144 ★	100	60144J ★	100/600
3/16 x 3 1/4	5/32 x 5 1/2	60152 ★	100	60152J ★	100/600
3/16 x 3 3/4	5/32 x 5 1/2	60160 ★	100	▲	
3/16 x 4	5/32 x 5 1/2	60164 ★	100	▲	
1/4 x 1 1/4	3/16 x 3 1/2	60320 ★	100	60320J ★	100/600
1/4 x 1 3/4	3/16 x 3 1/2	60328 ★	100	60328J ★	100/600
1/4 x 2 1/4	3/16 x 4 1/2	60336 ★	100	60336J ★	100/600
1/4 x 2 3/4	3/16 x 4 1/2	60344 ★	100	60344J ★	100/600
1/4 x 3 1/4	3/16 x 4 1/2	60352 ★	100	60352J ★	100/600
1/4 x 3 3/4	3/16 x 5 1/2	60360 ★	100	▲	
1/4 x 4	3/16 x 5 1/2	60364 ★	100	60364J ★	100/600

**FREE DRILL BIT IN EVERY PACK**

★ Made in USA

#### Condrite Installation Tool:

- Prevents overtightening.
- Eliminates need to remove and replace driver bits.
- See page 87.
- For additional Masonry/SDS Bits see pages 147-148.
- Fast changing simplifiers



Part #	Description		
62003 ★ (112 Piece Kit)	3/16" Diameter Tapcon™ Kit		
	1 1/4" (50 Piece)	1 3/4" (35 Piece)	2 1/4" (25 Piece)
	3 1/2" Bit (1)	4 1/2" Bit (1)	
62006 ★ (112 Piece Kit)	1/4" Diameter Tapcon™ Kit		
	1 1/4" (50 Piece)	1 3/4" (35 Piece)	2 1/4" (25 Piece)
	3 1/2" Bit (1)	4 1/2" Bit (1)	

★ Made in USA

## EZ TOGGLE™ ANCORS • ITW BUILDEX

- One-piece hollow wall anchor offers superior pullout and shear values.
- Great for overhead applications.
- No pre-drilling required.

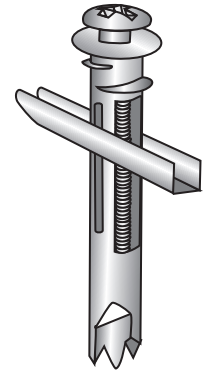

Description	Best Merchandising Option					
	Cardboard Box	Gravity Feed Jar	Job Jar			
	Part #	Box Qty	Part #	Jar Qty/ Std Pk	Part #	Jar Qty
EZ Toggle™ w/2" Phillips	<b>59520</b>	50	<b>59520J</b>	50/300	—	—
EZ Toggle™ w/2" Sq/Phil	<b>59521</b>	50	▲		—	—

Description	Best Merchandising Option	
	Kits	Gravity Feed Jar
	Part #	Part #
<b>EZ Toggle™ w/2" Phillips</b>		
EZ Toggles™ (25 Pieces) 2" Screws (25 Pieces)	<b>39926</b> (50 Piece Kit)	<b>39926J</b> (50 Piece Kit)
<b>EZ Toggle™ w/2" Square/Phillips</b>		
EZ Toggles™ (25 Pieces) 2" Square/Phillips (25 Pieces)	<b>39927</b> (50 Piece Kit)	<b>39927J</b> (50 Piece Kit)

▲ Contact customer service for gravity feed jar availability.

## HOLLOW WALL ANCHORS • COMBO PHILLIPS/SLOTTED SCREW • ZINC

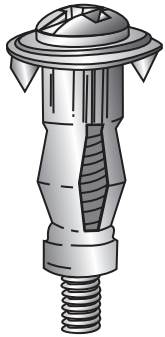

FASTENERS • ANCHORS

					Cardboard Box		Best Merchandising Option	
					Cardboard Box		Gravity Feed Jar	
Thread Size	Hex Length	Sleeve Length	Drill Size	Wall Thickness	Part #	Box Qty	Part #	Jar Qty/Std Pk
1/8	Extra Short	1 1/16	1/4	1/16-1/4	60002	100	▲	
1/8	Short	1 3/4	1/4	1/8-1/2	60004	100	60004J	100/600
1/8	Long	2 1/4	1/4	5/8-7/8	60006	100	▲	
1/8	Extra Long	2 11/16	1/4	1 1/4-1 1/2	60008	100	▲	
3/16	Short	2	3/8	1/8-5/8	60011	50	▲	
3/16	Long	2 1/2	3/8	5/8-1 3/16	60012	50	▲	
3/16	Extra Long	3	3/8	1 1/4-1 3/4	60014	50	▲	
1/4	Short	2 1/4	1/2	1/8-1/2	60016	50	60016J	100/600
1/4	Long	2 3/4	1/2	5/8-7/8	60018	50	60018J	100/600
1/4	Extra Long	3 3/8	1/2	1 1/4-1 3/4	60020	50	60020J	100/600
Hex Head	Hex Length	Sleeve Length	Drill Size	Wall Thickness	Part #	Box Qty	Part #	Jar Qty/Std Pk
1/8	Short	1 3/4	1/4	5/8-7/8	60022	100	▲	
1/8	Long	2 1/4	1/4	1/8-1 3/16	60024	100	▲	

## HOLLOW WALL ANCHORS • PHILLIPS/SLOTTED SCREWS WITH DRIVE POINT



- Easy to install, requires no drilling.
- Screw can be removed as often as needed.

### Installation

1. Drive anchor with hammer until cap prongs are embedded in the wall.
2. Turn screw clockwise to tighten.

					Cardboard Box		Best Merchandising Option	
					Cardboard Box		Gravity Feed Jar	
Thread Size	Length	Sleeve Length	Drill Size	Wall Thickness	Part #	Box Qty	Part #	Jar Qty/Std Pk
1/8	SD	1 3/8	1/4	1/8-1/2	60026	100	60026J	100/600
1/8	LD	2	1/4	5/8-7/8	60028	100	▲	
1/8	SLD	2 3/8	1/4	1/8-1 3/16	60030	100	▲	

▲ Contact customer service for gravity feed jar availability.

## TOGGLER® PLASTIC TOGGLE ANCHORS

				Best Merchandising Option			
				Cardboard Box		Gravity Feed Jar	
Wall Thickness	Drill Size	Screw Diameter	Type	Part #	Box Qty	Part #	Jar Qty/Std Pk
1/8-1/4	5/16	#8	A	68006 ★	100	▲	
3/8-1/2	5/16	#8	B	68008 ★	100	▲	
5/8-3/4	5/16	#8	C	68010 ★	100	▲	
3/8-1/2	5/16	#8	Hook	68012 ★	100	▲	

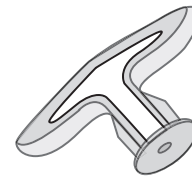

★ Made in USA

U.S. Patent Nos. 4,993,901 & 5,028,186 and foreign counterparts thereof and of 4,878,790. Other patents pending. TOGGLER is a worldwide registered trademark of Mechanical Plastics Corp.

## EZ ANCORS™ • #8 ZINC ALLOY • FULL SIZED

- A one-piece self-drilling anchor.

			Best Merchandising Option			
			Cardboard Box		Gravity Feed Jar	Job Jar
Size	Part #	Box Qty	Part #	Jar Qty/Std Pk	Part #	Jar Qty
#8 Zinc EZ Anchor <i>Screws not included.</i>	59510 ★	100	59510J ★	100/600	—	—

★ Made in USA

				Best Merchandising Option		
				Kits	Gravity Feed Jar	Job Jar
Description	Part #	Part #	Part #	Part #	Part #	Part #
<b>#8 EZ Anchor Sq/Phil Kit</b>						
EZ Ancors Zinc (50 Pieces)	39915 (101 Piece Kit)	39915J (101 Piece Kit)	39915-6 (201 Piece Kit)			
#8 x 1 1/4 Sq/Phil Screws (50 Pieces)						
#2-2" Hex Power Bit (1 Piece)						
<b>#8 EZ Anchor Phil/Slot Kit</b>						
EZ Ancors Zinc (50 Pieces)	39916 (101 Piece Kit)	39916J (101 Piece Kit)	39916-6 (201 Piece Kit)			
#8 x 1 1/4 Phil/Slot Screws (50 Pieces)						
#2-2" Hex Power Bit (1 Piece)						
<b>#8 EZ Anchor Slotted</b>						
8 x 1 1/4 HWH SMS Slotted Screw (50 Pieces)	39925 (101 Piece Kit)	▲				
E-Z Anchor Zinc-Plus (50 Pieces)						
#2-2 Phil Hex Bit (1 Piece)						

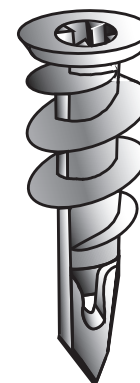

▲ Contact customer service for gravity feed jar availability.

For bulk packaging, contact customer service for quantities and availability.

### EZ ANCORS™ • #6-8 ZINC ALLOY • MINI

- A one-piece self-drilling anchor.

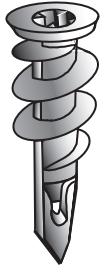

			Best Merchandising Option			
			Cardboard Box	Gravity Feed Jar	Job Jar	
Size	Part #	Box Qty	Part #	Jar Qty/Std Pk	Part #	Jar Qty
#6-8 Zinc EZ Mini Ancor <i>Screws not included.</i>	<b>59512</b> ★	100	<b>59512J</b> ★	100/600	—	

★ Made in USA

		Best Merchandising Option	
		Kits	Gravity Feed Jar
Description	Part #	Part #	
<b>EZ Mini Ancor Square/Phillips Kit</b>			
EZ Mini Ancors Zinc (50 Pieces)	<b>39928</b> (101 Piece Kit)	<b>39928J</b> (101 Piece Kit)	
#6 x 1" Sq/Phil Screws (50 Pieces)			
#2-2" Hex Power Bit (1 Piece)			
<b>EZ Mini Ancor Phillips/Slotted Kit</b>			
EZ Mini Ancors Zinc (50 Pieces)	<b>39929</b> (101 Piece Kit)	<b>39929J</b> (101 Piece Kit)	
#6 x 1" Phil/Slot Screws (50 Pieces)			
#2-2" Hex Power Bit (1 Piece)			
<b>EZ Mini Ancor Phillips Fine Thread</b>			
EZ Mini Ancors Zinc (50 Pieces)	<b>39932</b> (101 Piece Kit)	▲	
#6 x 1" Phillips Fine Thread Drywall Screws (50 Pieces)			
#2-2" Hex Power Bit (1 Piece)			

▲ Contact customer service for gravity feed jar availability.

For bulk packaging, contact customer service for quantities and availability.

FASTENERS • ANCHORS

### EZ ANCOR™ TRIPLE PACK • EZ ANCORS, EZ LITE & EZ TOGGLE

- A one-piece self-drilling anchor.

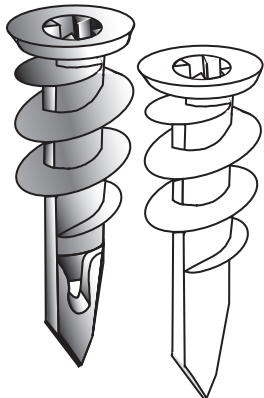

		Kits
Part #	Description	
<b>39930</b> (131 Pc Kit)	<b>EZ Triple Pack Sq/Phil Combo</b>	
	35 EZ Ancors Lites w/35 Screws	
	10 EZ Toggles w/10 Screws	
	20 Zinc EZ Ancors w/20 Screws	
		#2-2" Hex Power Bit

		Kits
Part #	Description	
<b>39931</b> (131 Pc Kit)	<b>EZ Triple Pack Slot/Phil Combo</b>	
	35 EZ Ancors Lites w/35 Screws	
	10 EZ Toggles w/10 Screws	
	20 Zinc EZ Ancors w/20 Screws	
		#2-2" Hex Power Bit

**Get the Assortment You Need with the Triple Pack!**



## EZ ANCORS™ #8 WHITE PLASTIC • FULL SIZED

		Best Merchandising Option		
		Cardboard Box	Gravity Feed Jar	Job Jar
Size	Part #	Box Qty	Part #	Jar Qty/ Std Pk
#8 Plastic EZ Ancor <i>Screws not included.</i>	<b>59515</b> ★	100	<b>59515J</b> ★	100/600

★ Made in USA

		Best Merchandising Option		
		Kits	Gravity Feed Jar	Job Jar
Size	Part #	Part #	Part #	Part #
<b>#8 EZ Ancor Sq/Phil Kit</b>				
Plastic EZ Ancors Zinc (50 Pieces)	<b>39920</b> ★	<b>39920J</b> ★	<b>39920-6</b> ★	
#8 x 1" Sq/Phil Screws (50 Pieces)	(101 Piece Kit)	(101 Piece Kit)	(201 Piece Kit)	
#2-2" Hex Power Bit (1 Piece)				
<b>#8 EZ Ancor Slot/Phil Kit</b>				
Plastic EZ Ancors Zinc (50 Pieces)	<b>39921</b> ★	<b>39921J</b> ★	<b>39921-6</b> ★	
#8 x 1" Slot/Phil Screws (50 Pieces)	(101 Piece Kit)	(101 Piece Kit)	(201 Piece Kit)	
#2-2" Hex Power Bit (1 Piece)				

★ Made in USA

## EZ ANCORS™ #6 WHITE PLASTIC LITE • LITE

• A one-piece self-drilling anchor.

		Best Merchandising Option		
		Cardboard Box	Gravity Feed Jar	Job Jar
Size	Part #	Box Qty	Part #	Jar Qty/ Std Pk
#6 Plastic Lite EZ Ancor <i>Screws not included.</i>	<b>59522</b> ★	100	<b>59522J</b> ★	100/600

★ Made in USA

		Best Merchandising Option	
		Kits	Gravity Feed Jar
Description	Part #	Part #	Part #
<b>#6 EZ Ancor Sq/Phil Kit</b>			
Plastic EZ Ancors Zinc (50 Pieces)	<b>39922</b>	<b>39922J</b>	
#6 x 1" Sq/Phil Screws (50 Pieces)	(101 Piece Kit)	(101 Piece Kit)	
#1-2" Hex Power Bit (1 Piece)			
<b>#6 EZ Ancor Slot/Phil Kit</b>			
Plastic EZ Ancors Zinc (50 Pieces)	<b>39923</b>	<b>39923J</b>	
#6 x 1" Slot/Phil Screws (50 Pieces)	(101 Piece Kit)	(101 Piece Kit)	
#1-2" Hex Power Bit (1 Piece)			



• A one-piece self-drilling anchor.



For bulk packaging, contact customer service for quantities and availability.

## SnapSkru™ SP™ by TOGGLER® SELF-DRILLING DRYWALL ANCHORS

FASTENERS • ANCHORS



SnapSkru™ SP™ self-drilling drywall anchor locks on the wall.

- Self-drilling – no pre-drilled hole required.
- The anchors accept a wide range of screw sizes: #6, #8, and #10.
- Anchors “pop” open and lock positively on the rear of the wall to resist vibration and shock in walls and in ceilings.

- Installs with a screwdriver or screw gun.
- Unique tip prevents “walking” to ensure accurate and easy drilling.
- The unique, positive-stop built into the head of the anchor resists overturning and drive-through.
- Can remove screw and item, leaving anchor in wall for reuse.

### Holding Power

- 1/2" Drywall holds 79 lbs
- 5/8" Drywall holds 135 lbs

### RATED FOR OVERHEAD APPLICATIONS!

### Applications

Securely hang bathroom accessories, mirrors, picture frames, lighting fixtures, drapery, smoke detectors, alarms, thermostats, electric boxes, shelving...

### Installation

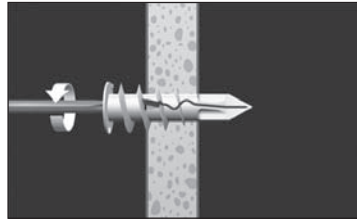

1. Drive anchor clockwise into drywall until anchor stops flush with the wall.

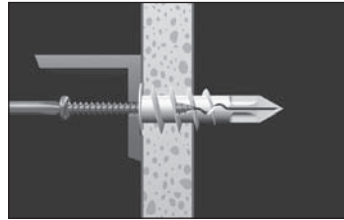

2. Place item over anchor and insert screw.

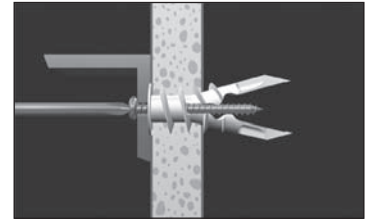

3. Tighten screw flush with item. Screw “pops” open anchor, locking anchor on wall.

		Best Merchandising Option
		Gravity Feed Jar
Description	Kits Part #	Part #
<b>#8 SnapSkru™ Kit</b>		
SnapSkru™ Anchors (40 Pieces)	<b>39933</b>	<b>39933J</b>
#8 x 1 1/2" Slot/Phil Screws (40 Pieces)	(80 Piece Kit)	(80 Piece Kit)

U.S. Patent Nos. 7,144,212 & 7,320,569 and foreign counterparts thereof. Other patents pending. TOGGLER and SnapSkru are worldwide registered trademarks of Mechanical Plastics Corp.

## TOGGLER® ALLIGATOR® SOLID & HOLLOW WALL ANCHORS • PLASTIC

- Highly versatile plastic anchor molds to wall for a tight fit.

### Application:

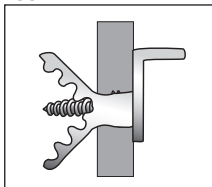

### Great for use in:

- Cinder Block
- Concrete
- Masonry
- Stucco
- Drywall
- Brick
- Ceramic Tile
- Particle Board

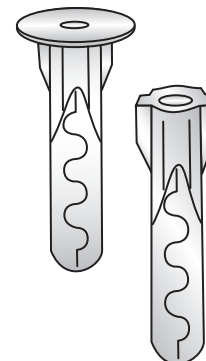

			Best Merchandising Option				
			Plastic Box	Gravity Feed Jar	Job Jar		
Description	Alligator #	Drill Size	Part #	Box Qty/Std Pk	Part #	Jar Qty/Std Pk	Part # Jar Qty
#8-10 with Flange	AF5	3/16"	59411 ★	100/500	▲		—
#10-12 with Flange	AF6	1/4"	59416 ★	50/250	59416J ★	50/300	—
#12-14 with Flange	AF8	5/16"	59417 ★	*100	▲		—
#8-10 without Flange	A6	1/4"	59418 ★	100/500	▲		—

★ Made in USA

▲ Contact customer service for gravity feed jar availability.

\*These items are packaged in cardboard boxes.

### Kits

#### #8-10 Alligator w/Square Drive Screws

Includes 3/16" Carbide Bit

**39412** #8-10 Alligators (AF5) (50 Pieces)  
(101 Pc Kit) #8 x 1 1/4" Sq Dr Screws (50 Pieces)

#### #8-10 Alligator w/Hex Washer Head Screws

Includes 3/16" Carbide Bit

**39414** #8-10 Alligators (AF5) (50 Pieces)  
(101 Pc Kit) #8 x 1 1/4" HWH Screws (50 Pieces)

#### #8-10 Alligator w/Slot/Phil Combo Screws

Includes 3/16" Carbide Bit

**39411** #8-10 Alligators (AF5) (50 Pieces)  
(101 Pc Kit) #8 x 1 1/4" Combo Dr Screws (50 Pieces)

#### #10-12 Alligator w/Square Drive Screws

Includes 1/4" Carbide Bit

**39415** #10-12 Alligators (AF6) (50 Pieces)  
(101 Pc Kit) #10 x 1 1/4" Sq Dr Screws (50 Pieces)

#### #10-12 Alligator w/Hex Washer Head Screws

Includes 1/4" Carbide Bit

**39417** #10-12 Alligators (AF6) (50 Pieces)  
(101 Pc Kit) #10 x 1 1/4" HWH Screws (50 Pieces)

### Kits

#### #10-12 Alligator w/Slot/Phil Combo Screws

Includes 1/4" Carbide Bit

**39422** #10-12 Alligators (AF6) (50 Pieces)  
(101 Pc Kit) #10 x 1 1/4" Combo Dr Screws (50 Pieces)

#### #12-14 Alligator w/Square Drive Screws

Includes 5/16" Carbide Bit

**39418** #12-14 Alligators (AF8) (50 Pieces)  
(101 Pc Kit) #12 x 1 1/2" Sq Drive Screws (50 Pieces)

#### #12-14 Alligator w/Hex Washer Head Screws

Includes 5/16" Carbide Bit

**39420** #12-14 Alligators (AF8) (50 Pieces)  
(101 Pc Kit) #12 x 1 1/2" HWH Screws (50 Pieces)

#### #12-14 Alligator w/Slot/Phil Combo Screws

Includes 5/16" Carbide Bit

**39421** #12-14 Alligators (AF8) (50 Pieces)  
(101 Pc Kit) #12 x 1 1/2" Combo Dr Screws (50 Pieces)

For bulk packaging, contact customer service for quantities and availability.

*U.S. Patent Nos. 5,161,296 & 5,938,385 and foreign counterparts thereof and of 4,752,170. Other patents pending. TOGGLER and SnapSkru are worldwide registered trademarks of Mechanical Plastics Corp.*

## GREEN PLUG ANCHORS

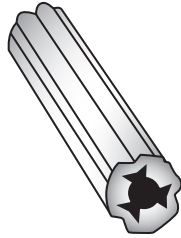

Description	Plastic Box		Gravity Feed Jar		Job Jar	
	Part #	Qty	Part #	Jar Qty/Std Pk	Part #	Jar Qty
#10-12 Green Plug Anchor	59425 ★	100	59425J ★	100/600	—	—
#8-10-12 Green Plastic Anchor	59450 ★	100	▲		—	—

★ Made in USA



Part #	Description
<b>39914</b> (201 Piece Kit)	<b>#10-12 Green Plug Anchor with Hex Washer Head Screws</b> #10 x 1" HWH Screws (100 Pieces) #10-12 Green Plug Anchor (100 Pieces) ¼" Carbide Bit

FASTENERS • ANCHORS

## PAN HEAD WALL DOG ANCHORS

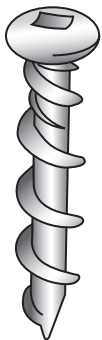
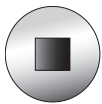

Size	Drive	Description	Plastic Box		Gravity Feed Jar		Job Jar	
			Part #	Qty	Part #	Jar Qty/Std Pk	Part #	Jar Qty
1¼	Phillips	Zinc	59504	100	59504J	100/600	—	—
1¼	Phillips	White	59505	100	59505J	100/600	—	—
1¼	Square	Zinc	59506	100	59506J	100/600	—	—
1¼	Hex Washer Head Combo	Zinc	59507	100	59507J	100/600	—	—

▲ Contact customer service for gravity feed jar availability.

For bulk packaging, contact customer service for quantities and availability.

## RED PLASTIC CONICAL ANCHORS

### Installation

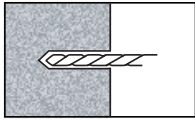

1. Drill proper size hole, ¼" deeper than anchor length.

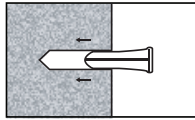

2. Insert anchor flush with surface of wall.

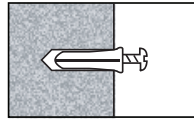

3. Insert wood or sheet metal screw through fixture and tighten.

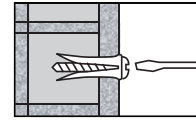

4. Anchor expands as wood or sheet metal screw is driven in.

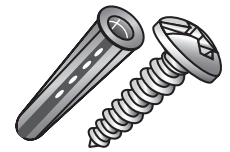

		Best Merchandising Option					
		Plastic Box	Gravity Feed Jar	Job Jar			
Description	Drill Size	Part #	Box Qty/ Std Pk	Part #	Jar Qty/ Std Pk	Part #	Jar Qty
#6-8 Red Conical	⅛	59408 ★	100/500	59408J ★	100/600	—	—
#8-10 Red Conical	⅜	59410 ★	100/500	59410J ★	100/600	—	—
#10-12 Red Conical	¼	59412 ★	100/500	59412J ★	100/600	—	—
#14-16 Red Conical	⅝	59414 ★	*100	▲		—	—

All plastic anchor Jars include a masonry drill bit.

\*These items are packaged in cardboard boxes!

★ Made in USA

		Best Merchandising Option		
		Kits	Gravity Feed Jar	Job Jar
Description	Part #	Part #	Part #	Part #
<b>#6 Slot/Phil Pan Head Red Conical Anchor Kit</b> Includes ⅛" Carbide Bit				
#6 x 1" Screws (100 Pieces)	39816	39816J		—
#6-8 Anchors (100 Pieces)	(201 Piece Kit)	(201 Piece Kit)		—
<b>#8 Square Drive Pan Head Red Conical Anchor Kit</b> Includes ⅜" Carbide Bit				
#8 x 1" Screws (100 Pieces)	39708	▲		—
#8-10 Anchors (100 Pieces)	(201 Piece Kit)			—
<b>#8 Slot/Phil Pan Head Red Conical Anchor Kit</b> Includes ⅜" Carbide Bit				
#8 x 1" Screws (100 Pieces)	39818	39819		—
#8-10 Anchors (100 Pieces)	(201 Piece Kit)	(201 Piece Kit)		—
<b>#8 Hex Washer Head Red Conical Anchor Kit</b> Includes ⅜" Carbide Bit				
#8 x 1" Screws (100 Pieces)	39908	▲		—
#8-10 Anchors (100 Pieces)	(201 Piece Kit)			—

Continued on next page.

▲ Contact customer service for gravity feed jar availability.

For bulk packaging, contact customer service for quantities and availability.

## RED PLASTIC CONICAL ANCHORS (CONT.)

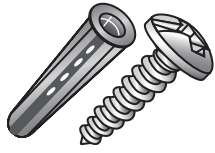

FASTENERS • ANCHORS

Description	Kits Part #	Best Merchandising Option	
		Gravity Feed Jar Part #	Job Jar Part #
<b>#10 Square Drive Pan Head Red Conical Anchor Kit</b> Includes 1/4" Carbide Bit			
#10 x 1" Screws (100 Pieces)	<b>39710</b> (201 Piece Kit)	<b>39711</b> (201 Piece Kit)	<b>39710-6</b> (401 Piece Kit)
#10-12 Anchors (100 Pieces)			
<b>#10 Slot/Phil Pan Head Red Conical Anchor Kit</b> Includes 1/4" Carbide Bit			
#10 x 1" Screws (100 Pieces)	<b>39820</b> (201 Piece Kit)	<b>39821</b> (201 Piece Kit)	<b>39820-6</b> (401 Piece Kit)
#10-12 Anchors (100 Pieces)			
<b>#10 Hex Washer Head Red Conical Anchor Kit</b> Includes 1/4" Carbide Bit			
#10 x 1" Screws (100 Pieces)	<b>39910</b> (201 Piece Kit)	<b>39911</b> (201 Piece Kit)	<b>39910-6</b> (401 Piece Kit)
#10-12 Anchors (100 Pieces)			
<b>#12 Slot/Phil Pan Head Red Conical Anchor Kit</b> Includes 1/4" Carbide Bit			
#12 x 1" Screws (100 Pieces)	<b>39822</b> (201 Piece Kit)	<b>39822J</b> (201 Piece Kit)	—
#10-12 Anchors (100 Pieces)			
<b>#12 Hex Washer Head Red Conical Anchor Kit</b> Includes 1/4" Carbide Bit			
#12 x 1" Screws (100 Pieces)	<b>39912</b> (201 Piece Kit)	▲	—
#10-12 Anchors (100 Pieces)			
<b>#12 Square Drive Pan Head Red Conical Anchor Kit</b> Includes 1/4" Carbide Bit			
#12 x 1" Screws (100 Pieces)	<b>39712</b> (201 Piece Kit)	▲	—
#10-12 Anchors (100 Pieces)			

▲ Contact customer service for gravity feed jar availability.

For bulk packaging, contact customer service for quantities and availability.

## YELLOW WINGED ANCHORS • PLASTIC

		Best Merchandising Option					
		Plastic Box	Gravity Feed Jar	Job Jar			
Description	Drill Size	Part #	Box Qty/ Std Pk	Part #	Jar Qty/ Std Pk	Part #	Jar Qty
#4-6-8 Yellow Vinyl	3/16	<b>59431</b> ★	100/500	<b>59431J</b> ★	100/600	—	—
#8-10-12 Yellow Vinyl	1/4	<b>59432</b> ★	50/250	<b>59432J</b> ★	100/600	—	—
#12-14-16 Yellow Vinyl	5/16	<b>59433</b> ★	*100	▲		—	—

★ Made in USA

		Best Merchandising Option		
		Kits	Gravity Feed Jar	Job Jar
Description	Part #	Part #	Part #	Part #
<b>#8 Square Drive Pan Head Yellow Winged Anchor Kit – Includes 3/16" Carbide Bit</b>				
#8 x 1" Screws (100 Pieces)	<b>39717</b>	<b>39718</b>	—	—
#4-6-8 Anchors (100 Pieces)	(201 Piece Kit)	(201 Piece Kit)		
<b>#8 Tek Washer Head Yellow Winged Anchor Kit – Includes 3/16" Carbide Bit</b>				
#8 x 1" Screws (100 Pieces)	<b>39747</b>	<b>39748</b>	—	—
#4-6-8 Anchors (100 Pieces)	(201 Piece Kit)	(201 Piece Kit)		
<b>#8 Slot/Phil Pan Head Yellow Winged Anchor Kit – Includes 3/16" Carbide Bit</b>				
#8 x 1" Screws (100 Pieces)	<b>39756</b>	<b>39759</b>	—	—
#4-6-8 Anchors (100 Pieces)	(201 Piece Kit)	(201 Piece Kit)		
<b>#10 Square Drive Pan Head Yellow Winged Anchor Kit – Includes 1/4" Carbide Bit</b>				
#10 x 1" Screws (100 Pieces)	<b>39721</b>	<b>39723</b>	<b>39723-6</b>	—
#8-10-12 Anchors (100 Pieces)	(201 Piece Kit)	(201 Piece Kit)	(201 Piece Kit)	
<b>#10 Hex Washer Head Yellow Winged Anchor Kit – Includes 1/4" Carbide Bit</b>				
#10 x 1" Screws (100 Pieces)	<b>39721</b>	<b>39723</b>	<b>39723-6</b>	—
#8-10-12 Anchors (100 Pieces)	(201 Piece Kit)	(201 Piece Kit)	(201 Piece Kit)	
<b>#10 Slot/Phil Pan Head Yellow Winged Anchor Kit – Includes 1/4" Carbide Bit</b>				
#10 x 1" Screws (100 Pieces)	<b>39761</b>	<b>39763</b>	<b>39763-6</b>	—
#8-10-12 Anchors (100 Pieces)	(201 Piece Kit)	(201 Piece Kit)	(201 Piece Kit)	
<b>#12 Square Drive Pan Head Yellow Winged Anchor Kit – Includes 5/16" Carbide Bit</b>				
#12 x 1 1/2" Screws (100 Pieces)	<b>39722</b>	<b>39724</b>	—	—
#12-14-16 Anchors (100 Pieces)	(201 Piece Kit)	(201 Piece Kit)		
<b>#12 Hex Washer Head Yellow Winged Anchor Kit – Includes 5/16" Carbide Bit</b>				
#12 x 1 1/2" Screws (100 Pieces)	<b>39752</b>	<b>39754</b>	—	—
#12-14-16 Anchors (100 Pieces)	(201 Piece Kit)	(201 Piece Kit)		
<b>#12 Slot/Phil Pan Head Yellow Winged Anchor Kit – Includes 5/16" Carbide Bit</b>				
#12 x 1 1/2" Screws (100 Pieces)	<b>39762</b>	<b>39764</b>	—	—
#12-14-16 Anchors (100 Pieces)	(201 Piece Kit)	(201 Piece Kit)		

▲ Contact customer service for gravity feed jar availability.

\* These items are packaged in cardboard boxes.

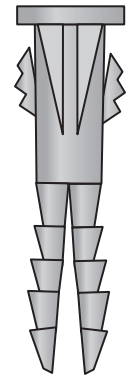

For bulk packaging, contact customer service for quantities and availability.

### EXPANDER ANCHORS • PLASTIC

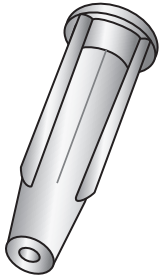

Description	Cardboard Box		Best Merchandising Option		Job Jar	
	Part #	Box Qty	Part #	Jar Qty/Std Pk	Part #	Jar Qty
#8-10 Expander Anchors	59440 ★	100	▲			—

▲ Contact customer service for gravity feed jar availability.

★ Made in USA

For bulk packaging, contact customer service for quantities and availability.

Description	Best Merchandising Option	
	Part #	Jar Qty/Std Pk
<b>#8 Square Drive Pan Head Expander Anchor Kit</b> Includes ¼" Carbide Bit		
#8 Expander Anchor (100 Pieces)	<b>39727</b>	(201 Piece Kit)
8 x 1½" Screws (100 Pieces)		
<b>#10 Square Drive Pan Head Expander Anchor Kit</b> Includes ¼" Carbide Bit		
#10 Expander Anchor (100 Pieces)	<b>39278</b>	(201 Piece Kit)
10 x 1½" Screws (100 Pieces)		
<b>#8 Hex Washer Head Expander Anchor Kit</b> Includes ¼" Carbide Bit		
#8 Expander Anchor (100 Pieces)	<b>39757</b>	(201 Piece Kit)
8 x 1½" Screws (100 Pieces)		
<b>#10 Hex Washer Head Expander Anchor Kit</b> Includes ¼" Carbide Bit		
#10 Expander Anchor (100 Pieces)	<b>39758</b>	(201 Piece Kit)
10 x 1½" Screws (100 Pieces)		
<b>#8 Phillips/Slotted Pan Head Expander Anchor Kit</b> Includes ¼" Carbide Bit		
#8 Expander Anchor (100 Pieces)	<b>39767</b>	(201 Piece Kit)
8 x 1½" Screws (100 Pieces)		
<b>#10 Phillips/Slotted Pan Head Expander Anchor Kit</b> Includes ¼" Carbide Bit		
#10 Expander Anchor (100 Pieces)	<b>39768</b>	(201 Piece Kit)
10 x 1½" Screws (100 Pieces)		



## HANGERBOLTS • ZINC

- Bolt with threaded areas at both ends, lag screw thread at one end and unified thread at the other.
- Standard hanger bolts insert into a predrilled pilot hole.
- The end of the wood thread tapers is threaded all the way to its blunt tip.



Best Merchandising Option						
Cardboard Box			Gravity Feed Jar		Job Jar	
Size	Part #	Box Qty	Part #	Jar Qty/Std Pk	Part #	Jar Qty
¼ x 1½	66124	100	66124J	100/600	—	—
¼ x 2	66132	100	66132J	100/600	—	—
¼ x 2½	66140	100	▲		—	—
¼ x 3	66148	100	66148J	100/600	—	—
¼ x 4	66164	100	▲		—	—
¾ x 2½	66340	100	▲		—	—
¾ x 3	66348	50	66348J	50/300	—	—
¾ x 3½	66356	50	▲		—	—
¾ x 4	66364	50	▲		—	—

▲ Contact customer service for gravity feed jar availability.

For bulk packaging, contact customer service for quantities and availability.

FASTENERS • HANGERS

## HANGERBOLT DRIVERS

- Driver has internal threads with an easy release ball bearing at the bottom to relax easily, saving time.

Plastic Bag		
Size	Part #	Qty
¼-20 x 2½	39101	1
⅝-18 x 2½	39102	1
¾-16 x 2½	39103	1



## SAMMYS® FOR WOOD • VERTICAL MOUNTING

### Application



Size	Model	Approvals	Rod Size	Nut Driver	Cardboard Box		Best Merchandising Option		Job Jar	
					Part #	Box Qty/Case Qty	Part #	Jar Qty/Std Pk	Part #	Jar Qty
¼ x 1	GST 100	—	¼	61192	<b>61144</b> ★	25/125	<b>61144J</b> ★	25/150	—	—
¼ x 2	GST 200	—	¼	61192	<b>61145</b> ★	25/125	<b>61145J</b> ★	25/150	—	—
¼ x 1	GST 10	UL	⅜	61192	<b>61147</b> ★	25/125	<b>61147J</b> ★	25/150	—	—
¼ x 2	GST 20	UL • FM	⅜	61192	<b>61148</b> ★	25/125	<b>61148J</b> ★	25/150	—	—
¼ x 3	GST 30	UL • FM	⅜	61192	<b>61150</b> ★	25/125	<b>61150J</b> ★	25/150	—	—
¼ x 2	GST 2	—	½	61193	<b>61152</b> ★	25/125	<b>61152J</b> ★	25/150	—	—
⅜ x 2½	GST25-380	UL • FM	⅜	61192	<b>61182</b> ★	25/125	<b>61182J</b> ★	25/150	—	—

★ Made in USA

### Nut Drivers



#61192 (Black) #61193 (Red)

FASTENERS • HANGERS

## SAMMYS® FOR WOOD • HORIZONTAL MOUNTING

### Application

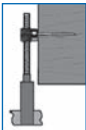

Size	Model	Approvals	Rod Size	Nut Driver	Cardboard Box		Best Merchandising Option		Job Jar	
					Part #	Box Qty/Case Qty	Part #	Jar Qty/Std Pk	Part #	Jar Qty
¼ x 1	SWG 100	—	¼	61193	<b>61154</b> ★	25/125	<b>61154J</b> ★	25/150	—	—
¼ x 2	SWG 200	—	¼	61193	<b>61155</b> ★	25/125	<b>61155J</b> ★	25/150	—	—
¼ x 1	SWG 10	UL	⅜	61193	<b>61156</b> ★	25/125	<b>61156J</b> ★	25/150	—	—
¼ x 2	SWG 20	UL	⅜	61193	<b>61157</b> ★	25/125	<b>61157J</b> ★	25/150	—	—
⅜ x 2½	SWG 25-380	UL	⅜	61193	<b>61183</b> ★	25/125	<b>61183J</b> ★	25/150	—	—

★ Made in USA

## SAMMYS® FOR STEEL • VERTICAL MOUNTING

					Best Merchandising Option					
					Cardboard Box	Gravity Feed Jar		Job Jar		
Size	Model	Approvals	Rod Size	Nut Driver	Part #	Box Qty/ Case Qty	Part #	Jar Qty/ Std Pk	Part #	Jar Qty
¼-20 x 1	DSTR 100	—	¼	61192	<b>61160</b> ★	25/125	<b>61160J</b> ★	25/150	—	—
¼-14 x 2	DST 200	—	¼	61192	<b>61162</b> ★	25/125	<b>61162J</b> ★	25/150	—	—
12-24 x 1½	TEK 500	—	¼	61192	<b>61163</b> ★	25/125	<b>61163J</b> ★	25/150	—	—
⅝-18 X 1¼	DSTR 516	UL • FM	⅜	61192	<b>61166</b> ★	25/125	<b>61166J</b> ★	25/150	—	—
12-24 x 1½	DSTR 1½	UL • FM	⅜	61192	<b>61168</b> ★	25/125	<b>61168J</b> ★	25/150	—	—
¼-20 x 1	DSTR 1	UL • FM	⅜	61192	<b>61169</b> ★	25/125	<b>61169J</b> ★	25/150	—	—
¼-14 x 1	DST 10	—	⅜	61192	<b>61170</b> ★	25/125	<b>61170J</b> ★	25/150	—	—
¼-14 x 2	DST 20	—	⅜	61192	<b>61172</b> ★	25/125	<b>61172J</b> ★	25/150	—	—
12-24 x 1½	TEK 50	UL • FM	⅜	61192	<b>61174</b> ★	25/125	<b>61174J</b> ★	25/150	—	—
¼-14 x 2	DST 2.0	—	½	61193	<b>61164</b> ★	25/125	<b>61164J</b> ★	25/150	—	—
¼-20 x 1	DSTR 1.0	—	½	61193	<b>61165</b> ★	25/125	<b>61165J</b> ★	25/150	—	—
12-24 x 1½	TEK 5.0	—	½	61193	<b>61167</b> ★	25/125	<b>61167J</b> ★	25/150	—	—

★ Made in USA

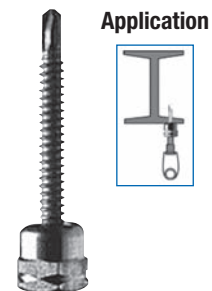

Application



Nut Drivers

#61192 (Black) #61193 (Red)

FASTENERS • HANGERS

## SAMMYS® FOR STEEL • HORIZONTAL MOUNTING

					Best Merchandising Option					
					Cardboard Box	Gravity Feed Jar		Job Jar		
Size	Model	Approvals	Rod Size	Nut Driver	Part #	Box Qty/ Case Qty	Part #	Jar Qty/ Std Pk	Part #	Jar Qty
¼-14 x 1	SWD 100	—	¼	61193	<b>61175</b> ★	25/125	<b>61175J</b> ★	25/150	—	—
¼-20 x 1	SWDR 100	—	¼	61193	<b>61176</b> ★	25/125	<b>61176J</b> ★	25/150	—	—
¼-14 x 1	SWD 10	—	⅜	61193	<b>61177</b> ★	25/125	<b>61177J</b> ★	25/150	—	—
¼-14 x 2	SWD 20	—	⅜	61193	<b>61179</b> ★	25/125	<b>61179J</b> ★	25/150	—	—
⅝-18 X 1¼	SWD 516	—	⅜	61193	<b>61180</b> ★	25/125	<b>61180J</b> ★	25/150	—	—
¼-20 x 1½	SWDR 1½	UL • FM	⅜	61193	<b>61181</b> ★	25/125	<b>61181J</b> ★	25/150	—	—

★ Made in USA



Application

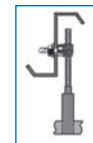

### SAMMYS® FOR CONCRETE • VERTICAL MOUNTING

#### Application



					Best Merchandising Option					
					Cardboard Box	Gravity Feed Jar		Job Jar		
Size	Model	Approvals	Rod Size	Nut Driver	Part #	Box Qty/ Case Qty	Part #	Jar Qty/ Std Pk	Part #	Jar Qty
5/16 x 1 3/4	CST 200	—	1/4	61192	<b>61185</b> ★	25/125	<b>61185J</b> ★	25/150	—	—
5/16 x 1 3/4	CST 20	FM	3/8	61192	<b>61186</b> ★	25/125	<b>61186J</b> ★	25/150	—	—
5/16 x 1 3/4	CST 2	—	1/2	61193	<b>61187</b> ★	25/125	<b>61187J</b> ★	25/150	—	—

★ Made in USA

### SAMMYS® FOR CONCRETE • HORIZONTAL MOUNTING

#### Application

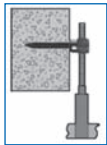

					Best Merchandising Option					
					Cardboard Box	Gravity Feed Jar		Job Jar		
Size	Model	Approvals	Rod Size	Nut Driver	Part #	Box Qty/ Case Qty	Part #	Jar Qty/ Std Pk	Part #	Jar Qty
5/16 x 1 3/4	SWC 200	FM	1/4	61193	<b>61189</b> ★	25/125	<b>61189J</b> ★	25/150	—	—
5/16 x 1 3/4	SWC 20	—	3/8	61193	<b>61188</b> ★	25/125	<b>61188J</b> ★	25/150	—	—

FASTENERS • HANGERS

#### Nut Drivers



**#61192**  
(Black)



**#61193**  
(Red)

#### Kits



Part #	Description		
<b>61190</b> ★	<b>Concrete Installation Kit</b>		
(7 Piece Kit)	#250 – Bit (1/4")	SDS 250 Bit (1/4")	7/32" Wood Bit
	Hex 250 – Bit Receiver (1/4")	#14 Nut Driver	#14 SW Nut Driver
	SL 250 – Sleeve		

★ Made in USA

### SAMMY® X-PRESS • USE WITH ¼" OR ⅜" ROD



Application



U.S. Patent  
No. 6,935,821

**Sammy X-Press**  
(for vertical attachment)



Application



**Sammy X-Press Sidewinder**  
(for horizontal attachment)  
#61202



- Pipe Hanger for X-Treme Roof Pitches.
  - 89° in purlin
  - 45° in metal deck for 12/12 pitch
- Installs in seconds, saves time and installation costs.
- Use in applications where easy access to the back of the installed faster is prohibited.
- No retaining nut required.



**Universal X-Press It®**  
**Installation Tool**  
#61200

							Best Merchandising Option			
							Cardboard Box		Gravity Feed Jar	
Description	Model	Rod Size	Max Pipe Size	Steel Gauge	Approvals	Application	Part #	Box Qty/ Case Qty	Part #	Jar Qty/ Std Pk
Sammy X-Press 20	XP 20	⅜-16	4	12	FM	Metal Deck	<b>61194</b> ★	25/125	<b>61194J</b> ★	25/150
Sammy X-Press 35	XP 35	⅜-16	4	12	FM	Purlin	<b>61197</b> ★	25/125	<b>61197J</b> ★	25/150
Sidewinder X-Press 35	SWXP 35	⅜-16	3½	16-12	UL	Purlin	<b>61202</b> ★	25/125	<b>61202J</b> ★	25/150
Swivel X-Press 20	SXP 20	⅜-16	2	22-20	UL	Metal Deck	<b>61203</b> ★	25/125	<b>61203J</b> ★	25/150
Swivel X-Press 35	SXP 35	⅜-16	3½	16-12	UL	Purlin	<b>61204</b> ★	25/125	<b>61204J</b> ★	25/150
Sammy X-Press 200	XP 200	¼-20	185 lbs*	—	UL	Metal Deck	<b>61198</b> ★	25/125	<b>61198J</b> ★	25/150
Universal X-Press It Tool	UXPIT	—	—	—	—	—	<b>61200</b> ★	1	▲	
Replacement Bit for 61200		—	—	—	—	—	<b>61201</b> ★	1	▲	
Retro Socket	RXPIT	—	—	—	—	—	<b>61195</b> ★	1	▲	

\*Load Rating.

★ Made in USA

## HANGERMATE® • METAL APPLICATIONS

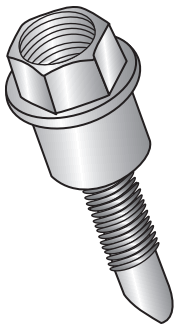

- Installs easily in metal up to 1/4" thick.
- Yellow dichromate finish provides outstanding corrosion protection.
- Requires no pre-drilling and is quick to install.

		Best Merchandising Option					
		Cardboard Box		Gravity Feed Jar		Job Jar	
Threaded Size	OAL	Part #	Box Qty	Part #	Jar Qty/Std Pk	Part #	Jar Qty
1/4-20	1 7/8	<b>59614</b> ★	50	<b>59614J</b> ★	50/300	—	—
3/8-16	1 7/8	<b>59616</b> ★	50	<b>59616J</b> ★	50/300	—	—

★ Made in USA

### Starter Kit

Part #	Description		
<b>59643</b> ★ (21 Piece Kit)	<b>Hangermate® Metal Drilling Kit</b>		
	1/4" Self-Drilling Anchors (10 Pieces)	3/8" Self-Drilling Anchors (10 Pieces)	3/8" Recessed Drive Socket (1 Piece)

★ Made in USA

FASTENERS • HANGERS

## HANGERMATE® • WOOD APPLICATIONS

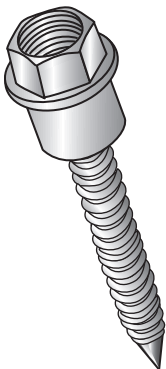

- Tapped to accept 1/4-20 and 3/8-16 threaded rod.
- Yellow dichromate finish for outstanding corrosion protection.
- Installs easily with insert socket.

		Best Merchandising Option					
		Cardboard Box		Gravity Feed Jar		Job Jar	
Threaded Size	OAL	Part #	Box Qty	Part #	Jar Qty/Std Pk	Part #	Jar Qty
1/4-20	2 1/2	<b>59615</b> ★	50	<b>59615J</b> ★	50/300	—	—
3/8-16	2 1/2	<b>59617</b> ★	50	<b>59617J</b> ★	50/300	—	—

★ Made in USA

### Starter Kit

Part #	Description		
<b>59645</b> ★ (21 Piece Kit)	<b>Hangermate® Wood Drilling Kit</b>		
	1/4" Wood-Drilling Anchors (10 Pieces)	3/8" Wood-Drilling Anchors (10 Pieces)	3/8" Recessed Drive Socket (1 Piece)

★ Made in USA

## HANGERMATE® BRUTES • SIDEMOUNT APPLICATIONS

- Tapped to accept 3/8"-16 threaded rod.
  - New sidemount configuration offers added convenience.
- Requirements:**
- Driver required. Order part #59620.

			Best Merchandising Option				
			Cardboard Box	Gravity Feed Jar	Job Jar		
Description	Application	OAL	Part #	Box Qty	Part #	Jar Qty/ Std Pk	Part # Jar Qty
3/8"-16 Brute Sidemount	Metal	2 3/4"	<b>59613</b> ★	50	<b>59613J</b> ★	50/300	—
3/8"-16 Brute Sidemount	Wood	2 3/4"	<b>59618</b> ★	50	▲		—

▲ Contact customer service for gravity feed jar availability. ★ Made in USA

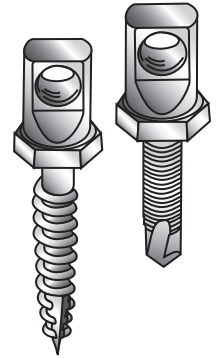

## HANGERMATE® INSTALLATION TOOLS

Description	Part #	Qty
Hangermate® Driver (ZE 215)	<b>59620</b> ★	1
SDS 0.234" Carbide Bit	<b>59635</b> ★	1
Masonry Install Tool (ZE 220)	<b>59640</b> ★	1
Tanged Bit Adaptor (ZE 240)	<b>59641</b> ★	1

★ Made in USA

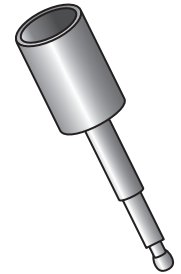

## THREADED ROD

Zinc		
Size	Part #	Tube Qty
1/4-20 x 3'	<b>59703</b>	50
3/8-16 x 3'	<b>59702</b>	25
1/4-20 x 6'	<b>59704</b>	50
5/16-18 x 6'	<b>59705</b>	35
3/8-16 x 6'	<b>59706</b>	25
1/2-13 x 6'	<b>59708</b>	12
5/8-11 x 6'	<b>59710</b>	5
1/4-20 x 10'	<b>59804</b>	50
5/16-18 x 10'	<b>59805</b>	35
3/8-16 x 10'	<b>59806</b>	25
1/2-13 x 10'	<b>59808</b>	12
5/8-11 x 10'	<b>59810</b>	5

Stainless Steel		
Size	Part #	Tube Qty
1/4-20 x 3'	<b>71931</b> ▽	50
5/16-18 x 3'	<b>71932</b> ▽	35
3/8-16 x 3'	<b>71933</b> ▽	25
1/2-13 x 3'	<b>71934</b> ▽	36
1/4-20 x 6'	<b>71961</b> ▽	50
5/16-18 x 6'	<b>71962</b> ▽	35
3/8-16 x 6'	<b>71963</b> ▽	25
1/2-13 x 6'	<b>71964</b> ▽	12
1/4-20 x 12'	<b>71921</b> ▽	50
5/16-18 x 12'	<b>71922</b> ▽	35
3/8-16 x 12'	<b>71923</b> ▽	25
1/2-13 x 12'	<b>71924</b> ▽	12

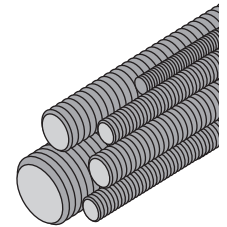

- When shipping an order including 10' lengths and over, minimum freight pre-pay is \$1,000.
- Rod is sold per piece, not per foot.

### Dimension All Thread Rod (ATR)

- Dimensions taken from ANSI B1.1-1982 Unified Inch Screw Threads.
- All threads are UNCR series.
- Tabulated loads are based on an allowable tensile stress of 12000 psi (82.7 MPa) reduced by 25% resulting in 9000 psi (62 MPa). From ANSI/MSS SP-58, Table 3.

Nominal Size & Thread	Root Area		Design Load (SF=5)	
	in. <sup>2</sup>	cm <sup>2</sup>	lbs	kN
1/4 - 20	0.027	0.174	240	1.07
5/16 - 18	0.045	0.290	400	1.78
3/8 - 16	0.068	0.438	610	2.71

▽ Harsh Environment Product

## HEX ROD & REDUCING COUPLINGS • ZINC

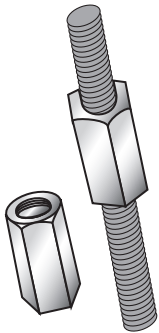

				Best Merchandising Option	
				Cardboard Box	Gravity Feed Jar
Size	Couplings	Part #	Box Qty	Part #	Jar Qty/ Std Pk
1/4-20 x 7/16 x 3/4	Hex Rod	<b>59604</b>	100	<b>59604J</b>	100/600
5/16-18	Hex Rod	<b>59605</b>	100	▲	
3/8-16	Hex Rod	<b>59606</b>	100	<b>59606J</b>	100/600
1/2-13	Hex Rod	<b>59608</b>	50	<b>59608J</b>	100/600
1/4-20 to 3/8-16	Reducing	<b>59625</b>	50	<b>59625J</b>	100/600
3/8-16 to 1/2-13	Reducing	<b>59626</b>	50	<b>59626J</b>	50/300

▲ Contact customer service for gravity feed jar availability.

For bulk packaging, contact customer service for quantities and availability.

FASTENERS • HANGERS

## TIE WIRE



				Cardboard Box	
Description	Gauge	Length	Weight (lbs)	Part #	Box Qty
Tie Wire (Steel Black Annealed Coil)	#16	340'	3½	<b>71000</b>	20 Coils
Tie Wire (Galvanized Coil)	#16-½	450'	4	<b>71001</b>	20 Coils
Ceiling Tie Wire (Galvanized Length)	#12	10'	—	<b>69950</b> ★	100 Pcs/Bundle

★ Made in USA



## JACK CHAIN • ZINC PLATED

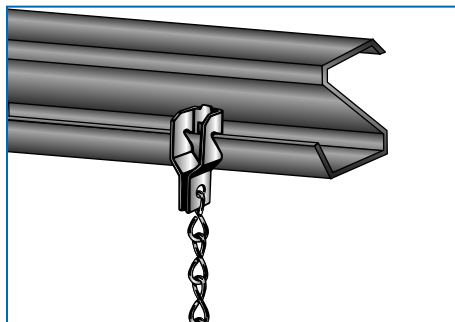

- For support of light fixtures and signs.
- Zinc plated steel.

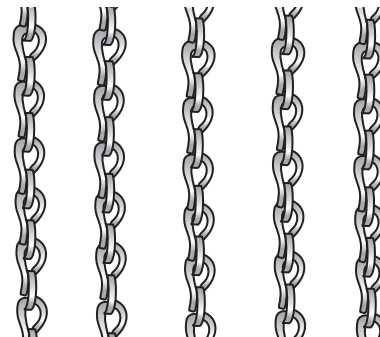

		Cardboard Box		Reel		Bucket	
Work Load Limit (lbs)	Gauge	Part #	Box Qty	Part #	Reel Qty	Part #	Bucket Qty
48	#10	<b>72011</b> ★	100'	<b>72010</b> ★	100'	<b>72018</b> ★	300'
29	#12	<b>72013</b> ★	100'	<b>72012</b> ★	100'	<b>72020</b> ★	300'
16	#14	<b>72015</b> ★	100'	<b>72014</b> ★	200'	—	—
11	#16	—	—	<b>72016</b> ★	250'	—	—

★ Made in USA

## JACK CHAIN • STAINLESS STEEL

		Cardboard Box	
Work Load Limit (lbs)	Gauge	Part #	Box Qty
43	#10	<b>72010SS</b> ★ ♡	100'
29	#12	<b>72012SS</b> ★ ♡	100'

★ Made in USA

♡ Harsh Environment Product

## DOUBLE LOOP TENSO CHAIN • ZINC PLATED

			Reel	
Work Load Limit (lbs)	Gauge	Size	Part #	Box Qty
255	#10	2/0	<b>74002</b> ★	175'
200	#10	1/0	<b>74010</b> ★	100'
155	#12	1	<b>74011</b> ★	200'
90	#14	3	<b>74013</b> ★	200'
90	#14	3	<b>74014</b> ★	100'

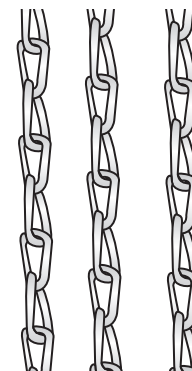

Sold by box/pkg (not by foot)

★ Made in USA

### PLUMBER'S TAPE (PERFORATED STRAP IRON) • GALVANIZED & COPPER

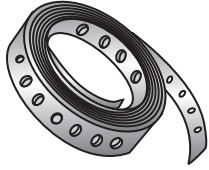

Gauge	Type	Width	Length	Part #	Unit	Std Pack
22	Galvanized	¾"	10'	<b>94422</b> ★	1	100 Rolls
24	Copper	¾"	10'	<b>94430</b> ★	1	100 Rolls
28	Galvanized	¾"	10'	<b>94428</b> ★	1	100 Rolls
26	Galvanized	¾"	10'	<b>94426</b> ★	1	100 Rolls

★ Made in USA

### S-HOOKS • ZINC



- For hanging Jack Chain to various overhead hangers.
- Made from pre-galvanized steel.

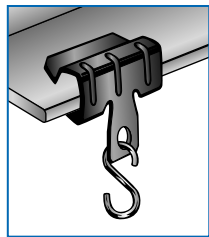

Size	Cardboard Box		Best Merchandising Option		Job Jar	
	Part #	Qty	Part #	Jar Qty/Std Pk	Part #	Jar Qty
¾"	<b>70012</b> ★	100	<b>70012J</b> ★	100/600	—	—
1"	<b>70016</b> ★	100	<b>70016J</b> ★	100/600	—	—
1¼"	<b>70020</b> ★	100	<b>70020J</b> ★	100/600	—	—
1½"	<b>70024</b> ★	100	<b>70024J</b> ★	100/600	—	—
2"	<b>70032</b> ★	50	<b>70032J</b> ★	100/600	—	—
2½"	<b>70040</b> ★	50	<b>70040J</b> ★	100/600	—	—
3"	<b>70048</b> ★	50	<b>70048J</b> ★	50/300	—	—

★ Made in USA

### V-HOOKS • FLUORESCENT FIXTURE HANGERS • ZINC



- For use with fluorescent lighting fixtures holding 2, 3 or 4 bulbs.

Side Mount		
Size	Part #	Qty
10 Gauge	<b>70000</b> ★	50

Top/End Mount		
Size	Part #	Qty
10 Gauge	<b>70002</b> ★	50

★ Made in USA

## KRYLON® INDUSTRIAL QUIK-MARK™ INVERTED MARKING PAINT



- Make a mark fast in all types of wind and weather.
- A heavy-duty industrial paint.
- Fast drying, high solids formula that penetrates and adheres to hot and cold surfaces.
- Features exclusive Spray-Thru™ cap and non-clogging spray tip.
- Available in APWA colors (American Public Works Association) and fluorescent colors.
- VOC-compliant and lead free.
- Solvent-Based paints are the best choice for cool or damp conditions.
- Water-Based paints are best suited for hot and dry conditions.
- See the Color Selection Guide on page 112.



**Know what's below.  
Call before you dig.**

### Uses:

- Ground Surveying
- Construction Marking
- Excavation
- Utility

Description	Base Type	MSDS REF #	Part #	Can Size	Net Fill	Std Pk
Fluorescent Safety Red	Water-Based	S03610	<b>37681</b> ★	20 oz	17 oz	12
Fluorescent Safety Green	Water-Based	S03630	<b>37459</b> ★	20 oz	17 oz	12
Fluorescent Orange	Water-Based	S03700	<b>37460</b> ★	20 oz	17 oz	12
Fluorescent Pink	Water-Based	S03612	<b>37655</b> ★	20 oz	17 oz	12
Brilliant White APWA	Water-Based	S03901	<b>37461</b> ★	20 oz	17 oz	12
Utility Yellow APWA	Water-Based	S03801	<b>37462</b> ★	20 oz	17 oz	12
Fluorescent Red/Orange	Water-Based	S03650	<b>37463</b> ★	20 oz	17 oz	12
Fluorescent Caution Blue	Water-Based	S03620	<b>37465</b> ★	20 oz	17 oz	12
Clear	Water-Based	S03500	<b>37466</b> ★	20 oz	17 oz	12
Red APWA	Solvent-Based	S03611	<b>37455</b> ★	20 oz	17 oz	12
Hi-Vis Yellow APWA	Solvent-Based	S03821	<b>37467</b> ★	20 oz	17 oz	12
Fluorescent Orange	Solvent-Based	S03702	<b>37468</b> ★	20 oz	17 oz	12
Utility White APWA	Solvent-Based	S03900	<b>37469</b> ★	20 oz	17 oz	12
Fluorescent Red/Orange	Solvent-Based	AT3701	<b>37470</b> ★	20 oz	17 oz	12
Blue APWA	Solvent-Based	S03621	<b>37471</b> ★	20 oz	17 oz	12
Green APWA	Solvent-Based	S03631	<b>37472</b> ★	20 oz	17 oz	12
Fluorescent Hot Pink	Solvent-Based	S03622	<b>37482</b> ★	20 oz	17 oz	12
Clear	Solvent-Based	S03600	<b>37647</b> ★	20 oz	17 oz	12

★ Made in USA

You can find access to all current MSDS sheets on the Krylon Products Group website.

[www.KPG-Industrial.com](http://www.KPG-Industrial.com)

### COLOR SELECTION GUIDE • INVERTED MARKING PAINT

Application	Color	Water-Based Cully Part #	Solvent-Based Cully Part #
Electric Power Lines, Cables, Conduit and Lighting Cables	Fluorescent Red/Orange	37463 ★	37470 ★
	Red APWA	37681 ★	37455 ★
Gas, Oil, Steam, Petroleum or Gaseous Materials	Utility Yellow APWA	37462 ★	—
Communication, Alarm or Signal Lines, Cables or Conduit	Fluorescent Orange	37460 ★	37468 ★
Potable Water	Fluorescent Caution Blue	37465 ★	—
	Blue APWA	—	37471 ★
Sewers and Drain Lines	Fluorescent Safety Green	37459 ★	—
	Green APWA	—	37472 ★
Temporary Survey Markings	Fluorescent Hot Pink	37655 ★	37482 ★
Proposed Excavation	Brilliant White APWA	37461 ★	—
	Utility White APWA	37469 ★	—
General Purpose and Chalk Line Extender	Clear	37466 ★	37647 ★
Roads, Highway Pavement	Hi-Visibility Yellow APWA	—	37467 ★

★ Made in USA

### PAINT ACCESSORIES

Description	Compatibility	MSDS Ref #	Part #	Unit
Wheeler Hand-Held Wand (34" Length)	Inverted Marking Paint (20 oz or 16 oz Cans)	K07096	37456 ★	1
Can Holster	Inverted Marking Paint (20 oz or 16 oz Cans)	K08000000	37457 ★	1
Snap & Spray™ Can Adapter	Aerosol Paint Cans	K07099	37458 ★	12

★ Made in USA

#### Marking Wand

37456 ★

- Constructed of durable, rugged plastic and lightweight steel.
- Comfortable pistol grip for easy handling and marking.
- Apply a uniform 1" to 1½" width of paint.
- Can Holster also available.

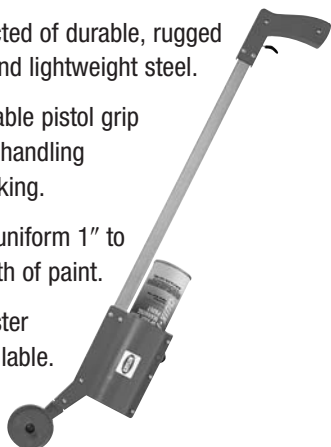

#### Can Holster

37457 ★

- Specially designed for holding inverted marking paint cans.
- Features rugged holster.
- Measures: 3½" diameter x 6½" high.



★ Made in USA

#### Can Adapter

37458 ★

- Transforms any standard spray can of paint, cleaner or lubricant into a spray gun.
- Snaps easily onto can rim.
- Eliminates finger fatigue.
- Trigger lock prevents accidental use.



## KRYLON® INDUSTRIAL TOUGH COAT® ACRYLIC ENAMEL PAINT

Description	MSDS Ref #	Part #	Can Size	Net Fill	Std Pk
OSHA Safety Green	S01470	<b>37473</b> ★	16 oz	12 oz	12
OSHA Black	S01770	<b>37474</b> ★	16 oz	12 oz	12
OSHA White	S01800	<b>37475</b> ★	16 oz	12 oz	12
OSHA Yellow	S01310	<b>37476</b> ★	16 oz	12 oz	12
Semi-Flat Black	S03725	<b>37477</b> ★	16 oz	12 oz	12
Max Flat Black	S03727	<b>37478</b> ★	16 oz	12 oz	12
OSHA Red	S01110	<b>37479</b> ★	16 oz	12 oz	12
OSHA Blue	S01510	<b>37480</b> ★	16 oz	12 oz	12
OSHA Orange	S01210	<b>37481</b> ★	16 oz	12 oz	12
Machinery Dark Gray (ASA-49)	S00325	<b>37485</b> ★	16 oz	12 oz	12
Medium Gray	S01615	<b>37486</b> ★	16 oz	12 oz	12
Industrial Gray	S01630	<b>37487</b> ★	16 oz	12 oz	12
Light Gray	S01645	<b>37488</b> ★	16 oz	12 oz	12
Blue/Gray	S01625	<b>37489</b> ★	16 oz	12 oz	12
Machinery Gray	S01620	<b>37490</b> ★	16 oz	12 oz	12
Machine Blue/Gray (ASA-24)	S00329	<b>37491</b> ★	16 oz	12 oz	12
Machinery Light Gray (ASA-61)	S00326	<b>37492</b> ★	16 oz	12 oz	12

★ Made in USA

- Features patented EZ Touch™ fan spray nozzle that requires 50% less finger pressure than most other paint valves.
- Ideal for light to heavy duty painting projects, both indoors and outdoors.
- Tough, protective coating resists chipping and peeling.
- Excellent hiding characteristics.
- Low odor and VOC-compliant
- Dries to the touch in 15 minutes.

### Uses:

- Metal
- Motors
- Tools
- Machinery
- Railings & Electrical Equipment



You can find access to all current MSDS sheets on the Krylon Products Group website.

[www.KPG-Industrial.com](http://www.KPG-Industrial.com)

## CONTACT CLEANER SELECTION GUIDE

### Chemical Properties

Product Description/ Part #	O.K. for These Substrates						Removes These Contaminants					Chemical Properties			
	Metals	Polycarb.	ABS	Nylon	Teflon	PVC	Light Oil	Flux	Solder	Rosin	Dust	Flash Point	Drying Time	Dielectric Strength	Plastic Safe
<b>Electro Wizard 37680</b>	X	X	X	X	X	X	B	A	A	A	B	None	Very Fast	12,500	Yes
<b>Plastics Contact Cleaner 37504</b>	X	X	X	X	X	X	B	C	—	C	B	None	Very Fast	19,000	Yes
<b>Environmental Contact Cleaner 37505</b>	X	X	X	X	X	X	A	A	A	A	A	None	Fast	N/A	Yes

A = Strong Cleaning Action

B = Good Cleaning Action

C = Moderate Cleaning Action

PAINT & CHEMICALS

**Is maximum solvency your main concern?**

Yes, and I need a high Dielectric Strength as well.

**Plastics  
Contact Cleaner**

**37504**

Yes, and I accept a lower Dielectric Strength if it costs less.

**3-2-1  
Contact Cleaner**

**37566**

**Do you require a non-chlorinated product?**

Yes, and I'm not concerned with flammability.

**Environmental  
Cleaner/Degreaser**

**37501**

**Are you seeking an economical cleaner?**

Yes, and I want a non-chlorinated product.

**Environmental  
Contact Cleaner**

**37505**

**Are you looking for the best Plastics Contact Cleaner?**

Yes, and I'm not concerned about the price.

**Plastics  
Contact Cleaner**

**37504**

**Is High Dielectric Strength your main concern?**

Yes, and I want no flash point.

**Plastics  
Contact Cleaner**

**37504**

## CONTACT CLEANER SELECTION GUIDE

Chemical Properties																
Product Description/ Part #	O.K. for These Substrates						Removes These Contaminants						Chemical Properties			
	Fiberglass	Plastic	Rubber	Teflon	Metal	Nylon	Tar/Asphalt	Grease	Ink	Wax	Adhesives	Carbon Dust	Flash Point	Drying Time	Dielectric Strength	Plastic Safe
<b>Flash Free Safety Solvent</b> 37497/37498	—	X	X	X	X	—	A	A	A	B	A	B	None	Fast	37,000	Yes
<b>Electrical Cleaner &amp; Lubricating Spray</b> 37499	—	X	X	X	X	—	A	A	B	B	B	B	None	Fast	36,700	Yes
<b>Environmental Cleaner/Degreaser</b> 37501	—	X	X	X	X	X	B	A	A	B	A	B	-20	Very Fast	N/A	No
<b>Electric Motor Degreaser/Safety Solvent</b> 37502	—	—	X	X	X	—	A	A	A	B	A	A	None	Fast	39,500	No

A = Strong Cleaning Action      B = Good Cleaning Action      C = Moderate Cleaning Action

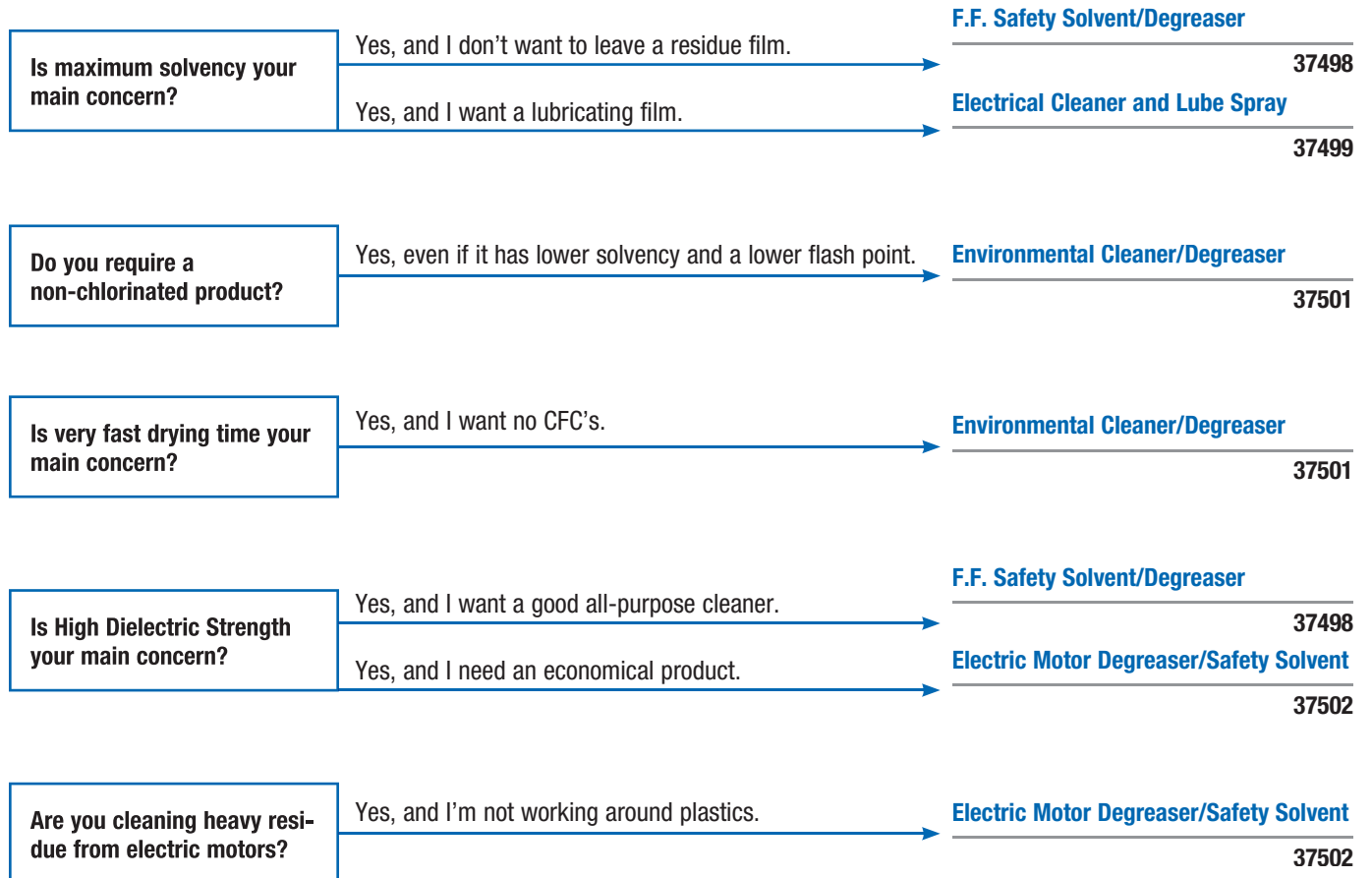

**PAINT & CHEMICALS**

### SPRAYON® CONTACT CLEANERS

Description	MSDS Ref #	Part #	Can Size	Net Fill	Std Pk
Electro Wizard™ Electronic Contact Cleaner	S02206000	<b>37680</b> ★	16 oz	10 oz	12
Plastics Contact Cleaner	S02020	<b>37504</b> ★	16 oz	12 oz	12
Environmental Contact Cleaner	S02302	<b>37505</b> ★	16 oz	11 oz	12
Flash Free Safety Solvent and Degreaser*	S20848	<b>37498</b> ★	20 oz	17 oz	12

\*Features High Delivery Nozzle.

★ Made in USA

#### Sprayon® Electro Wizard™ Electronic Contact Cleaner

##### 37680

A new patent pending formula that instantly removes, dissolves and rinses away foreign contaminants from sensitive equipment and precision instruments. Instant evaporation eliminates trapping of airborne contaminants and allows parts to be handled immediately. Safe on most plastics. D.S. of 12.5 volts. K2 rated, NSF registered.

#### Sprayon® Plastics Contact Cleaner

##### 37504

Versatile cleaning and degreasing agent that quickly removes light contaminants with no residue and no temperature control problems. Can be applied while equipment is operating because of instant evaporation. Safe on most plastics. D.S. of 19.0 volts. K2 rated, NSF registered.

#### Sprayon® Environmental Contact Cleaner

##### 37505

Heavy-duty degreaser and quick-drying cleaner. Ideal for sensitive equipment and precision instruments. Fast-evaporating and leaves no residue. For use on non-energized equipment. Safe on most plastics. K2 rated, NSF registered.

#### Sprayon® Flash Free Safety Solvent

##### 37498

Fast-acting solvent penetrates easily, evaporates quickly and leaves no residue. Excellent cleaning properties make it ideal for removing grease, dirt, wax and metallic particles prevalent in most industrial plants. Non-conductive and non-flammable. Includes extension tube and high delivery nozzle for flush-type applications. D.S. of 37.0 volts. K2 rated, NSF registered.

#### Uses:

Removes oil, grease, dirt and other contaminants from sensitive equipment, electrical contacts and precision instruments.



You can find access to all current MSDS sheets on the Krylon Products Group website.

[www.KPG-Industrial.com](http://www.KPG-Industrial.com)



## SPRAYON® ELECTRICAL & ELECTRONIC CLEANERS & DEGREASERS

Description	MSDS Ref #	Part #	Can Size	Net Fill	Std Pk
Flash Free Safety Solvent & Degreaser*	S00848	<b>37497</b>	16 oz	13 oz	12
Flash Free Safety Solvent & Degreaser†	S20848	<b>37498</b> ★	20 oz	17 oz	12
Electrical Cleaner & Lubricating Spray	S02001	<b>37499</b>	16 oz	16 oz	12
Environmental Cleaner Degreaser	S00749	<b>37501</b> ★	20 oz	15 oz	12
Electric Motor Degreaser/Safety Solvent	S00703	<b>37502</b>	20 oz	19.25 oz	12
Non-Chlorinated Electrical Degreaser	S02084600	<b>37651</b>	20 oz	18 oz	12

\*Features Fine Mist Sprayer.

★ Made in USA

†Features High Flow Valve.

### Sprayon® Flash Free Safety Solvent

#### 37497/37498

Fast-acting solvent penetrates easily, evaporates quickly and leaves no residue. Excellent cleaning properties make it ideal for removing grease, dirt, wax and metallic particles prevalent in most industrial plants. Non-conductive and non-flammable. D.S. of 37,000 volts. K2 rated, NSF registered.

### Sprayon® Electrical Cleaner & Lubricating Spray

#### 37499

Makes high-precision electrical equipment perform like new. Cleans and penetrates surface pores and leaves a fine microscopic corrosion-proof film. Instant cleaning action cuts cost per application. D.S. of 36,700 volts. K2 rated, NSF registered.

### Sprayon® Environmental Cleaner/Degreaser

#### 37501

Designed for fast, effective removal of dirt, oil, grease, wax and tar on electrical equipment. For use on non-energized equipment. Leaves no residue—fast evaporating. K2 rated, NSF registered.

### Sprayon® Electric Motor Degreaser

#### 37502

A chlorinated solvent that penetrates quickly to easily lift dirt, grease and tars. Ideal for electrical equipment. Requires no washing or flushing—simply spray on and wipe off. Will not harm insulators or leave a residue. K2 rated, NSF registered.

#### Uses:

Removes grease, dirt, dust and oxidation residue from electric motors, gears, cables, generators, molds, chains and fuse holders. Some products also apply a corrosion proof film.



You can find access to all current MSDS sheets on the Krylon Products Group website.

[www.KPG-Industrial.com](http://www.KPG-Industrial.com)

### Sprayon® Non-Chlorinated Electrical Degreaser

#### 37651

A non-chlorinated, non-flammable, fast-evaporating cleaner penetrates instantly to remove dirt, oil, grease and wax. Increases the life of electrical components by removing foreign materials that can cause costly downtime. Degreases more thoroughly and several times faster than alkaline cleaners. Excellent for degreasing aluminum, cleaning sheet and strip steel prior to galvanizing. D.S. of 15.0 volts. K2 rated, NSF registered.

### SPRAYON® LUBRICANTS • SPECIALTY AND GENERAL PURPOSE

Description	MSDS Ref #	Part #	Can Size	Net Fill	Std Pk
711® Protector™ Lubricant (Aerosol)	S00711	<b>37508</b> ★	16 oz	11 oz	12
Rust Breaker™ Penetrant	S00103	<b>37509</b> ★	16 oz	12 oz	12
Premium Silicone Lube (6.6%)	S01324	<b>37510</b> ★	16 oz	10 oz	12
H. D. Open Gear/Wire Rope Lube	S00201	<b>37511</b> ★	16 oz	12 oz	12
Cutting Oil	S00208	<b>37513</b> ★	16 oz	12 oz	12

★ Made in USA

#### Uses:

Reduces friction and stops squeaks and sticking by displacing moisture and repelling water from lugs, bolts, gears, cables, roller chains, machine tools, connectors, linkages and production equipment of all kinds.



#### Sprayon® Heavy Duty Open Gear/Wire Rope Lube

**37511**

Penetrates to core of wire rope, minimizing internal friction. “Travels” on metal surfaces, displacing water to provide excellent rust protection. Withstands extreme pressure with maximum adhesive and works from 0° to 250°F. Penetrates pores of surfaces without heating. H2 rated, NSF registered.

#### Sprayon® 711® Protector™ Lubricant

**37508**

Excellent choice to penetrate, lubricate, demoisurize and inhibit corrosion. Ultra-thin, greaseless formulation. Does not attract contaminants. Safe on plastic surfaces. H2 rated, NSF registered. High D.S. 47,000 volts.

#### Sprayon® Rust Breaker™ Penetrant

**37509**

Transparent, non-staining oil loosens rust and releases frozen lugs, bolts and tight fitting parts. H2 rated, NSF registered. Won't harm painted surfaces. D.S. of 33,000 volts.

#### Sprayon® Premium Silicone Lube

**37510**

6.6% silicone formula stops squeaks and sticking, eliminates friction, repels water and prevents freezing. Does not harden or degrade from -40° to 400°F. Apply to wood, metal, fabric, rubber or leather. Keeps rubber soft and flexible.

#### Sprayon® Cutting Oil

**37513**

Extends tool life, reducing tool sharpening and downtime. Recommended for all metals, including stainless steel and soft metals such as aluminum, brass and copper. Clings to surface. Jet-spray allows precision applications. H2 rated, NSF registered.

You can find access to all current MSDS sheets on the Krylon Products Group website.

[www.KPG-Industrial.com](http://www.KPG-Industrial.com)

## SPRAYON® & KRYLON® INDUSTRIAL • CORROSION INHIBITORS & INSULATING VARNISHES

- Protects metal surfaces from the damaging effects of corrosive environments.

Description	MSDS Ref #	Part #	Can Size	Net Fill	Std Pk
Zinc Rich Cold Galvanizing Compound (Aerosol)	S00740	<b>37518</b> ★	16 oz	14 oz	12
Clear Insulating Varnish	S00600	<b>37520</b> ★	16 oz	14 oz	12
Red Insulating Varnish	S00601	<b>37521</b> ★	20 oz	15.25 oz	12
Long Term Indoor Protectant and Lube	S00767	<b>37528</b> ★	16 oz	11 oz	12
Red Oxide Rust Control Primer	S00339	<b>37529</b> ★	16 oz	12 oz	12

★ Made in USA

### Sprayon® Zinc Rich Cold Galvanizing Compound

#### 37518

Fast-drying, high-solids, high-performance epoxy based coating. Provides maximum protection to steel exposed to severe corrosive environments. Fuses zinc to the metal substrates to protect against corrosion. Equal to or better than hot-dipped galvanizing. 97% pure zinc dust.

### Sprayon® Insulating Varnish

#### 37520/37521

Thoroughly penetrates old and new materials. Air-dries faster than most insulating aerosols. Provides high adhesion, high arc resistance and non-tracking properties. Resists abrasion and wear. D.S. up to 2,200 volts.

### Sprayon® Long Term Indoor Protectant and Lube

#### 37528

Penetrates thoroughly and forms a tough, flexible film. High arc resistance and non-tracking properties. Resists oil, water, acids and alkalis. Excellent adhesion.

### Krylon® Industrial Tough Coat® Red Oxide Rust Control Primer

#### 37529

Specially formulated for a variety of industrial applications. Ideal for light to heavy duty painting projects, both indoors and outdoors. Smooth, even coverage. Fast drying—dries to the touch in just 15 minutes.



You can find access to all current MSDS sheets on the Krylon Products Group website.

[www.KPG-Industrial.com](http://www.KPG-Industrial.com)

## SPRAYON® GENERAL PURPOSE & GLASS CLEANERS



### Uses:

Removes grimy dirt, grease and oil from a wide variety of industrial surfaces.

Description	MSDS Ref #	Part #	Can Size	Net Fill	Std Pk
General Purpose Cleaner	S00880	<b>37524</b> ★	20 oz	19 oz	12
Heavy Duty Glass Cleaner	S00888	<b>37525</b> ★	20 oz	18 oz	12
Neutra-Force® Heavy Duty Foaming Degreaser	S1201S1219	<b>37495</b> ★	20 oz	19 oz	12

★ Made in USA

### Sprayon® General Purpose Cleaner

#### 37524

All-purpose formula that cuts through dirt with ease. Effective and safe to use on metal, finished wood, porcelain, vinyl, leather, laminated surfaces and glass. Cleans spots on synthetic carpets. C1 rated, NSF registered.

### Sprayon® Heavy Duty Glass Cleaner

#### 37525

Removes soil, smoke haze, finger prints, road film and surface smears. Cleans any surface not normally harmed by water. Will not cloud plastic materials. Resists streaking—wipes clean. C1 rated, NSF registered.

### Sprayon® Neutra-Force® Heavy Duty Foaming Degreaser

#### 37495

A degreaser that delivers fast and effective cleaning on a variety of industrial soils. It contains no caustics, alkali, phosphates, or silicates. Powerful foaming action clings to surface and effectively breaks-down contaminants for effortless removal. Contains no fragrance or dyes and is acceptable as an A1 rated cleaner in food processing facilities.

You can find access to all current MSDS sheets on the Krylon Products Group website.

[www.KPG-Industrial.com](http://www.KPG-Industrial.com)

## KRYLON® EASY-TACK™ REPOSITIONABLE ADHESIVE

- Repositionable adhesive temporarily and precisely holds lightweight materials.
- Temporary positioning can be adjusted, removed and reapplied throughout the life of the bond.
- Long-lasting tack, non-wrinkling, and low-odor.
- Dry to touch in 3 hours.
- For use with plastic, glass, plaster, ceramic, and fabric.



Description	MSDS Ref #	Part #	Can Size	Net Fill	Std Pk
Repositionable Adhesive	7020	<b>37595</b> ★	10.25 oz	5.50 oz	6

★ Made in USA

## SPRAYON® INSECTICIDES & INSECT REPELLENTS • INDUSTRIAL GRADE

Description	MSDS Ref #	Part #	Can Size	Net Fill	Std Pk
Blast 'Em Wasp & Hornet Spray	S00857	<b>37522</b> ★	16 oz	12 oz	12
Blast 'Em Wasp & Hornet Spray	S02085700	<b>37525</b> ★	20 oz	14 oz	12
Insect Repellent II	S00856	<b>37523</b> ★	8 oz	6 oz	12

★ Made in USA

### Sprayon® Blast'Em Wasp & Hornet Spray

#### 37522 & 37525

Contains a high amount of petroleum distillates for the best knockdown and kill rate. Residual deposit will kill returning wasps and hornets. Will not harm most plastics. 98% knockdown, 100% kill within 24 hours. D.S. of 33,000 volts. Sprays up to 20 feet. EPA registered.

### Sprayon® Insect Repellent II

#### 37523

Effectively repels mosquitoes, chiggers, ticks, deer flies, stable flies, black flies, gnats and fleas. Protects against Lyme disease. Can be applied to skin, clothing and anywhere that insects are a problem. Does not contain R-11. EPA registered.



**Uses:**  
Jobsite protection.

**PAINT & CHEMICALS**

You can find access to all current MSDS sheets on the Krylon Products Group website.

[www.KPG-Industrial.com](http://www.KPG-Industrial.com)

### LUMBER CRAYONS

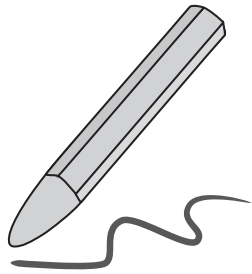

- Use to mark on a variety of surfaces – including metal, wood and plastic.
- Resists smearing and fading from exposure to water and sun.



**67410**

Color	Part #	Unit	Std Pk
Red	<b>67400</b> ★	12	144
Yellow	<b>67402</b> ★	12	144
Blue	<b>67404</b> ★	12	144
Black	<b>67405</b> ★	12	144
Lumber Crayon Holder	<b>67410</b> ★	12	12

★ Made in USA

### DURA-INK® 15 BLACK MARKER.



This fine bullet tip marker produces accurate and easily readable, thin marks, making it ideal for everything from the shop floor to the shipping room, and parts identification to layout work.

- Black ink contain low halogens.
- Extra tough tip won't spread or mush.
- Smear-resistant, water-resistant, fast-drying.

#### Applications

- Marks on metal, wood, cardboard, paper, plastic, glass, etc.
- For identification of parts, layout work, and marking cartons and crates.
- Fine point for fine line marking.

Description	Part #	Std Pk
Dura-Ink® 15 Black Marker with Fine Bullet Tip	<b>10030</b>	1*

\*48 Piece Canister

### I, I, I Trichloroethane 224

Also called I, I, I trichlor. A chlorinated solvent now banned by the EPA. Sometimes confused with Trichloro-ETHYLENE, a permitted solvent.

### Chlorinated Solvents (CFCs & HCFCs)

Common ozone-depleting solvents gradually being phased out by the EPA.

### Date Code

Date of production, indicated by a 4-digit code on the bottom of the can. The first 3 digits indicated the numerical day of the year, the 4th digit indicates the year, For example 1818=181st day of 1998 (June 30, 1998). Most paints and chemicals have a shelf life of 3 years from date of manufacture.

### Dielectric Strength

A measurement of how well a spray conducts electricity (in Kilovolts per millimeter). A high dielectric strength indicates that a spray is not a good conductor of electricity (which makes it a relatively safe choice for use around electrified equipment). Most low conductivity cleaners will have dielectric strengths ranging from 15,000 to 47,000 (safest).

### Flammability

Flammability is rated on a 0 to 4 scale, with 0 being the safest and 4 being the most flammable. This information is printed on each MSDS sheet. When selecting a cleaner for degreaser, the first thing you may want to determine is whether the application requires a non-flammable product.

### Flash Point

Lowest temperature at which vapors from an aerosol formula will ignite in air when exposed to a flame. When you see a product with a flash point of -20°F this means the most flammable component in the aerosol can ignite at -20°F. The actual aerosol spray, a mixture of a number of chemicals, will generally remain stable to a much higher temperature.

### MSDS

These sheets list the individual ingredients contained in each product and identify the potential health, fire, explosion and reactivity risks. They also provide a list of precautions and remedies for most common problem situations. A number of government agencies require that these be supplied upon request. You can find access to all current MSDS sheets on the Krylon Products Group website, [www.KPG-Industrial.com](http://www.KPG-Industrial.com)

### Net Weight

The amount of material that is evacuated or sprayed from the can. It is common in the chemical industry to promote full can weight (which includes propellant). When comparing Krylon Products Group products with those of other manufacturers, be sure to compare actual net weights.

### Ozone Depleters

None of our products are class I ozone depleters (the most restricted). Only two are classified II depleters: Safety Cleaner and Degreaser II and Contact Tuner and Cleaner.

### Plastic Safe

Some cleaners and degreasers work so well that they dissolve some plastic insulating materials. Plastic safe cleaners, on the other hand, are gentle enough to be applied directly to plastic surfaces.

### Residue

This term has two meanings. Some aerosol sprays are designed to leave a fine lubricating film on the machine surface. In common vernacular, *residue* also refers to the sticky film left by a poor-performing product.

### Solvency (KB Value)

A measure of how well an electronic cleaner dissolves impurities. The higher the number, the stronger the cleaner; the lower the number, the weaker the cleaning effect. It's important to keep in mind that "weaker" is not necessarily a bad thing. It just means the product is designed to be a more gentle cleaning agent.

### Technical Support

If you have a specific application question or are looking for a Krylon Products Group cross-reference to a competitor's product, please call Krylon Products Group technical support 800-251-2486.

### NSF Registration

Following the 1998 termination of the USDA authorization and listings program for propriety substances and non-food compounds, NSF International was requested to continue the program with advice from USDA. Certain lubricants and cleaners are registered by NSF for use in food manufacturing.

### VOC (Volatile Organic Compounds)

These materials are a major contributor to urban smog and some regions have created laws to limit their use, especially in California and the OTC states in the northeastern U.S.

### WHITE LIGHTNING® SILICONE SEALANT



- Provides a watertight seal.
- Use for interior and exterior projects.
- Highly, permanently flexible.
- Will not crack, crumble or shrink.
- Resists moisture and mildew.
- Excellent adhesion to non-porous materials.
- Not paintable.
- NSF compliant.
- Complies with TT-S-00230C, TTS-001543A, ASTM C-920.

Description	MSDS Ref #	Part #	Can Size	Std Pk
100% RTV Silicone Sealant – Clear	WL9010	<b>37530</b> ★	10 oz	12
100% RTV Silicone Sealant – White	WL9210	<b>37531</b> ★	10 oz	12
EZ-Thrust Caulk Gun	—	<b>96000</b> ★	—	1

★ Made in USA

### SPRAYON® CLEAR SILICONE



- Chemically stable.
- Shows little change in physical properties after exposure to sunlight, rain, snow, ozone, temperature extremes and weathering.
- Mildew resistant.
- Long tooling time of 5–10 minutes.
- P1 rated, NSF registered.

Description	Part #	Net Fill	Std Pk
RTV Clear Silicone Sealant	<b>96070</b> ★	7.25 oz	12

★ Made in USA

### TRI-FLOW® LUBRICANTS WITH P.T.F.E.



- Lubricates with oils, additives and P.T.F.E. to reduce friction and increase part life.
- Penetrates inaccessible areas to displace contaminants.
- Rejects dirt, dust, and other abrasive particles.
- Effective from -60° to 475°F.
- H2 rated, NSF registered.
- Offers 10 times as much load capacity as WD-40 in a standard Falex-Load Text (ASTM D-3233b).

Uses:		
• Machinery	• Conveyors	• Bearings
• Cables	• Gears	

Description	Container	MSDS Ref #	Part #	Can Size	Net Fill
Industrial Lubricant	Aerosol Can	TF20025	<b>37514</b> ★	12 oz	6 oz
Industrial Lubricant	Trigger Spray Bottle	TF29200	<b>37515</b> ★	6 oz	18 oz
Industrial Lubricant	Non-Aerosol	TF21010	<b>37516</b> ★	12 oz	2 oz

★ Made in USA

PAINT & CHEMICALS



### WHITE LIGHTNING® STOP GAP!™ • EXPANDING FOAM

- Dries tack free in less than 30 minutes.
- Cures in 8 hours.
- Cured product can be trimmed, shaped, sanded, painted or stained.
- Can be applied at temperatures between 60°F and 100°F.
- Great for use on corner and T-joints, exterior sheeting, openings and gaps at the plate line, masonry and concrete or wood walls.



Description	MSDS Ref #	Part #	Can Size	Net Fill	Std Pk
Triple Expanding Insulating Foam	WL3333300	<b>96060</b> ★	16 oz	12 oz	8

★ Made in USA

### WET PATCH ROOF CEMENT

- Asbestos free.
- Meets ASTM D4586, ASTM D2822 and Fed Spec SS-C-153C, Type 1.
- Black fibered asphalt mastic works to seal and stop leaks.
- Easy to spread with a small mason's trowel, putty knife or caulking gun.
- Apply at a thickness of 1/4" to form a tight weatherproof seal – even sticks in the rain!



Size	MSDS Ref #	Part #	Unit	Std Pk
10.3 oz Tube	RC016	<b>96010</b> ★	1	24
1 Gallon	RC016	<b>96030</b> ★	1	4

★ Made in USA

### E-6000® INDUSTRIAL ADHESIVE • ABRASION RESISTANT SEALANT

- Maintains its adhesion sealant properties even when submerged under water.
- Paintable with water or oil based paints.
- Exceptionally flexible-can stretch to 600% of its length.
- Cures in 8 hours as sealant; 24 hours as an adhesive at 70°.
- 5 year shelf life (unopened).

#### Uses:

- Sealing circuit boards.
- Sealing junction boxes.
- Insulating electrical connections.
- Re-coating insulating wiring and cables.
- Exceptional adhesion to metal, wood, concrete, glass, masonry, fiber glass and ceramics.
- Adheres to many plastics, leather, rubber and vinyl.



Description	Color	Part #	Tube Size	Box Qty
E-6000® Squeeze Tube	Clear	<b>96040</b> ★	3.7 oz	12
E-6000® Caulk Tube	Clear	<b>96050</b> ★	10.2 oz	12
UV-6800 Square Tube	Clear	<b>96140*</b> ★	3.7 oz	12
UV-6800 Caulk Tube	Clear	<b>96150*</b> ★	10.2 oz	12

\*UV-6800 works the same as E-6000® but offers special resistance when full sunlight exposure is a concern.

★ Made in USA

### DARK CUTTING OIL • FOR CUTTING FERROUS MATERIALS



- Developed for smooth, easy cutting of ferrous materials and ferrous alloys.
- Pleasant to work with. Easy to see with a mild odor.
- May stain non-ferrous materials.

Application	MSDA Ref #	Part #	Size	Case Qty
For Cutting Ferrous Materials	TCO 14	<b>96035</b> ★	Gallon	4

★ Made in USA

### DUCT SEAL COMPOUND • EASILY MOLDED • SEALS INSTANTLY



- Seals around conduit openings and junction boxes.
- Adheres to most clean surfaces (for indoor applications).
- Paintable and will not harden.
- Non-conducting, non-toxic, non-corrosive and non-staining.
- UL Listed.
- 1 year shelf life.
- Contact customer service for pallet quantities.

Size	Part #	Unit	Case Qty
1# Plug	<b>14300</b> ★	1	50
5# Plug	<b>14305</b> ★	1	10

★ Made in USA

### ALL PURPOSE RAGS • INDUSTRIAL WIPING CLOTHS

Description	Part #	Qty
New Bleached Knits	<b>37580</b> ★	1 lb Bag of Rags
New Bleached Knits	<b>37582</b> ★	5 lb Box of Rags
New Bleached Knits	<b>37584</b> ★	25 lb Box of Rags
New Bleached Knits	<b>37586</b> ★	50 lb Box of Rags
Recycled White T-Shirts	<b>37587</b> ★	25 lb Box of Rags
Recycled White T-Shirts	<b>37588</b> ★	50 lb Box of Rags
Recycled Colored T-Shirts	<b>37590</b> ★	25 lb Box of Rags
Recycled Colored T-Shirts	<b>37591</b> ★	50 lb Box of Rags



★ Made in USA

### SCRUBS-IN-A-BUCKET®

- Citrus-based formula works fast to loosen, dissolve and absorb dirt, grease and grime.
- Perforated high-strength absorbent cleaning towels leave no residue.
- Can be used anywhere on the toughest soils, greases, tar and even ink.
- Safe for use on painted surfaces, composites, tools, equipment, plastics, vinyl and hands.



#### Safely Removes:

- |            |            |              |            |             |
|------------|------------|--------------|------------|-------------|
| • Dirt     | • Adhesive | • Tar        | • Epoxy    | • Paint     |
| • Sealants | • Oils     | • Lubricants | • Urethane | • Ink & Dye |
| • Grease   | • Caulk    |              |            |             |

Description	Part #	Wipes/Bucket	Std Pk
Scrubs-in-a-Bucket®	<b>37440</b> ★	72	6

★ Made in USA



### FIRESTOP PUTTY PAD



- One pad thickness (1/8") provides a 1 to 2 hour fire rating.
- Meets ASTM E814, UL1479 and ULC/CAN4-S115-M.
- Covers two gang boxes.

Description	Size-	MSDS REF #	Part #	Case Qty
Firestop Putty Pad	6" x 7" x 1/8" Thick	0216	<b>96230</b> ★	20

★ Made in USA

### LECTRA-STOP™



- One step, one component system.
- Expands to seal openings when exposed to fire.
- Sound rated 55 STC.ASTM E84, UL 723 Tunnel Test. Two hour rating.
- Applies to back of box.
- Intumescent.

Description	MSDS REF #	Part #	Case Qty
Lectra-Stop™ Single Gang	0480	<b>96234</b> ★	50
Lectra-Stop™ Double Gang	0480	<b>96236</b> ★	50

★ Made in USA

### FIRESTOP GASKETS

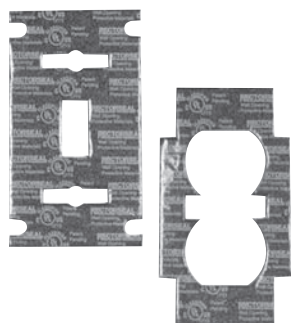

- One step, one component system.
- Expands to seal opening when exposed to fire.
- UL 723 tunnel test. 1 to 2 hour rating.
- Applies between receptacle and cover.
- Intumescent.

Visit [www.biofireshield.com](http://www.biofireshield.com) for detailed information on fire stopping products.

Description	MSDS REF #	Part #	Case Qty
Firestop Gasket Single Receptacle	0591	<b>96238</b> ★	50
Firestop Gasket Double Receptacle	0591	<b>96240</b> ★	50
Firestop Gasket Single Switch	0591	<b>96242</b> ★	50
Firestop Gasket Double Switch	0591	<b>96244</b> ★	50

★ Made in USA

#### Intumescent

Firestop products referred to as "intumescent" expand at high temperatures to fill gaps and contain fire and smoke.

## FIRESTOP PUTTY STICKS

- Seals around electrical cables, conduit and metal pipes.
- ASTM E814, UL1479 and ULC/CAN4-S115M.
- Two hour rating.



Description	MSDS REF #	Part #	Case Qty
Firestop Putty Sticks	0216	<b>96232</b> ★	12

★ Made in USA

## FIRESTOP CAULK

- Intumescent

Description	Rating Size	Case Hours	MSDS REF #	Part #	Case Qty
Firestop Caulk 150+	10.3 oz	1-2	0582	<b>96062</b> ★	24
Firestop Caulk 150+ (Sausage Pack)	20.2 oz		0582	<b>96064</b> ★	12
Firestop Caulk 150+	5 Gal		0582	<b>96066</b> ★	1
Firestop Caulk 500+	10.3 oz	4	0200	<b>96055</b> ★	24
Firestop Caulk 500+ (Sausage Pack)	20.2 oz		0200	<b>96058</b> ★	12
Firestop Caulk 500+	5 Gal		0200	<b>96059</b> ★	1
Caulking Gun for Sausage Pack			—	<b>96002</b>	1

★ Made in USA



## FIRESTOP PILLOWS

- Designed for large openings with cables, cable trays, blank openings or multiple penetrating items.
- Three hour rating.
- Most economical firestop pillows available.
- Intumescent.

Size	Part #	Case Qty
2" x 9" x 6"	<b>96246</b> ★	10
3" x 9" x 6"	<b>96248</b> ★	10

★ Made in USA



Size	Blade	Handle	Grip	Weight (lbs)	Part #
Size 2 Round Point Shovel	Hollow Back 8 <sup>7</sup> / <sub>8</sub> " x 11 <sup>3</sup> / <sub>4</sub> "	47" Fiberglass	Double-Dip	5.00	<b>37250</b>
Size 2 Round Point Shovel	Hollow Back 8 <sup>7</sup> / <sub>8</sub> " x 11 <sup>3</sup> / <sub>4</sub> "	27" Fiberglass	D-Grip	4.50	<b>37251</b>
Size 2 Square Point Shovel	Hollow Back 8 <sup>5</sup> / <sub>8</sub> " x 11 <sup>1</sup> / <sub>4</sub> "	47" Fiberglass	Double-Dip	4.75	<b>37253</b>
Size 2 Mud Round Point Shovel	Hollow Back 8 <sup>1</sup> / <sub>4</sub> " x 11 <sup>1</sup> / <sub>2</sub> "	47" Fiberglass	Double-Dip	4.95	<b>37160</b>
Size 2 Mud Square Point Shovel	Hollow Back 8 <sup>3</sup> / <sub>4</sub> " x 11 <sup>1</sup> / <sub>4</sub> "	47" Fiberglass	Double-Dip	4.95	<b>37161</b>
4" Classic Trench Shovel	Hollow Back 4" x 12"	48" Fiberglass	Double-Dip	3.50	<b>37262</b>
4" Step Trench Shovel	Steel, Forward Step 4" x 11"	47" Fiberglass	Double-Dip	4.00	<b>37163</b>
3" Step Trench Shovel	Steel, Forward Step 3" x 11"	47" Fiberglass	Double-Dip	4.00	<b>37164</b>
5" Step Trench Shovel	Steel, Forward Step 5" x 11"	47" Fiberglass	Double-Dip	4.75	<b>37165</b>
4" Trench Clean-Out Shovel	Steel 4" x 10"	60" Fiberglass	Vinyl	3.75	<b>37267</b>
Forged Head 16 Tine Bow Rake	16 <sup>3</sup> / <sub>4</sub> " x 3" Curved Steel Tines	60" Fiberglass	Double-Dip	4.00	<b>37166</b>
Forged Level Head Rock Rake	16 <sup>3</sup> / <sub>4</sub> " x 3" Straight Steel Tines	66" Fiberglass	Double-Dip	4.25	<b>37167</b>
Small-Head Irrigating/Floral	Hollow Back 6" x 8 <sup>1</sup> / <sub>2</sub> "	46" Fiberglass	Vinyl	2.75	<b>37256</b>
Small-Head Irrigating/Floral	Hollow Back 6" x 8 <sup>1</sup> / <sub>2</sub> "	22" Fiberglass	D-Grip	2.00	<b>37257</b>
Small-Head Irrigating/Floral	Hollow Back 6" x 8 <sup>1</sup> / <sub>2</sub> "	31" Fiberglass	Vinyl	2.50	<b>37263</b>
14" Drain Spade/Sharp Shooter	Hollow Back 5 <sup>3</sup> / <sub>4</sub> " x 14"	48" Fiberglass	Double-Dip	5.00	<b>37259</b>
14" Drain Spade/Sharp Shooter	Hollow Back 5 <sup>3</sup> / <sub>4</sub> " x 14"	30" Fiberglass	D-Grip	4.25	<b>37162</b>
Sledge Hammer	8 lb. Double-Faced Head	36" Fiberglass	None	10.00	<b>37275</b>
Sledge Hammer	10 lb. Double-Faced Head	36" Fiberglass	None	12.00	<b>37277</b>
Sledge Hammer	12 lb. Double-Faced Head	36" Fiberglass	None	14.00	<b>37279</b>
Pick Mattock	5 lbs. Head w/#6 Eye	36" Fiberglass	None	7.50	<b>37273</b>
48" Utility Probe	3/4" Steel Tip on 1/2" Fiberglass Rod	8 1/4" Fiberglass	Vinyl	1.50	<b>37265</b>
Post Hole Digger	Head 9 1/2" x 6 1/2" w/6 1/4" Spread	48" Fiberglass	Double-Dip	10.00	<b>37269</b>
All Purpose Bar w/Tamper	Forged Wedge 2" x 9"	1" x 48" Steel Pipe	2 1/2" Taper	7.50	<b>37271</b>



### Our Handle on Quality

Hollow fiberglass handles may be fine for recreational use but if you must rely on your hand tools everyday, Cully's fiberglass handles have a legacy of premium performance. All Cully handles are produced from thousands of continuous strands of fiberglass saturated with thermosetting resins and non-fiberglass polyester veil impregnated on the surface. The veil gives the handle a smooth finish and keeps the fiberglass from splintering.

### Benefits of Fiberglass

- Greater strength pound for point than steel.
- Will not transmit heat or cold, and will not conduct electricity.
- Will not absorb moisture or warp.
- Is non-corrosive and resistant to acids and other chemicals.
- Is highly resistant to temperature changes.
- Resists impact, is non-denting and difficult to damage.
- Minimizes handle breakage and saves on-the-job downtime.

1. Our signature fiberglass handle used on our digging tools

feature a thick wall fiberglass tube, which is less flexible than poly-molded handles, and has a solid fiberglass inner core in the base followed by a hardwood core through the remaining portion of the handle. The solid fiberglass core extends the stress point above the critical neck or collar portion of the handle which increases its overall strength and durability.



2. All of our long handle digging tools feature our new 8-inch Tuffoam double-dip grips which have been designed for the toughest industrial applications. The grips feature a durable, vinyl inner liner and a comfortable, non-slip foam exterior that provides long life and helps prevent potential harmful hand fatigue.
3. On tools that require less strength, such as rakes, we use a fiberglass handle with a honeycomb plastic core.
4. Our D-Grips, used on short and midlength handled tools, are made of one-piece high-density nylon.

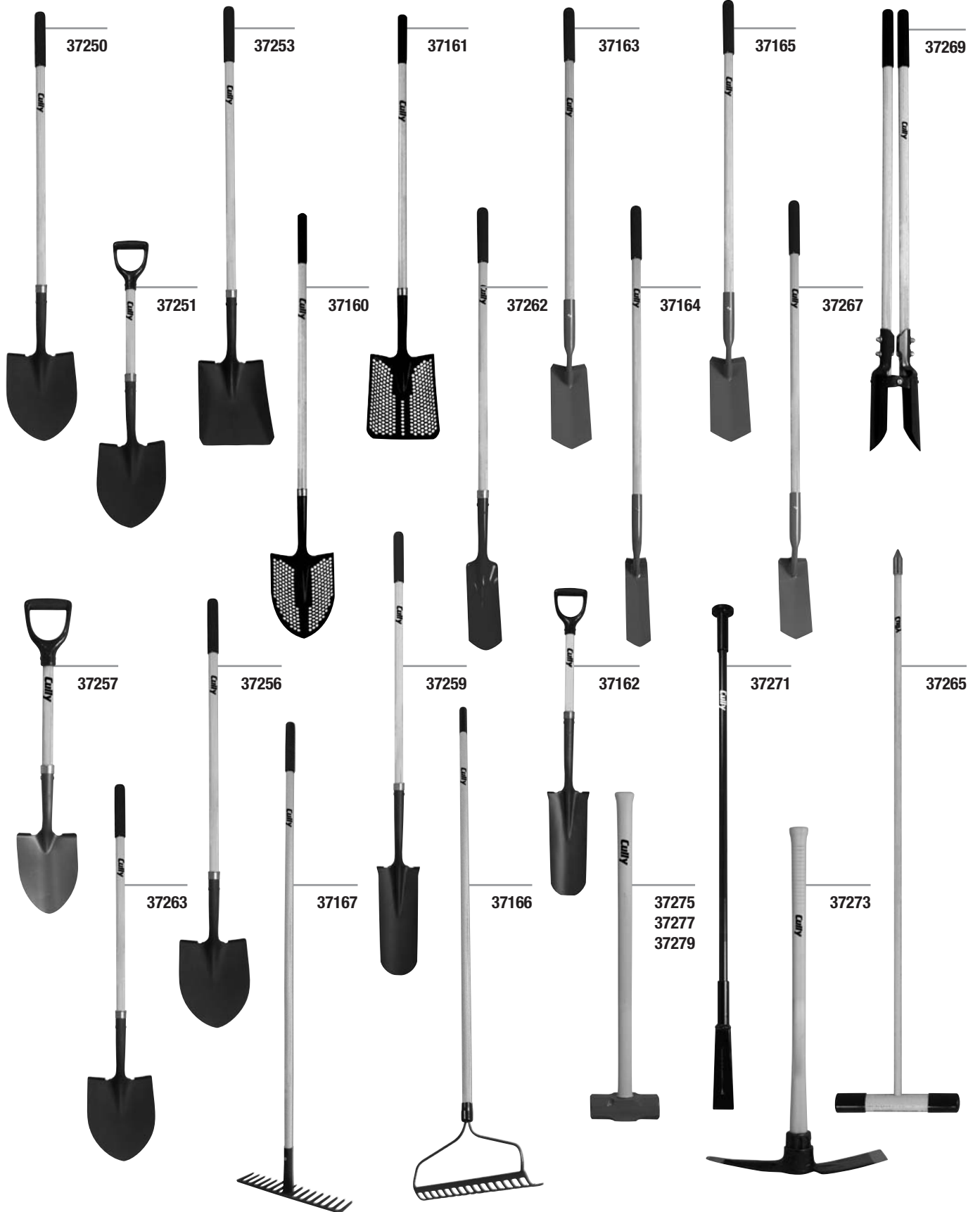

TOOLS

See page 283 for our shovel display offer!

### ELECTRICIAN COMFORT COMBOS



Metal Buckle



Quick Release Buckle



Description	Buckle	Size	Color	MFG #	Part #
Ultimate Electrician Comfort Combo	Metal	Sm 28" – 32"	R. Blue	ULT104RYS	<b>39340</b> ★
Ultimate Electrician Comfort Combo	Metal	Med 32" – 36"	R. Blue	ULT104RYM	<b>39342</b> ★
Ultimate Electrician Comfort Combo	Metal	Lg 36" – 40"	R. Blue	ULT104RYL	<b>39344</b> ★
Ultimate Electrician Comfort Combo	Metal	XL 40" – 44"	R. Blue	ULT104RYXL	<b>39346</b> ★
Ultimate Electrician Comfort Combo	Metal	Lg 36" – 40"	Black	ULT104BKL	<b>39343</b> ★
Electrician Comfort Combo	Metal	Med 32" – 36"	Black	104BKM	<b>39370</b> ★
Electrician Comfort Combo	Metal	Lg 36" – 40"	Black	104BKL	<b>39373</b> ★
Electrician Comfort Combo	Quick Release	Sm 28" – 32"	R. Blue	100RYS	<b>39348</b> ★
Electrician Comfort Combo	Quick Release	Med 32" – 36"	R. Blue	100RYM	<b>39350</b> ★
Electrician Comfort Combo	Quick Release	Lg 36" – 40"	R. Blue	100RYL	<b>39352</b> ★
Electrician Comfort Combo	Quick Release	XL 40" – 44"	R. Blue	100RYXL	<b>39354</b> ★

★ Made in USA

### POUCHES & BAGS



- The entire Boulder Bag line is available. Call for details.

Description	Color	MFG #	Part #
Ultimate Connect-a-Pouch	Blue	Ult110RY	<b>39336</b> ★
Ultimate Electrician Tool Pouch	Blue	Ult120RY	<b>39338</b> ★
7 Pocket Pouch	Blue	110RY	<b>39358</b> ★
Electrician Tool Pouch	Blue	120RY	<b>39360</b> ★
Carry-All Bag		830	<b>39368</b> ★

★ Made in USA

### BELTS & SUSPENDERS



Description	Buckle	Size	Color	MFG #	Part #
Comfort Belt	Quick Release	Med 32" – 36"	Black	500M	<b>39318</b> ★
Comfort Belt	Quick Release	Lg 36" – 40"	Black	500L	<b>39320</b> ★
Comfort Belt	Quick Release	XL 40" – 44"	Black	500XL	<b>39319</b> ★
Comfort Belt	Metal	Med 32" – 36"	Black	504M	<b>39322</b> ★
Comfort Belt	Metal	Lg 36" – 40"	Black	504L	<b>39324</b> ★
Comfort Belt	Metal	XL 40" – 44"	Black	504XL	<b>39325</b> ★
Padded Suspenders			Black	527BK	<b>39335</b> ★

★ Made in USA

### ACCESSORIES



Description	Size	Color	MFG #	Part #
Meter Pouch	7½"H x 3"W x 1¼"D	Black	140BK	<b>39312</b> ★
Small Meter Pouch	6"H x 2¾"W x 1½"D	Black	141BK	<b>39314</b> ★
Drill Pouch	10"H x 6"W x 1½"D	Black	440BK	<b>39316</b> ★
Hammer Holder	—	Black	530BK	<b>39328</b> ★
Blade Guard	—	Black	595BK	<b>39330</b> ★
Phone Case	5½"H x 2¾"W x 1¼"D	Black	607BK	<b>39332</b> ★
Phone Case	5"H x 1¾"W x 1½"D	Black	614BK	<b>39334</b> ★
Tape Clip	—	Black	545	<b>39356</b> ★
Phone Case	5½"H x 2"W x 1½"D	Black	601	<b>39362</b> ★
Phone Case	4"H x 2"W x 1"D	Black	617	<b>39364</b> ★

★ Made in USA



### Electrician Comfort Combo

**39348–39354**

- Tape Clip (39356)
- 7 Pocket Pouch (39358)
- Hammer Holder (39328)
- Electrician Tool Pouch (39360)
- Comfort Belt with Quick Release Buckle (39318/39320)
- 11 Slots, 14 Pockets
- Quick Release Belt



### Ultimate Electrician Comfort Combo

**39340–39346**

- Ultimate Connect-A-Pouch (39336)
- Hammer Holder (39328)
- Ultimate Electrician Tool Pouch (39338)
- Comfort Belt with Metal Buckle (39322/39324)
- 13 Slots, 19 Pockets
- Metal Buckle



### Ultimate Connect-A-Pouch

**39336**

- Divided Main Compartment
- Large Divided Exterior Pocket
- Interior Pocket
- 2 Connect-A-Pouch Loops
- Upper Velcro Pocket with 4 Elastic Slots



### Ultimate Electrician Tool Pouch

**39338**

- Main Compartment
- 3 Exterior Pockets
- 4 Exterior Slots
- Exterior Tape Pocket
- Interior Utility Knife Pocket
- 6 Interior Pockets
- 3 Interior Slots



### 7 Pocket Pouch

**39358**

- Main Compartment
- 2 Interior Pockets
- 2 Large Exterior Pockets
- 2 Exterior Side Pockets



### Electrician Tool Pouch

**39360**

- Divided Main Compartment
- Interior Utility Knife Pocket
- 2 Exterior Pockets
- 6 Exterior Slots
- Interior Pencil Pocket
- Interior Large Pocket
- 5 Interior Slots
- Tape Chain
- Tool Clip



### Carry-All-Bag

**39368**

- 20 Outside Pockets
- 14 Inside Pockets
- Semi-Rigid Construction



### MEGAPRO+ 15-IN-1 SCREWDRIVER

#### Fully Loaded Driver

Description	Part #	Qty
Cully Blue	37200*	1

\*Replaces part numbers: 37291, 37292, 37293, 37294, 37295.

#### Bit Load

Phillips		Square		Star		Slot
#0	#1	#0	#1	T10	T20	#4
#3	#2	#3	#2	T15	T25	#6

#### Replacement Bits

Description	Part #	Qty
T10-T15 Star Bit*	40021	1
T20-T25 Star Bit*	40022	1
#0 & #3 Phillips*	40003	1
#1 & #2 Phillips*	40004	1
#0 & #3 Square Drive*	40005	1
#1 & #2 Square Drive*	40006	1
#4 & #6 Slotted Drive*	40007	1
¼ Mag Nut Setter	40008	1
⅝ Mag Nut Setter	40009	1

\*Driver comes packed with bits.

TOOLS



### MEGAPRO+ 15-IN-1 SCREWDRIVER • STAINLESS STEEL

- Nickel plated bits and stainless steel shaft for a maximum corrosion resistance.
- Great for marine applications, high humidity environments and outdoors.

#### Fully Loaded Driver

Description	Part #	Qty
Stainless Steel	37285	1

#### Replacement Bits

Description	Part #	Qty
T10-T15 Star Bit*	40021NP	1
T20-T25 Star Bit*	40022NP	1
#0 & #3 Phillips*	40003NP	1
#1 & #2 Phillips*	40004NP	1
#0 & #3 Square Drive*	40005NP	1
#1 & #2 Square Drive*	40006NP	1
#4 & #6 Slotted Drive*	40007NP	1

\*Driver comes packed with bits.

### MEGAPRO+ QUICK CHANGE SCREWDRIVER

Description	Part #	Qty
Orange Driver Fully Loaded	37150	1
#0 & #3 Square Drive*	40012	1
#1 & #2 Square Drive*	40013	1
#0 & #3 Phillips*	40014	1
#1 & #2 Phillips*	40015	1
#4 & #6 Slot*	40016	1
T10 & T15 Star*	40017	1
T20 & T25 Star*	40018	1
6" Driver Extension	40019	1
¼" Socket Adapter	40020	1
6-32 Hex Shank Power Tap**	68036 ★	1
8-32 Hex Shank Power Tap**	68038 ★	1
10-24 Hex Shank Power Tap**	68040 ★	1
10-32 Hex Shank Power Tap**	68044 ★	1
¼-20 Hex Shank Power Tap**	68046 ★	1
Hex Shank Power Tap Kit (6-32, 8-32, 10-24, 10-32, ¼-20)**	68096 ★	1

Bit Load						
Phillips	Square	Star	Slot			
#0	#0	T10	#4			
#3	#3	T15	#6			

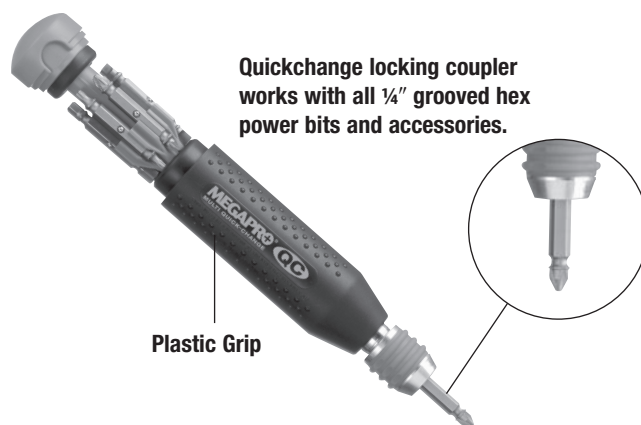

TOOLS

\*Driver comes packed with bits.

\*\*Hex Shank Taps are not warranted against breakage.

★ Made in USA

### MEGAPRO+ 16-IN-1 SCREWDRIVER • TAMPERPROOF

- Professional grade double-ended ¼" bits. Hardened to a 59 Rockwell.
- Spring-loaded, ball bearing bit assembly grasps bit snugly every time.
- Solid steel shaft runs the full length of the driver for balance and strength.
- Palm saving rotating cap covers easy access bit compartment.

Fully Loaded Driver		
Description	Part #	Qty
Grey	37011	1

Replacement Bits		
Description*	Part #	Qty
T10H-T15H Star Pin	69001	1
T20H-T25H Star Pin	69002	1
T27H-T30H Star Pin	69003	1
⅛-9/64 Socket Pin	69004	1
5/32-3/16 Socket Pin	69005	1
#6 & #8 Spanner	69006	1
#10 & #12 Spanner	69007	1
#1 & #2 Square Drive	40006	1

\*Driver comes packed with bits.



Bit Load								
Spanner	Square	Socket Pin	Star					
#6	#1	1/8	T10H					
#8	#2	5/32	T15H					
		9/64	T20H					
		3/16	T25H					
			T27H					
			T30H					

**Don't forget Tamperproof Screws.**  
See pages 46-49 for a complete guide.

See page 139 for our 29-in-1 Tamperproof Driver Bit Kit.

### 6-IN-1 ECONOMY SCREWDRIVER • QUICK CHANGE



- Quick change bit system with double-ended shaft and bits.
- Ends of shaft serve as two hex drivers.
- Ergonomic handle is comfortable and provides a good gripping surface.

**Free Counter Display with 18 Unit Minimum Purchase!**

Bit Load	Color	Part #	Box Qty
Phillips: #1, #2 Slotted: ¼", ⅜" Hex: ¼", ⅝"	Orange	<b>37014</b>	18
Phillips: #2 Slotted: ¼" Hex: ¼", ⅝" Square Drive: #1, #2	Red	<b>37016</b>	18

TOOLS

### 13-IN-1 RATCHETING SCREWDRIVER



- Cushion grip
- Retractable bit cartridge
- Palm saver cap

Bit Load	Color	Part #	Qty
Phillips: #0, #1, #2, #3 Slotted: #4, #6 Square Drive: #1, #2 TORX: #10, #15, #20, #25	Red and Black	<b>37020</b>	1

### 14-IN-1 HVAC SCREWDRIVER



- Plastic grip
- Alloy Steel Shaft
- Palm saver cap
- Easy guide collar
- Retractable bit cartridge

Bit Load	Color	Part #	Qty
Phillips: #0, #1, #2, #3 Slotted: #3, #4, #5, #5.5, #6 Square Awl: Valve Stem	Blue	<b>37021</b>	1

### 15-IN-1 TAMPERPROOF 2 SCREWDRIVER



- Plastic grip
- Alloy Steel Shaft
- Palm saver cap
- Easy guide collar
- Retractable bit cartridge

Bit Load	Color	Part #	Qty
Tri-Wing: #2, #3, #4, #5 TORX-Plus TR: #10, #15, #20, #25, #27, #30 TORX-Set: #4, #6, #8, #10	Red	<b>37022</b>	1

## 15-IN-1 SHAFTLOK 2 SCREWDRIVER

- Plastic grip
- Easy guide collar
- Palm saver cap
- Retractable bit cartridge

Bit Load	Color	Part #	Qty
Phillips: #0, #3 Slotted: #4, #6 Square Drive: #0, #1, #2, #3 TORX: #10, #15, #20, #25	Yellow	<b>37023</b>	1



## SPANNER DRIVE & UN-DO-IT TOOL

Description	Size	Part #	Unit	Std Pk
Spanner (Snake Eyes) Screwdriver, Plastic Grip	#6	<b>30006TP</b> ★	1	10
Spanner (Snake Eyes) Screwdriver, Plastic Grip	#8	<b>30008TP</b> ★	1	10
Spanner (Snake Eyes) Screwdriver, Plastic Grip	#10	<b>30010TP</b> ★	1	10
Spanner (Snake Eyes) Screwdriver, Plastic Grip	#12	<b>30012TP</b> ★	1	10
Spanner (Snake Eyes) Screwdriver, Plastic Grip	#14	<b>30014TP</b> ★	1	10
One Way Un-Do-It Tool	#6-8	<b>31206</b> ★	1	10
One Way Un-Do-It Tool	#10-12	<b>31210</b> ★	1	10
One Way Un-Do-It Tool	#14	<b>31214</b>	1	10

★ Made in USA

See Tamperproof Screws  
pages 46-49

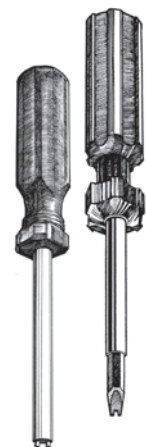

TOOLS

## SQUARE DRIVE SCREWDRIVERS

Description	Overall Length	Size	Screw Size	Color	Part #	Unit
Stubby, Plastic Grip	3"	#2	8, 9, 10	Red	<b>30002</b>	1
Stubby, Plastic Grip	3"	#3	12, 14	Black	<b>30003</b>	1
Midget, Plastic Grip	6½"	#0	3, 4	Yellow	<b>31000</b>	1
Rubber Cushion Grip, Short	7½"	#1	5, 6, 7	Green	<b>35001</b>	1
Rubber Cushion Grip, Short	7½"	#2	8, 9, 10	Red	<b>35002</b>	1
Rubber Cushion Grip, Short	7½"	#3	12, 14	Black	<b>35003</b>	1
Rubber Cushion Grip, Long	10"	#1	5, 6, 7	Green	<b>34001</b>	1
Rubber Cushion Grip, Long	10"	#2	8, 9, 10	Red	<b>34002</b>	1
Rubber Cushion Grip, Long	10"	#3	12, 14	Black	<b>34003</b>	1



### SCREWDRIVERS & NUT DRIVERS

In this line of screwdrivers and nut drivers, the lightweight shafts are produced from the highest quality German chrome vanadium high alloy steel. The handles are constructed of a single material polypropylene compound to withstand physical abuse and chemicals. In addition, these screwdrivers have a black oxide tip to prevent any chrome from chipping off in electronic equipment.

Cully warrants that any fastening tool, defective in material or workmanship, will be replaced without charge.



See Cully Screwdriver Counter display on page 282.

TOOLS

Description	Size	Part #	Unit	Std Pk
Phillips Screwdriver, Plastic Grip	1 x 3"	37100	1	6
Phillips Screwdriver, Plastic Grip	2 x 4"	37101	1	6
Slotted Screwdriver, Plastic Grip	3/16 x 4"	37103	1	6
Slotted Screwdriver, Plastic Grip	1/4 x 4"	37104	1	6
Slotted Screwdriver, Plastic Grip	5/16 x 6"	37105	1	6
Cabinet Screwdriver, Plastic Grip	3/16 x 6"	37107	1	6
Cabinet Screwdriver, Plastic Grip	1/4 x 4"	37108	1	6
Cabinet Screwdriver, Plastic Grip	1/4 x 6"	37109	1	6
Square Screwdriver, Plastic Grip	2 x 4"	37111	1	6
Square Screwdriver, Plastic Grip	3 x 4"	37112	1	6
Phillips Screwdriver – Insulated (1000 Volt), Plastic Grip	1 x 3"	37113	1	6
Phillips Screwdriver – Insulated (1000 Volt), Plastic Grip	2 x 4"	37114	1	6
Slotted Screwdriver – Insulated (1000 Volt), Plastic Grip	5/32 x 4"	37115	1	6
Slotted Screwdriver – Insulated (1000 Volt), Plastic Grip	1/4 x 6"	37116	1	6
Screwdriver Set – 37100, 37101, 37104, 37105, 37107, 37108, 37109	7 Piece	37123	1	1
Nut Driver	3/16 x 3"	37117	1	6
Nut Driver	1/4 x 3"	37118	1	6
Nut Driver	5/16 x 3"	37119	1	6
Nut Driver	3/8 x 3"	37120	1	6
Nut Driver	7/16 x 3"	37121	1	6
Nut Driver	1/2 x 3"	37122	1	6
Nut Driver Set – 37117, 37118, 37119, 37120, 37121, 37122	6 Piece	37124	1	1

### TAMPERPROOF KIT • 29-IN-1 DRIVER KIT

- 29 piece assortment of security bits includes star pin, socket pin, tri-wing, torq-set bit, square drive and spanner bit.
- Features a magnetic hand driver with storage case.
- Includes a magnetic holder for power driving!

This is one of the most complete tamper-proof screwdriver kits available anywhere with all of the most common and many of the rarest bits.



37009

Description	Size	Part #	Qty
29-In-1 Driver TamperProof Kit	—	<b>37009</b>	1
Socket Adapter	1"	<b>92600</b> ★	1
Magnetic Bit Holder	3"	<b>92602</b> ★	1

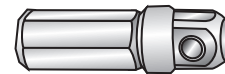



92600





92602

Spanner Bit 	
Size	Part #
#6	<b>31106</b> ★
#8	<b>31108</b> ★
#10	<b>31110</b> ★

Star Pin 	
Size	Part #
T-8H	<b>38983</b> ★
T-9H	<b>38984</b> ★
T-10H	<b>38985</b> ★
T-15H	<b>38988</b> ★
T-20H	<b>38990</b> ★
T-25H	<b>38992</b> ★
T-27H	<b>38994</b> ★
T-30H	<b>38996</b> ★
T-40H	<b>38998</b> ★

Tri-Wing 	
Size	Part #
#1	<b>38705</b> ★

Pozi Drive 	
Size	Part #
#1	<b>92500</b> ★

Socket Pin 	
Size	Part #
1/8"	<b>92706</b> ★
9/64"	<b>92707</b> ★
5/32"	<b>92709</b> ★
3/16"	<b>92710</b> ★
7/32"	<b>92711</b> ★
1/4"	<b>92718</b> ★
5/16"	<b>92720</b> ★

★ Made in USA

**Don't forget  
Tamperproof Screws.  
See pages 46-49.  
See page 135 for our 16-in-1  
Tamperproof Screwdriver.**

TOOLS

## DIAL-A-BIT KIT • SLOTTED, PHILLIPS & SQUARE DRIVE



- Includes a magnetic bit holder for power driving.

- Magnetic bit holder inserts into star hole at top of the bit case to become a screwdriver handle.

Description	Part #	Qty
10 Piece Kit	<b>39917</b> ★	1

Description	Part #
¼" Magnetic Bit Holder	<b>92602</b> ★

Slotted	
Size	Part #
#6	<b>38648</b>
#8	<b>38561</b> ★
#10	<b>38661</b> ★

★ Made in USA

Phillips	
Size	Part #
#1	<b>38401</b>
#2	<b>38501</b>
#3	<b>38601</b> ★

Square	
Size	Part #
#1	<b>38101</b>
#2	<b>38201</b>
#3	<b>38301</b>

TOOLS

## DRIVER BIT ACCESSORIES



Description	Overall Length	Part #	Unit
Magnetic Bit Holder	¼ x 3"	<b>39018</b>	1



Description	Part #	Unit
Double Ended Power Bit: #2 Square Drive, #2 Phillips	<b>38215</b>	1
Double Ended Power Bit: Bucket O' Bits	<b>38222</b>	125



Description	Part #	Unit
Magnetizer/Demagnetizer	<b>40010</b>	1

## QUICK CHANGE DRILL ADAPTER

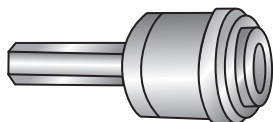

- Turns a standard drill into a keyless chuck for 2"+ longer power bits.

- Can also be used with hex shank drill bits (page 155).

Description	Part #	Unit
Quick Change Drill Adapter	<b>39020</b> ★	1

★ Made in USA



## SQUARE DRIVE HEX POWER BITS • 1/4" HEX SHANK

			Plastic Bag	5 Pk Clamshell	Bucket O' Bits			
Size	Length	Screw Size	Part #	Qty	Part #	Qty	Part #	Jar Qty
#0	1	#4	38001	1	38201-5	5	—	—
	2		38002	1	38202-5	5	—	—
	3		38003	1	38203-5	5	—	—
#1	1	#5-6	38101	1	38301-5	5	—	—
	2		38102	1	38302-5	5	—	—
	3		38103	1	▲	—	—	—
	4		38104	1	▲	—	—	—
	6		38106	1	▲	—	—	—
	#2		1	#8-10	38201	1	▲	—
2		38202	1		▲	—	38220	125
3		38203	1		▲	—	—	—
4		38204	1		▲	—	—	—
6		38206	1		▲	—	—	—
8		38208	1		▲	—	—	—
10		38210	1		▲	—	—	—
12		38212	1		▲	—	—	—
#3	1	#12-14	38301	1	▲	—	—	—
	2		38302	1	▲	—	—	—
	3		38303	1	▲	—	—	—
	4		38304	1	▲	—	—	—
	6		38306	1	▲	—	—	—
	8		38308	1	▲	—	—	—

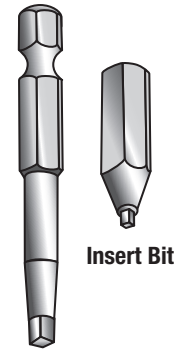

Hex Power Bit

Insert Bit

- All bits 19" length are insert bits. All bits over 19" length are sold as hex power bits.

## PHILLIPS HEX POWER BITS • 1/4" HEX SHANK

			Plastic Bag	5 Pk Clamshell	Bucket O' Bits			
Size	Length		Part #	Qty	Part #	Qty	Part #	Jar Qty
#1	1		38401	1	▲	—	—	—
	2		38402	1	▲	—	—	—
	3		38403	1	▲	—	—	—
	4		38404	1	▲	—	—	—
	6		38406	1	▲	—	—	—
#2	1		38501	1	38501-5	5	38500	250
	2		38502	1	38502-5	5	38520	125
	3		38503	1	38503-5	5	—	—
	4		38504	1	▲	—	—	—
	6		38506	1	▲	—	—	—
#3	1		38601 ★	1	▲	—	—	—
	2		38602	1	38602-5	5	—	—
	3		38603 ★	1	▲	—	—	—
	4		38604 ★	1	▲	—	—	—
	6		38606 ★	1	▲	—	—	—

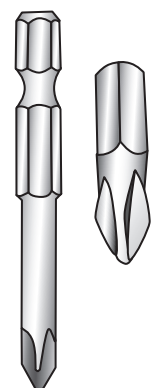

▲ Contact customer service for gravity feed jar availability.

★ Made in USA

## SLOTTED HEX POWER BITS • 1/4" HEX SHANK



		Plastic Bag	
Size	Length	Part #	Qty
#6-7	2	<b>38642</b> ★	1
#8-10	1	<b>38561</b>	1
	2	<b>38562</b>	1
	3	<b>38563</b>	1
	4	<b>38564</b>	1
#10-12	1	<b>38661</b>	1
	2	<b>38662</b>	1

★ Made in USA

TOOLS

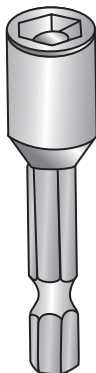

## HEX DRIVER BITS • MAGNETIC





			Plastic Bag	3 Pk Clamshell	Bucket O' Bits		
Size	Length	Screw Size	Part #	Qty	Part #	Part #	Jar Qty
1/4	1 3/4	#6-8	<b>39004</b>	1	<b>39004-5</b>	<b>39104</b>	50
	3		<b>39014</b>	1	<b>39014-5</b>	<b>39114</b>	25
	4		<b>39024</b> ★	1	▲	—	—
	6		<b>39034</b> ★	1	▲	—	—
5/16	1 3/4	#10-12	<b>39005</b>	1	<b>39005-5</b>	<b>39105</b>	50
	2 1/16		<b>39015</b>	1	<b>39015-5</b>	<b>39115</b>	25
	4		<b>39025</b> ★	1	▲	—	—
	6		<b>39035</b> ★	1	▲	—	—
3/8	1 3/4	#14	<b>39006</b>	1	▲	<b>39106</b>	50
	3		<b>39016</b>	1	▲	—	—
	4		<b>39026</b> ★	1	▲	—	—
	6		<b>39036</b> ★	1	▲	—	—



★ Made in USA



## TAMPERPROOF INSERT BITS • STAR, SPANNER & SOCKET PIN

 Star Pin 			
Size	Shank Size	Part #	Qty
T-8H	¼ Hex	<b>38983</b> ★	1
T-9H	¼ Hex	<b>38984</b> ★	1
T-10H	¼ Hex	<b>38985</b> ★	1
T-15H	¼ Hex	<b>38988</b> ★	1
T-20H	¼ Hex	<b>38990</b> ★	1
T-25H	¼ Hex	<b>38992</b> ★	1
T-27H	¼ Hex	<b>38994</b> ★	1
T-30H	¼ Hex	<b>38996</b> ★	1
T-40H	¼ Hex	<b>38998</b> ★	1
T-50H	¼ Hex	<b>38999</b>	1

 Tri-Wing Bits 				
Size	Length	Shank Size	Part #	Qty
#4	1	¼ Hex	<b>38704</b> ★	1
#5	1	¼ Hex	<b>38705</b> ★	1

See Tamperproof Screws  
pages 46-49

 Spanner Head 				
Size	Length	Shank Size	Part #	Qty
#6	1	¼ Hex	<b>31106</b> ★	1
#8	1	¼ Hex	<b>31108</b> ★	1
#10	1	¼ Hex	<b>31110</b> ★	1
#12	1	⅝ Hex	<b>31112</b> ★	1
#14	1	⅝ Hex	<b>31114</b>	1

 Socket Pin 			
Size	Shank Size	Part #	Qty
⅛	¼ Hex	<b>92706</b> ★	1
⅙	¼ Hex	<b>92707</b> ★	1
⅕	¼ Hex	<b>92709</b> ★	1
⅜	¼ Hex	<b>92710</b> ★	1
⅜	¼ Hex	<b>92711</b> ★	1
¼	¼ Hex	<b>92718</b> ★	1
⅜	¼ Hex	<b>92720</b> ★	1

★ Made in USA

TOOLS

### HIGH SPEED JOBBER DRILLS • 118° POINT • STEEL



- Made from high speed tool steel.
- Polished flute for fast chip removal.
- 118° point, the economical choice.
- See page 283 for display.

Size	Part #	Pkg Qty
1/64	<b>91597</b>	12
1/32	<b>91599</b> ★	12
3/64	<b>91600</b> ★	12
1/16	<b>91601</b> *	12
5/64	<b>91602</b> *	12
3/32	<b>91603</b> *	12
7/64	<b>91604</b> *	12
1/8	<b>91605</b> *	12
9/64	<b>91606</b> *	12
5/32	<b>91607</b> *	12
11/64	<b>91608</b> *	12
3/16	<b>91609</b> *	12
13/64	<b>91610</b> *	12
7/32	<b>91611</b> *	12
15/64	<b>91612</b> *	12
1/4	<b>91613</b> *	12
17/64	<b>91614</b> *	12
9/32	<b>91615</b> *	12

Size	Part #	Pkg Qty
19/64	<b>91616</b>	6
5/16	<b>91617</b> *	6
21/64	<b>91618</b> *	6
11/32	<b>91619</b> *	6
23/64	<b>91620</b> *	6
3/8	<b>91621</b> *	6
25/64	<b>91622</b> *	6
13/32	<b>91623</b> *	6
27/64	<b>91624</b> *	6
7/16	<b>91625</b> *	6
29/64	<b>91626</b> *	6
15/32	<b>91627</b> *	6
31/64	<b>91628</b> *	6
1/2	<b>91629</b> *	6
#7	<b>91707</b> ★	12
#25	<b>91725</b> ★	12
#29	<b>91729</b> ★	12

★ Made in USA

\*To set up display (Part #91808) order one package of each asterisked item.

#### 118° Metal Index Set

Size	Part #	Number of Pieces	Pkg Qty
1/16-1/4 x 64ths	<b>91801</b>	13	1
1/16-1/2 x 32nds	<b>91802</b>	15	1
1/16-3/8 x 64ths	<b>91804</b>	21	1
1/16-1/2 x 64ths	<b>91806</b>	29	1

## HIGH SPEED JOBBER DRILLS • 135° POINT • STEEL

- 135° split point is self-centering, reducing thrust.
- Better performance for just a few cents more than a 118° point.



Size	Part #	Pkg Qty
1/16	<b>91901</b>	12
5/64	<b>91902</b>	12
3/32	<b>91903</b>	12
7/64	<b>91904</b>	12
1/8	<b>91905</b>	12
9/64	<b>91906</b>	12
5/32	<b>91907</b>	12
11/64	<b>91908</b>	12
3/16	<b>91909</b>	12
13/64	<b>91910</b>	12
7/32	<b>91911</b>	12
15/64	<b>91912</b>	12
1/4	<b>91913</b>	12
17/64	<b>91914</b>	12
9/32	<b>91915</b>	12

Size	Part #	Pkg Qty
19/64	<b>91916</b>	6
5/16	<b>91917</b>	6
21/64	<b>91918</b>	6
11/32	<b>91919</b>	6
23/64	<b>91920</b>	6
3/8	<b>91921</b>	6
25/64	<b>91922</b>	6
13/32	<b>91923</b>	6
27/64	<b>91924</b>	6
7/16	<b>91925</b>	6
29/64	<b>91926</b>	6
15/32	<b>91927</b>	6
31/64	<b>91928</b>	6
1/2	<b>91929</b>	6

118° Metal Index Set			
Size	Part #	Number of Pieces	Pkg Qty
1/16-1/4 x 64ths	<b>91945</b>	13	1
1/16-1/2 x 64ths	<b>91949</b>	29	1

TOOLS

### TRINADO HEAVY-DUTY DRILLS • 135° POINT



Size	Description	Part #	Qty
1/16	Straight Shank	<b>33304</b> ★	12
5/64	Straight Shank	<b>33305</b> ★	12
3/32	Straight Shank	<b>33306</b> ★	12
7/64	Straight Shank	<b>33307</b> ★	12
1/8	Straight Shank	<b>33308</b> ★	12
9/64	Straight Shank	<b>33309</b> ★	12
5/32	Straight Shank	<b>33310</b> ★	12
11/64	Straight Shank	<b>33311</b> ★	12
3/16	Straight Shank	<b>33312</b> ★	12

★ Made in USA

Size	Description	Part #	Qty
13/64	3 Flat Shank	<b>33313</b> ★	12
7/32	3 Flat Shank	<b>33314</b> ★	12
15/64	3 Flat Shank	<b>33315</b> ★	12
1/4	3 Flat Shank	<b>33316</b> ★	12
17/64	3 Flat Shank	<b>33317</b> ★	12
9/32	3 Flat Shank	<b>33318</b> ★	12
19/64	3 Flat Shank	<b>33319</b> ★	12
5/16	3 Flat Shank	<b>33320</b> ★	6
21/64	3 Flat Shank	<b>33321</b> ★	6
11/32	3 Flat Shank	<b>33322</b> ★	6
23/64	3 Flat Shank	<b>33323</b> ★	6
3/8	3 Flat Shank	<b>33324</b> ★	6
25/64	3 Flat Shank	<b>33325</b> ★	6
13/32	3 Flat Shank	<b>33326</b> ★	6
27/64	3 Flat Shank	<b>92627</b> ★	6
7/16	3 Flat Shank	<b>92628</b> ★	6
29/64	3 Flat Shank	<b>92629</b> ★	6
15/32	3 Flat Shank	<b>92630</b> ★	6
31/64	3 Flat Shank	<b>92631</b> ★	6
1/2	3 Flat Shank	<b>92632</b> ★	6

TOOLS

### TRINADO HEAVY-DUTY DRILLS • METAL INDEX SET



- Black and bronze oxide surface treatments reduce friction.
- M7 industrial steel withstands high temperatures, maintains sharpness.
- Excellent for drilling in stainless and high carbon steels.

Size Range	No. Pcs	Part #	Qty
1/16–1/4 x 32nds	13	<b>33333</b> ★	1
1/16–3/8 x 64ths	21	<b>33335</b> ★	1
1/16–1/2 x 64ths	29	<b>33336</b> ★	1

★ Made in USA

### DIAL-A-DRILL SET • HANDY DISPENSER KIT

- All the most popular sizes in a convenient rotating case!

Size Range	No. Pcs	Part #	Qty
1/16–1/4 x 64ths	13	<b>91809</b>	1



### HEX DRILL SET • 135° SPLIT POINTS WITH HEX SHANKS • 7 PIECES

- Use a Quick-Change Drill Adapter (#39020) with hex shank drills to speed up interchange without needing to use drill chuck.

Size Range	No. Pcs	Part #	Qty
1/16–3/32–1/8–5/32– 3/16–7/32–1/4	7	<b>45432</b> ★	1

★ Made in USA

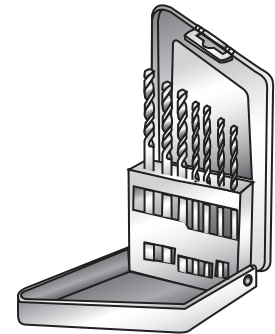

TOOLS

### SPECIAL DRILL SETS • COBALT & TITANIUM DRILLS

Description	No. Pcs	Part #	Qty
Cobalt Drill Set (Gold) 1/16–1/4 x 64ths	13	<b>91805</b>	1
Titanium Drill Set (Yellow) 1/16–1/4 x 64ths	13	<b>91807</b>	1

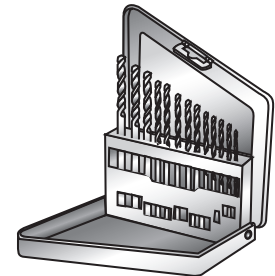

### STRAIGHT SHANK CARBIDE DRILL BITS • ROTARY ONLY



- Straight shank design. Our most economical carbide bits.
- Fits any portable rotary drill or drill press – up to 1000 RPM.
- The right solution for drilling holes in tile, brick, block or cement.

★ Made in USA

Hole Size	Length	Part #	Pkg Qty
3/16	4	59904 ★	1
1/4	4	59906 ★	1
1/4	6	59908	1
5/16	4	59910	1
5/16	6	59912	1
3/8	4	59914	1
3/8	6	59916	1
1/2	4	59918	1
1/2	6	59920	1
5/8	6	59922	1

### ROTARY/PERCUSSION CARBIDE DRILL BITS • RELTON™ QUALITY



- Highest quality tungsten carbide tips.
- Packaged in high-visibility plastic tubes.
- Exclusive RamTip™ design for a secure fit in rotary and percussion drills.
- Uniform cutting angles provide sharp, clean holes in concrete, brick or block.

★ Made in USA

Hole Size	Length	Part #	Pkg Qty
1/8	3	59720 ★	1
3/16	4	59722* ★	1
1/4	4	59724* ★	1
1/4	6	59726 ★	1
5/16	4	59728* ★	1
5/16	6	59730 ★	1
3/8	4	59732 ★	1
3/8	6	59734* ★	1
1/2	6	59736* ★	1
5/8	6	59738 ★	1
3/4	6	59740 ★	1

\*See display offer on page 283.

### SDS ROTARY/HAMMER CARBIDE DRILL BITS • RELTON™ QUALITY



Hole Size	Length	Part #	Pkg Qty
3/16	4 1/2	59980 ★	1
1/4	4	59984 ★	1
1/4	6	59986* ★	1
1/4	12	59996 ★	1
5/16	6	59987 ★	1
3/8	6	59988* ★	1
3/8	12	59998 ★	1
1/2	6	59990* ★	1
1/2	12	59991 ★	1
5/8	8	59992* ★	1
3/4	8	59994 ★	1

\*See display offer on page 283.

★ Made in USA



### BELL HANGER BITS • WIRING INSTALLATIONS • HIGH SPEED

		 Plastic Bag		
Hole Size	Length	Part #	Pkg Qty	
1/4	12	82204	1	
5/16	12	82205	1	
3/8	12	82206	1	
7/16	12	82207	1	
1/2	12	82208	1	
3/16	18	82303	1	
1/4	18	82304	1	
5/16	18	82305	1	
3/8	18	82306	1	
7/16	18	82307	1	
1/2	18	82308	1	
1/4	24	82404	1	
5/16	24	82405	1	
3/8	24	82406	1	
1/2	24	82408	1	

- Heat treated steel bits for maximum strength and durability.
- Perfect for boring through wood, metal, plaster and particle board.
- Hole in head of bit for easy pulling of wire.



#### Installation

- Drill a hole through walls, ceiling or floor.
- Attach wire through the hole at the end of the bell hanger.
- Withdraw drill and pull wire through.

### FLEX SHANK DRILL BITS (FISH BITS) • SELF-FEED SCREW POINT

		 Plastic Bag		
Hole Size	Length	Part #	Pkg Qty	
3/8	54	92050	1	
1/2	54	92052	1	
9/16	54	92054	1	
3/4	54	92056	1	
3/8	72	92051	1	
1/2	72	92053	1	
9/16	72	92055	1	
3/4	72	92057	1	
Fish Bit Steering Guide		92058	1	

- Self-feeding screw point is brazed to a flexible spring steel shaft.
- Perfect for drilling holes and pulling wires and cables through walls, ceilings and floors.
- Steering guide bends and directs the fish bit in the right position.

#### Display:

- Free wall-mounted display with first time order of 8 bits. Please ask for part #95330 when placing order.



### ELECTRICIAN'S POWER BITS • SELF-FEEDING SCREW POINT

		 Plastic Bag		
Hole Size	Length	Hex Shank	Part #	Pkg Qty
5/8	8 1/2	5/16	80910	1
1 1/16	8 1/2	5/16	80911	1
3/4	8 1/2	5/16	80912	1
13/16	8 1/2	5/16	80913	1
7/8	8 1/2	5/16	80914	1
1	8 1/2	5/16	80916	1
1 1/8	8 1/2	5/16	80918	1
1 1/4	8 1/2	5/16	80920	1

- Single spur double twist drill with self-feeding screw point.

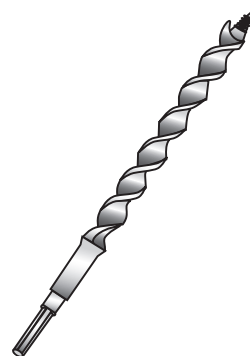

### 6" SHIP AUGER BITS • HEX SHANK • HEAT TREATED STEEL



- Single twist with self-feeding screw point cuts smoothly through wood.
- Super strong heat treated steel cuts through nails and other materials.
- Hollow center designed for fast flow of chips.
- Can be sharpened with a Cully auger bit sharpening file (Part #09382).

Hole Size	Length	Hex Shank	Part #	Pkg Qty
1/2	6	5/16	<b>80608</b>	1
9/16	6	7/16	<b>80609</b>	1
5/8	6	7/16	<b>80610</b>	1
3/4	6	7/16	<b>80612</b>	1
13/16	6	7/16	<b>80613</b>	1
7/8	6	7/16	<b>80614</b>	1
15/16	6	7/16	<b>80615</b>	1
1	6	7/16	<b>80616</b>	1
1 1/8	6	7/16	<b>80618</b>	1
1 1/4	6	7/16	<b>80620</b>	1
1 3/8	6	7/16	<b>80622</b>	1
1 1/2	6	7/16	<b>80624</b>	1

Same as Bell Hanger packaging.

### 17" SHIP AUGER BITS • HEX SHANK • HEAT TREATED STEEL



Hole Size	Length	Hex Shank	Part #	Pkg Qty
3/8	17	5/16	<b>81806</b>	1
7/16	17	5/16	<b>81807</b>	1
1/2	17	5/16	<b>81808</b>	1
9/16	17	7/16	<b>81809</b>	1
5/8	17	7/16	<b>81810</b>	1
11/16	17	7/16	<b>81811</b>	1
3/4	17	7/16	<b>81812</b>	1
13/16	17	7/16	<b>81813</b>	1
7/8	17	7/16	<b>81814</b>	1
15/16	17	7/16	<b>81815</b>	1
1	17	7/16	<b>81816</b>	1
1 1/16	17	7/16	<b>81817</b>	1
1 1/8	17	7/16	<b>81818</b>	1
1 1/4	17	7/16	<b>81820</b>	1
1 3/8	17	7/16	<b>81822</b>	1
1 1/2	17	7/16	<b>81824</b>	1

Same as Bell Hanger packaging.

### AUGER BIT EXTENSIONS & SHARPENING FILE



- Heavy duty, features a double-set screw lock, adds 9 1/2" to 24" to your bits.

Description	Length	Hex Shank	Part #	Pkg Qty
Auger Bit Extension	9 1/2	7/16	<b>82009</b>	1
Auger Bit Extension	12	7/16	<b>82012</b>	1
Auger Bit Extension	18	7/16	<b>82018</b>	1
Auger Bit Extension	24	7/16	<b>82024</b>	1
Auger Sharpening File	7	—	<b>09382</b>	1

Same as Bell Hanger packaging.

### SAWTOOTH SELF-FEEDING BITS • THREE MILLED FLATS

Hole Size	Length	Part #	Pkg Qty
1 3/8	5	86922 ★	1
1 1/2	5	86924 ★	1
1 3/4	5	86928 ★	1
2 1/8	5	86934 ★	1
2 9/16	5	86941 ★	1
3 5/8	5	86958 ★	1

★ Made in USA

- Open design wisks away wood chips.
- Fine thread screw point provides excellent control.
- Tapered for easy removal.

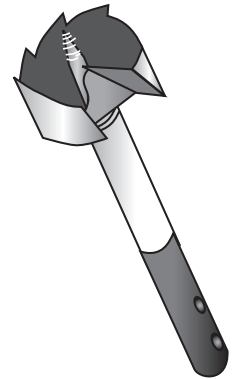

### SPEEDBOR 2000™ WOOD BITS • IRWIN 2000

Hole Size	Length	Part #	Pkg Qty
1/4	6	85004 ★	1
5/16	6	85005 ★	1
3/8	6	85006 ★	1
7/16	6	85007 ★	1
1/2	6	85008 ★	1
9/16	6	85009 ★	1
5/8	6	85010 ★	1
11/16	6	85011 ★	1
3/4	6	85012 ★	1
13/16	6	85013 ★	1
7/8	6	85014 ★	1
15/16	6	85015 ★	1
1	6	85016 ★	1
1 1/8	6	85018 ★	1
1 1/4	6	85020 ★	1
1 3/8	6	85022 ★	1
1 1/2	6	85024 ★	1
12" Extension		88602 ★	1
6" Extension		88703 ★	1

★ Made in USA

- Extended spurs scribe the hole for faster chip clearance.
- Precision-ground shanks run true with no run-out or wobble.
- Fits 1/4" and larger power drives.
- Micro-groove point moves quickly through hardwood, softwood, plywood and drywall.

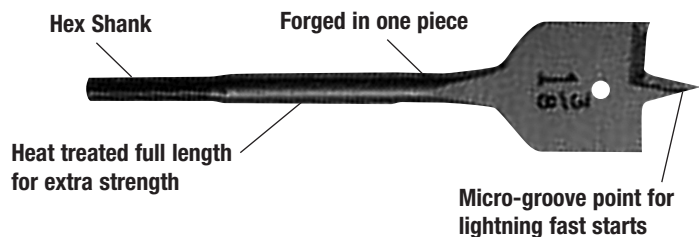

### STEP DRILLS • 2-FLUTE SPLIT TIP DESIGN • HIGH SPEED STEEL

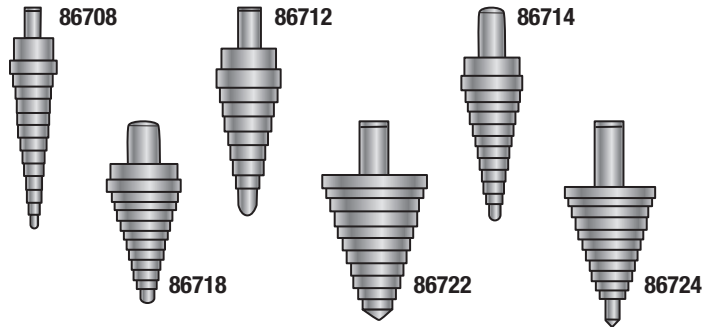

- Will drill through 10 gauge mild steel or stainless steel.
- Three flats shank for non-slip grip.
- Self-drilling. Requires no pre-punching.

Applications		
• Metal Studs	• Switchboxes	• Junction Boxes
• Lighting	• Fixtures	

Hole Size Range	Increments	Number of Steps	Shank Size	Step Thickness	Part #	Pkg Qty
1/8–1/2	1/32	13	1/4	1/8	<b>86708</b>	1
1/4–3/4	1/16	9	3/8	1/8	<b>86712</b>	1
3/16–7/8	1/16	12	3/8	1/8	<b>86714</b>	1
7/16–1 1/8	1/16	12	3/8	1/8	<b>86718</b>	1
3/4–1 3/8	1/16	11	3/8	1/8	<b>86722</b>	1
1/4–1 1/2	1/16	11	3/8	1/8	<b>86724</b>	1

### CONE BITS • 2-FLUTE DESIGN • 3 FLATS SHANK

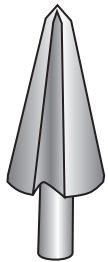

- Quickly creates a pilot hole for knockout applications.
- Three flats shank fits securely in chuck for a sure grip.
- Double fluted cone cuts clean, concentric holes.

Hole Size Range	Part #	Pkg Qty
3/8–7/8	<b>86814</b>	1

### HOLE SAW ARBORS & PILOT DRILLS

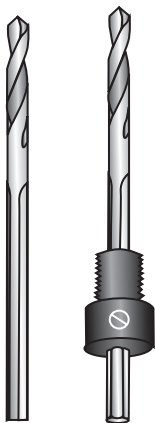

Description	Shank Size	Thread Size	Drill #	Chuck Size	Arbor Ext.	MFG #	Part #	Qty
Arbors	1/4 Round	1/2-20	MPD4	1/4	—	M24K	<b>86540*</b> ★	1
Arbors	1/4 Hex	1/2-20	MPD4S	1/4	—	M24	<b>86544*</b> ★	1
Arbors	3/8 Hex	1/2-20	MPD4S	3/8	—	M34	<b>86554*</b> ★	1
Arbors	7/16 Hex	1/2-20	MPD4	1/2	ME12	M44K	<b>86556*</b> ★	1
Arbors	7/16 Hex	1/2-20	MPD4	1/2	ME12	M44	<b>86558*</b> ★	1
Arbors	7/16 Hex	5/8-18	MPD4	1/2	ME12	M45P	<b>86545*</b> ★	1
Arbors	3/8 Hex	5/8-18	MPD4S	3/8	—	M35PS	<b>86560*</b> ★	1
Arbors	5/8 Hex	5/8-18	MPD4	3/4	—	M55P	<b>86566*</b> ★	1
1/4 x 4 1/2 Pilot Drill	—	—	—	—	—	MPD4	<b>86511</b> ★	1
1/4 x 2 3/4 (M24) Pilot Drill	—	—	—	—	—	MPD4S	<b>86514</b> ★	1
12" Arbor Extension	—	—	—	—	—	ME12	<b>86512</b> ★	1

\*Includes a 1/4" pilot drill.

★ Made in USA

### VARIABLE PITCH HOLE SAWS • BI-METAL • 4–6 PITCH

- Variable pitch (4 and 6 teeth per inch). Cuts 45% faster than a conventional 6-pitch saw.
- 1½" cutting depth – Designed for use in wood, plastic, steel, tin, aluminum and fiberglass.

Hole Size	Arbor #	MFG #	Part #	Qty	
⅝	M24	AV09	<b>86209</b> ★	1	
¾		AV12	<b>86212</b> ★	1	
⅞		AV14	<b>86214</b> ★	1	
1		M24K	AV16	<b>86216</b> ★	1
1⅛		M44	AV17	<b>86217</b> ★	1
1⅜		M44K	AV18	<b>86218</b> ★	1
1⅝		AV19	<b>86219</b> ★	1	
1¾		M35PS	AV20	<b>86220</b> ★	1
1⅞			AV22	<b>86222</b> ★	1
1½	AV24		<b>86224</b> ★	1	
1⅝	M45		AV26	<b>86226</b> ★	1
1¾	M45P		AV28	<b>86228</b> ★	1
2	M55		AV32	<b>86232</b> ★	1
2⅛	M44K		AV34	<b>86234</b> ★	1
2¼	AV36		<b>86236</b> ★	1	
2⅝	AV38		<b>86238</b> ★	1	

Hole Size	Arbor #	MFG #	Part #	Qty
2½	M45P M55P M44K	AV40	<b>86240</b> ★	1
2⅝		AV42	<b>86242</b> ★	1
2¾		AV44	<b>86244</b> ★	1
2⅞		AV46	<b>86246</b> ★	1
3		AV48	<b>86248</b> ★	1
3¼		AV52	<b>86252</b> ★	1
3⅝		AV54	<b>86254</b> ★	1
3½		AV56	<b>86256</b> ★	1
3⅞		AV58	<b>86258</b> ★	1
3¾		AV60	<b>86260</b> ★	1
4		AV64	<b>86264</b> ★	1
4⅛		AV66	<b>86266</b> ★	1
4¼		AV68	<b>86268</b> ★	1
4⅜		AV70	<b>86270</b> ★	1
4½		AV72	<b>86272</b> ★	1
4¾		AV76	<b>86276</b> ★	1
5		AV80	<b>86280</b> ★	1
5¼		AV84	<b>86284</b> ★	1
5½		AV88	<b>86288</b> ★	1
5¾		AV92	<b>86292</b> ★	1
6	AV96	<b>86296</b> ★	1	
6⅝	AV98	<b>86298</b> ★	1	



Premium Morse Real McCoy (TA) Hole Saws with built-in arbors available by special order.

See display offer on page 283

TOOLS

★ Made in USA

### ELECTRICIAN'S HOLE SAW KIT

- Kit contains 6 of the most popular variable pitch hole saws.
- Packaged in a durable plastic carrying case.



Kits				
Part #	Description			
<b>86522</b> ★ (8 Piece Kit)	<b>Pipe Entrance Kit (AV02E)</b> For Pipe ½"–2"			
	⅞" Hole Saw	1⅜" Hole Saw	2" Hole Saw	M44 Arbor
	1⅞" Hole Saw	1¾" Hole Saw	2½" Hole Saw	M45P Arbor

★ Made in USA

### MASTER ELECTRICIAN'S HOLE SAW KIT



- Kit contains 10 of the most popular variable pitch hole saws.
- Includes two 7/16" hex arbors – 1/2-20 and 5/8-18 and a 1/4 round 1/2-20 arbor.



Part #	Description			
	<b>Pipe Entrance Kit (AV08E) – For Pipe 1/2"–4"</b>			
<b>86528</b> ★ (13 Piece Kit)	7/8" Hole Saw	2" Hole Saw	4 1/8" Hole Saw	M45P Arbor
	1 1/8" Hole Saw	2 1/2" Hole Saw	4 1/2" Hole Saw	
	1 3/8" Hole Saw	3" Hole Saw	M24K Arbor	
	1 3/4" Hole Saw	3 5/8" Hole Saw	M44 Arbor	

★ Made in USA

### MAINTENANCE HOLE SAW KIT • PLUMBERS & ELECTRICIANS

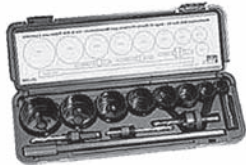

- Kit contains 9 plumbing and electrical sizes.
- Includes 12" arbor extension.
- The most versatile choice for electricians and plumbers working with 1/2" to 2" pipe and conduit.



Part #	Description			
	<b>Pipe Entrance Kit (AV100)</b> For Pipe 1/2"–2"			
<b>86530</b> ★ (13 Piece Kit)	3/4" Hole Saw	1 1/2" Hole Saw	2 1/2" Hole Saw	ME12 Ext
	7/8" Hole Saw	1 3/4" Hole Saw	M24K Arbor	
	1 1/8" Hole Saw	2" Hole Saw	M44 Arbor	
	1 3/8" Hole Saw	2 1/4" Hole Saw	M45P Arbor	

★ Made in USA

### CARBIDE GRIT HOLE SAWS



- The perfect choice for installing recessed lighting. Carbide cuts through ceiling tiles without catching.
- Outstanding for cutting through steel, copper and aluminum.
- Gulleted edge with 1 3/8" cutting depth (86302, 86303 and 86304 do not have a gulleted edge).
- Requires separate arbor (see below).

Hole Diameter	For Installing These Light Fixtures	Arbor #	MFG #	Part #
7/8"	—	<b>86545</b> ★ or <b>86556</b> ★	ATCG14	<b>86314</b> ★
1 1/8"	—		ATCG18	<b>86322</b> ★
1 3/8"	—		ATCG22	<b>86328</b> ★
1 3/4"	—		ATCG28	<b>86338</b> ★
3 5/8"	3-0 Outlet Boxes	<b>86545</b> ★ or <b>86556</b> ★	ATCG58	<b>86305</b> ★
4 1/8"	Capri, 4-0 Outlet Boxes		ATCG66	<b>86306</b> ★
4 3/8"	Capri, Halo, Juno, Marco		ATCG70	<b>86301</b> ★
6 3/8"	Capri, Halo		ATCG104	<b>86302</b> ★
6 5/8"	Juno, Progress		ATCG106	<b>86303</b> ★
6 7/8"	Capri, Lightolier, Lithonia, Progress, Prescolite, Marco		ATCG110	<b>86304</b> ★

#### Great For

- Cement Board
- Plaster • Drywall
- Stucco • Plywood
- Ceiling Tiles
- Acoustical Tiles

## CARBON STEEL TAPS • PLUG STYLE

- High speed steel stays sharp even after tapping hardened alloys.
- All taps are national coarse except 10-32 National Fine.

Carbon Steel Tap			Corresponding Drill		
Description	Part #	Pkg Qty	Drill Size	Part #	Qty
6-32	<b>68037</b>	5	#36	<b>91736</b>	12
8-32	<b>68039</b>	5	#29	<b>91729</b>	12
10-24	<b>68041</b>	5	#25	<b>91725</b>	12
10-32	<b>68042</b>	5	#21	<b>91721</b>	12
¼-20	<b>68047</b>	5	#7	<b>91707</b>	12
⅝-18	<b>68049</b>	5	"F"	<b>9170F</b>	12
⅜-16	<b>68080</b>	5	⅝"	<b>91617</b>	6
½-13	<b>68084</b>	5	⅔"	<b>91624</b>	12



## CARBON STEEL TAP WRENCHES • PLUG STYLE

Description	Part #	Qty
Tap Handle for 6-32 to ¼-20	<b>69902</b>	1
Tap Handle for ¼-20 to ½-13	<b>69904</b>	1

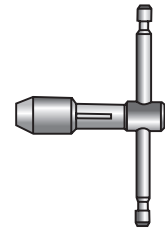

## CARBON STEEL TAPS & DRILL SET

- Essential kit for every electrical contractor.
- Contains the 6 most popular tap sizes with corresponding twist drills and universal T-Handle.

Part #	Description
	<b>Kits</b>
	<b>Tap &amp; Drill Bit Set</b>
<b>96042</b> ★ (13 Piece Kit)	Carbon Plug Taps: 4-40, 6-32, 8-32, 10-24, 10-32, ¼-20 (6 Pieces) High Speed Twist Drills: #43, #36, #29, #25, #21, #7 (6 Pieces) T-Handled Wrench (1 Piece)



★ Made in USA

## HEX SHANK TAPS

- Specially designed for the Quick Change Drill Adapter (page 140).
- Fits all hex shank power and hand tools.

Description	Part #	Qty
6-32 Hex Shank Power Tap	<b>68036</b> ★	6
8-32 Hex Shank Power Tap	<b>68038</b> ★	6
10-24 Hex Shank Power Tap	<b>68040</b> ★	6
10-32 Hex Shank Power Tap	<b>68044</b> ★	6
¼-20 Hex Shank Power Tap	<b>68046</b> ★	6
Hex Shank Power Tap Kit (Includes 6-32, 8-32, 10-24, 10-32, ¼-20)	<b>68096</b> ★	1



★ Made in USA

### SCREW EXTRACTOR & DRILL BIT SET



- Removes broken screws and bolts.
- Insert into pre-drilled hole and back out with a wrench. Broken part will dislodge.

Kits	
Part #	Description
<b>96046</b> ★ (10 Piece Kit)	<b>Screw Extractor Kit</b> Screw Extractors: #1, #2, #3, #4, #5 (5 Pieces) Twist Drills: 5/64, 7/64, 5/32, 1/4, 17/64 (5 Pieces)

★ Made in USA

### DAMAGED SCREW REMOVAL SET



- For phillips, slotted, star and square screws.
- Hardened steel bits for secure bit.
- 1/4" hex shank fits drills, sockets and screwdrivers.
- Sizes #1, #2 and #3 screw removers in handy storage case.

Description	Part #	Qty
3 Piece Damaged Screw Removal Set	<b>96047</b>	1

### DRYWALL JAB SAW



- Extra rigid 6" carbon steel blade.
- Sharp point for easy penetration.
- Ergonomic no slip handle.

Description	Part #	Qty
6" Drywall Jab Saw	<b>37450</b>	10



### HACKSAW BLADES • BI-METAL CONSTRUCTION

- Cuts wood, plastic or any machinable metal, including conduit, stainless steel tubing, angle iron and copper tubing.
- Tooth hardness RC 65-67.
- Outperforms leading hacksaw brands.

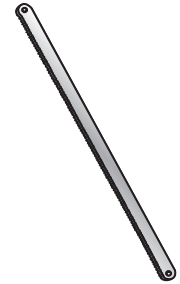

Description	Teeth/Inch	Part #	Pkg
12" x 1/2" W x .025"	18	<b>86618</b> ★	10
12" x 1/2" W x .025"	24	<b>86624</b> ★	10
12" x 1/2" W x .025"	32	<b>86632</b> ★	10

★ Made in USA

### HACKSAW FRAME • LIGHT WEIGHT • HIGH TENSION

- Locking screw design with multiple pin locations and tensioning handle.
- Standard or angled blade mounting.
- Stores blade or secures blade for job sawing.

Description	Part #	Qty
High-Tension Hacksaw Frame	<b>86640</b> ★	1

★ Made in USA



### RECIPROCATING SAW BLADES • BI-METAL • 1/2" SHANK

Length	Teeth/Inch	Use	Application	Part #	Pkg
4	14	Metal	1/8" Thick and Above	<b>86633</b> ★	5
6	14	Metal	1/8" Thick and Above	<b>86634</b> ★	5
4	18	Metal	18 Gauge to 1/8"	<b>86637</b> ★	5
6	18	Metal	18 Gauge to 1/8"	<b>86638</b> ★	5
4	24	Metal	18 Gauge and Under	<b>86641</b> ★	5
6	24	Metal	18 Gauge and Under	<b>86644</b> ★	5
8	10	Wood/Metal	All Woods, Plastic, Alum	<b>86650</b> ★	5
3 1/2	17	Wood/Metal	Scroll Cuts Wood, Alum	<b>86655</b> ★	5
6	5-7	Wood	Plaster w/Metal Lath	<b>86660</b> ★	5
12	5-7	Wood	Plasterboard	<b>86665</b> ★	5
6	6	Plaster	Sheetrock	<b>86670</b> ★	5

★ Made in USA

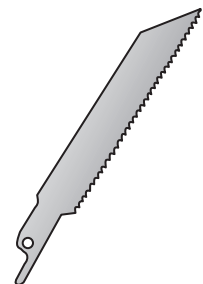

### PVC CABLE SAW

- Flexible handles allow cutting in hard to reach situations.
- Economy priced.

Description	Part #	Unit	Qty
PVC Cable Saw	<b>96260</b> ★	1	24

★ Made in USA

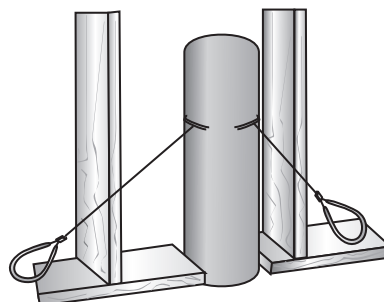

### ACCUSHARP® KNIFE SHARPENER



- Fast, effective results with twin blades set at optimal 21° cutting angle.
- Form fitted handle fits either hand safely and securely.
- Safe and easy to use with durable full sized knuckle guard.
- Tungsten carbide blades. Diamond-honed and precision formed with an RC of 97.
- Great for sharpening knives, shovels, garden tools and axes.
- See page 282 for display details.

Description	Part #	Case Qty
Accusharp® Knife Sharpener	<b>37400</b> ★	12
Accusharp® Knife Sharpener Camo	<b>37400C</b> ★	12
Replacement Blades (Set of 2)	<b>37404</b> ★	12

Can be ordered individually.

★ Made in USA

TOOLS

### QUICKBLADE™ • ERGONOMIC UTILITY KNIFE



- Spring loaded hinge.
- Packed with a straight blade.
- Locking knob is flush with knife handle and stays attached to knife.
- Counter display available at no additional charge with orders of 18.

Description	Part #	Qty
Autoload Utility Knife	<b>90214</b>	1
Ergonomic Utility Knife	<b>90215</b>	1
Straight Edge Blades	<b>90228</b> ★	5 Pk
Straight Edge Blades	<b>90229</b> ★	100 Pk

★ Made in USA

### TITAN™ FOLDING POCKET UTILITY KNIFE



- Change blade with the push of a button, no tools necessary.
- Folds compact for easy storage and portability.

- Blade locks in open position for safety.
- Uses standard utility blades.
- Belt clip included.

Description	Part #	Qty
Titan™ Folding Pocket Utility Knife	<b>37975</b>	1



**BONUS!**  
5 FREE blades in a handy dispenser!



Folds compact for safety

### SOG® Powerlock

#### 37304 (S60)

Scissors	Phillips Screwdriver	Small Screwdriver
Wire Cutter	¼" Drive	Medium Screwdriver
Plier/Gripper	Can Opener	Large Screwdriver
Crimper	Bottle Opener	
Wood Saw	Ruler	
½" Serrated Blade	Lanyard Ring	
3-Sided File		
Awl		



### SOG® Powerlock with V-Cutter

#### 37968 (S62)

V-Cutter	Wood Saw	Rulers
Crimper	Bottle Opener	Awl
Wire Cutter	½" Serrated Blade	Phillips Screwdriver
File	¼" Drive	
Lanyard Ring		
Plier/Gripper		
Can Opener		
Small/Medium/Large Screwdriver		



### SOG® Pocket Power Plier

#### 37308 (S44)

Needle Nose Plier	Lanyard Ring	Can/Bottle Opener
Wire Cutter	¼" Drive	Awl
Plier/Gripper	File	
½" Serrated Blade	Ruler	
Phillips Screwdriver		
Small/Large Screwdrivers		



### SOG® Paratool

#### 37301 (S31)

Plier/Gripper	Phillips Screwdriver	Lanyard Ring
Wire Cutter	Can Opener/ Small Screwdriver	Rulers
Serrated Blade	Bottle Opener/ Medium Screwdriver	Awl
Straight Blade		
3-Sided File		
Large Screwdriver		

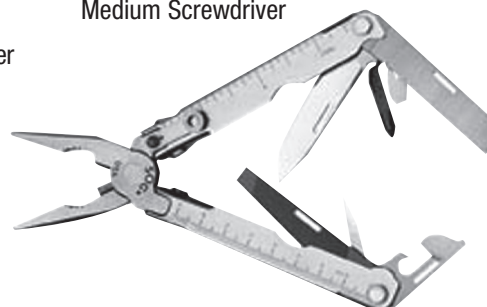

See page 282 for display details

### SOG® Paratool – Black Oxide

#### 37302 (B31)

Plier/Gripper	Phillips Screwdriver	Lanyard Ring
Wire Cutter	Can Opener/ Small Screwdriver	Rulers
Serrated Blade	Bottle Opener/ Medium Screwdriver	Awl
Straight Blade		
3-Sided File		
Large Screwdriver		



TOOLS



Flash I



Flash II

### SOG® Flash I

#### 5.75" Open • 2.5 x .090" Blade

The Flash I comes standard with glass-reinforced Zytel® handles and ½ serrated blades. Options include straight edge blade, black TiNi ½ serrated blade/clips/pivot, hard-anodized 6061-T6 aluminum handles.

- |                         |              |                    |
|-------------------------|--------------|--------------------|
| <b>37760</b> (FSA-7):   | • Stainless  | • Straight Blade   |
| <b>37770</b> (FSA-97):  | • Stainless  | • ½ Serrated Blade |
| <b>37771</b> (TFSA-97): | • Black TiNi | • ½ Serrated Blade |

### SOG® Flash II

#### 8" Open • 3.5 x .125" Blade

The Flash II (Partially Serrated) comes standard with glass-reinforced nylon (GRN) handle and ½ serrated blade. Also incorporates an additional safety lock that gives added security when the blade is closed.

- |                         |              |                    |
|-------------------------|--------------|--------------------|
| <b>37761</b> (FSA-8):   | • Stainless  | • Straight Blade   |
| <b>37769</b> (FSA-98):  | • Stainless  | • ½ Serrated Blade |
| <b>37772</b> (TFSA-98): | • Black TiNi | • ½ Serrated Blade |
| <b>37773</b> (DFSA-98): | • Camo TiNi  | • ½ Serrated Blade |

TOOLS



SOG Trident – Black TiNi



SOG Trident – Stainless



SOG Trident – Camo

### SOG® Trident

#### 8.5" Open • 3.75 x .125" Blade

The SOG® Trident uses a well-proven means of delivering a knife blade to the open position with S.A.T. (SOG® Assisted Technology™). Now using the patent pending Arc-Actuator™, the Trident locks stronger and releases easier. There is also a built-in safety to lock the blade closed. When it shows red, you are ready to go.

What also makes the Trident so unique is the patent pending Groove™ in the handle, which allows the operator to cut paracord, fishing line, etcetera without having to open the blade.

Check out Digi-Grip™, this variable patterning creates a coarser grip in areas that will require it. The bayonet style clip is easily switched for right/left hand carry or removed for pouch storage.

- |                      |              |                    |
|----------------------|--------------|--------------------|
| <b>37791</b> (TF-1): | • Black TiNi | • ½ Serrated Blade |
| <b>37296</b> (TF-2): | • Stainless  | • Straight Blade   |
| <b>37797</b> (TF-5): | • Camo TiNi  | • ½ Serrated Blade |



Fusion Micron



### SOG® Fusion Micron

**3.44" Open • 1.5" Blade**

This tiny beauty is crafted from high quality stainless steel and designed to be carried on a key ring or stashed in your pocket. It's a SOG® so you know the Micron is built to last and is going to be there when you need it.

**37967 (Micron):** • Stainless • Straight Blade



Pentagon Elite

### SOG® Pentagon Elite

**8.75" Open • 4 x .135" Blade**

The Pentagon Elite knives are impeccably balanced and feature ergonomic glass and Kevlar-reinforced Zytel handles, ambidextrous slotted thumb studs, machine screw construction, a low-reflective bead-blasted blade and clip, SOG®'s Arc-Lock system, and a reversible military-style clip that enhances gripping. Spearheading the Pentagon Elite is a shark tooth tip that increases point strength.

**37369 (PE14):** • Stainless • ½ Serrated Blade



Flash Rescue

### SOG® Flash Rescue – Orange Handle

**8" Open • 3.5 x .125" Blade**

The Flash family of knives feature SOG® Assisted Technology™ (S.A.T.), which employs a powerful piston lock that is easily released with a sliding button. The Flash Rescue comes standard with glass-reinforced nylon (GRN) handle and ½ serrated sheep's foot blade in Satin finish. All Flash knives come standard with SOG®'s patent pending, reversible bayonet mounted clip that ensures the lowest, most discreet carry possible. Includes an additional safety lock that gives added security when the blade is closed.

**37876 (OFSA-6):** • Stainless • ½ Serrated Blade



Contractor I

### SOG® Contractor I

**6.25" Open • 2.625 x .1" Blade**

The Contractor series is designed specifically for tradesmen, including electricians, handymen, and for those who take pride in a job well done. Modernizing traditional patterns, this knife features: lockback design, patent pending holes/notches for stripping wire, aggressive Aluminum grips, one hand opening, and razor sharp blades.

**37927 (EL-10):** • Stainless • Straight Blade



Blink

### SOG® Blink

**5.37" Open • 2.25 x .090" Blade**

Blink combines the proven design of the lockback with lightning quick blade access. Thanks to S.A.T. (SOG® Assisted Technology™), the blade is propelled open once the operator has initiated the one-handed opening action.

**37768 (BBA-99):** • Stainless • Straight Blade



Twitch I

### SOG® Twitch I

**4.75" o.a.l. • 2 x .1" Blade**

SOG Twitch I feature a pass-through lockbar (patent pending) from which the "kick" of the blade sticks through. By pressing on the "kick", one is able to initiate the opening of the blade. S.A.T. (SOG® Assisted Technology™) then takes over to finish opening and to securely lock the blade open.

**37774 (TWI-7):** • Stainless • Straight Blade



Twitch II

### SOG® Twitch II

**6.2" Open • 2.68 x .100" Blade**

S.A.T. (SOG® Assisted Technology™) brings the standard lockback knife (which is one of the oldest known knife locks on the planet) into the 21st century. This new concept will change your idea of what folding knives can be. Once the operator has initiated the blade opening action, S.A.T. propels the stainless steel blade out and firmly locks it into place.

**37763 (TWI-8):** • Stainless • Straight Blade



Twitch XL

### SOG® Twitch XL

**7.5" Open • 3.25 x .125" Blade**

This is a high-tech statement of sophistication with all the bells and whistles that you expect from the designers at SOG®, including our SOG® Assisted Technology™. The fine construction comes together to make the XL one of the most practical and beautiful knives that we have ever handled.

**37795 (TWI-22):** • Stainless • Straight Blade

### SOG® Kilowatt

#### 7.5" Open • 3.4 x .120" Blade

Get 'charged up' with the Kilowatt, the first working theme knife designed for the electrician or anyone who might need to strip wire in a pinch. Three septate systems address wire from fine multi strand all the way up to cable. There is a stripper bar for wire sizes of 12-24, an adjustable spring-loaded UPT/wire stripper in the back, and just in case, a patent pending hole stripper that uses the main blade. Schematic grips, i voltage tower clip, insulator thumb stud, and a blade with receptacle engraving are signatures that make this a very unique liner lock knife.

37972 (EL-01): • Satin • Straight Blade



Kilowatt Cable/Wire Stripper



TOOLS



Revolver – Hunter

### SOG® Revolver – Hunter

#### 10" Open • 4.75 x .15" Blade

The Hunter Revolver is the definitive knife for the outdoorsman, hunter, archer, fisherman, and sportsman. With a gut hook, large flat bevel grinds, and a bone/wood saw, you can dress game, cut tree stands, build shelter, and still have enough left to clear that pesky redwood tree out of your way.

A glass-reinforced nylon (GRN) handle hides the stainless steel liners which ensure strength and quality. And as always, SOG edges are razor sharp.

Includes Nylon sheath.

37918 (FX-20): • Stainless • Straight/Double-Tooth Saw Blade



Fielder Mini

### SOG® Fielder Mini

#### 6.5" Open • 2.75 x .09" Blade

Introducing the beautiful new Fielder Mini. The contrast of the vertical grain wood against the high luster bolsters creates a very appealing visual tension. This is a knife that is comfortable as a daily carry or out in the wilds. Using a proven liner lock system provides reliability as well as one-hand opening of the Fielder Mini's capable blade.

37926 (FF-33): • Stainless • Straight Blade



Pentagon

### SOG® Pentagon

**9.75" o.a.l. • 5 x .125" Blade**

The Pentagon offers the instant choice between a serrated or beveled edge for cutting options. Twin thumb notches enable accurate blade orientation and downward control. The aggressively checkered, flared handles provide confident gripping as well as sensational feel and balance.

Tactical Nylon sheath.

**37390 (S14):** • Stainless • Straight/Serrated Blade



Pentagon Mini

### SOG® Pentagon Mini

**7.75" o.a.l. • 3.5 x .125" Blade**

Extremely lightweight and comfortable to maneuver, the Mini Pentagon also offers the instant choice between a straight or serrated edge for multiple cutting tasks. Twin thumb notches on the blade enable accurate blade orientation and downward control. Like its big brother, the Mini Pentagon has aggressively checkered, flared Kraton handles for confident gripping as well as sensational feel and balance.

Includes Kydex sheath.

**37395 (M14):** • Stainless • Straight/Serrated Blade



Field Pup

### SOG® Field Pup

**8.5" o.a.l. • 4 x .130" Blade**

The Field Pup is a beautiful knife with its high gloss satin finish. It's comfortable to use with its slightly yielding Kraton molded handle that form fits the full tang blade. SOG®'s trademarked finger grips are combined with aggressive thumb notches on the back of the blade, making the Field Pup a real working knife.

**37765 (FP3):** • Satin Polish • Straight Blade



Seal Team

### SOG® SEAL Team

**12.3" o.a.l. • 7 x .24" Blade**

The SEAL Team knife, formerly known as the SEAL Knife 2000, evaluation program included: tip breaking stress, blade breaking limit, sharpness, edge retention, handle twist off force, two week salt water immersion tests, gasoline and acetylene torch resistance, chopping, hammering, prying, penetration tests, cutting six different types of rope and line, plus an intense hands-on competition in the field.

**37389 (S37):** • Stainless • ½ Serrated Blade





Seal Pup Elite

### SOG® SEAL Pup Elite

**9.5" o.a.l. • 4.85 x .185" Blade**

The SEAL Elite series is a high performance edition to the existing SEAL family of products. The SEAL Elite series is serious business and carries on the tradition of supplying the world's elite military forces. Includes extended Tang for glass breaking and hammering applications.

**37789 (E37T):** • Black TiNi • ½ Serrated Blade



Seal Pup

### SOG® SEAL Pup

**9" o.a.l. • 4.75 x .160" Blade**

The SEAL Pup carries on the tradition of quality and service of the SOG® SEAL Knife. To earn this honor, the SEAL Knife surpassed one of the most extensive testing and evaluation programs ever undertaken by the US Government.

**37393 (M37):** • Stainless • ½ Serrated Blade



Seal Team Elite

### SOG® SEAL Team Elite

**8" o.a.l. • 3.5 x .125" Blade**

Our battle proven SEAL Knife series has an incredible reputation for reliability and performance on fronts throughout the world.

Features include: Matte black hardcased™ TiNi blade, longer ergonomic handle with deeper fingergrooves, racy new blade shape and longer cutting edge, spine rasp for notching, and extended tang for glass breaking and hammering.

**37976 (SE-37):** • Black TiNi • ½ Serrated Blade



Entrenching Tool

### SOG® Entrenching Tool

**18.25" o.a.l. • 7.25" c.a.l.**

A folding shovel can be an indispensable tool in today's constantly changing environment. Our all steel construction entrenching tool uses a tempered steel blade with teeth cut into it for cutting and slashing. The triangular handle is strong and fits the hand well.

**37929 (F08):** • Black TiNi

### **SOG<sup>®</sup> Warranty Information**

All SOG<sup>®</sup> products are guaranteed against defects in workmanship and materials for the life of the original purchaser. This guarantee is voided (as determined by SOG<sup>®</sup>) by misuse, abuse, improper maintenance, or alterations of the product and does not cover any normal wear that might occur. All guarantee claims should be sent directly to SOG<sup>®</sup> Specialty Knives, Inc. U.S. claims should be prepaid insured. International claims should write or call for information.

All Fusion by SOG<sup>®</sup> products are guaranteed against defects in workmanship and materials for one year from date of purchase. This guarantee is voided (as determined by SOG<sup>®</sup>) by misuse, abuse, improper maintenance, or alterations of the product and does not cover any normal wear and tear that may occur.

All guarantee claims should be directed to the factory. U.S. claims should be sent prepaid and insured. For international claims, call or write SOG<sup>®</sup>'s Warranty Department for information. SOG<sup>®</sup> reserves the right to the repair or replacement of a product at our discretion.

#### **Examples of Non-Warranty Items:**

- Broken or bent knife tips, tool components, sheaths/pouches (if sheaths are determined to fall under warranty, they are warranted separately from the knife/tool), thumbstuds, bent/broken knife clips, dull/chipped knife blades, blade/tool coatings, Kraton slabs.
- Rusting of Carbon, Stainless Steel and TiNi
- Sheaths and pouches are not covered under this warranty. Cases of surface rust, bent and broken knife tips, and coatings are also not covered under this warranty.

#### **When returning product, please do the following:**

Include a brief note inside your package stating what you are returning, the claimed defect, and how it failed. On that note, put your name, return address, daytime phone number, and your email address. Insure your package for the full retail value of the contents.

#### **Send all warranty claims to:**

SOG<sup>®</sup> Specialty Knives & Tool, Inc.  
Attn: Warranty Department  
6521 212th St. SW  
Lynnwood, WA 98036

### URASEAL SPLICE KITS



#### ES137S ★

Smaller butt and branch splice applications.



#### ES200S ★

Butt and branch splice applications.



#### ES200SV ★

Perfect for small hard-to-reach areas. The closure snaps into place over the splice. Can be used for butt, branch or through splice applications.



#### ES1150 ★

For a range of cable sizes from 8-4/0 and 250 mcm single service conductors.

Wire Type	Butt Splice Configuration			Through Splice Configuration	
	ES137S	ES200S	ES200SV	ES200SV	ES1150
	Number of Conductors (Max.)			Number of Conductors (Max.)	
18-16	Up to 10	Up to 20	Up to 14	Up to 14	—
14-12	6	12	9	9	—
10	4	8	6	6	—
8	3	6	4	4	4
6	2	2	2	2	3
4	2	2	2	2	2
3	2	2	2	2	2
2	1	2	2	2	2
1	1	2	2	2	2
1/0	—	—	—	—	2
2/0	—	—	—	—	2
3/0	—	—	—	—	2
4/0	—	—	—	—	2
250 mcm	—	—	—	—	2

★ Made in USA

TOOLS

### ABSOLUTE PROTECTION FOR ANY SPLICE IN A WET OR DAMP ENVIRONMENT

Fix any broken cable using Uruseal's Shake N' Seal splice protection system. Developed specifically for the electrical market, this new splicing system provides a permanent seal that is 100% water tight.



This proven technology has been used in similar sealing applications for over 30 years without failure!

Replaces the sheath integrity with an absolute seal around the splice or damaged cable. Add a length of wire to a run, or build a branch splice. Safe and easy to use. No need for a torch or open flame.

Easy as...



#### Features

- Submersible in water
- No mess
- Immediate burial
- Safe, no torch
- Permanent Seal
- Set-up less than 2 minutes!



### TAPE MEASURE



- Tough, impact resistant plastic case.
- Comfortable sleeve for better grip.
- Hands-free blade lock.

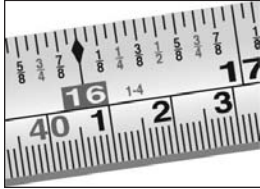

Description	Part #	Qty
Tape Measure 25' x 1"	<b>86980</b>	1

TOOLS

### QUICKIE TIE-DOWN STRAPS



- Patented, self-locking rope pulley.
- The quickest, easiest tie-down on the market.
- Comes with 8 feet of high quality rope to fasten a variety of loads.
- Carries a one year warranty on manufactured parts, so you can be assured of quality.
- 1/4" – 150 lb (Safe Working Load)
- 3/8" – 400 lb (Safe Working Load)

Description	Part #	Unit	Qty
1/4" Quickie Tie Down Strap	<b>37216</b>	1	12
3/8" Quickie Tie Down Strap	<b>37218</b>	1	12

### TARP STRAPS



- Exceptional performance even under the harshest conditions.
- Features pre-inserted "S" hooks.

Description	Part #	Qty
9" Rubber Tarp Strap	<b>37204 ★</b>	1
15" Rubber Tarp Strap	<b>37205 ★</b>	1
20" Rubber Tarp Strap	<b>37206 ★</b>	1
24" Rubber Tarp Strap	<b>37207 ★</b>	1
31" Rubber Tarp Strap	<b>37208 ★</b>	1
41" Rubber Tarp Strap	<b>37209 ★</b>	1

★ Made in USA

## YELLOW POLYPROPYLENE PULL ROPE

Rope Diameter	Length (ft)	Work Load (lbs)	Break Point (lbs)	Part #
3/16	250	72	800	<b>67800</b>
3/16	600	72	800	<b>67802</b>
3/16	1000	72	800	<b>67804</b>
3/16	1200	72	800	<b>67806</b>
3/16	3000	72	800	<b>67808</b>
3/16	3600	72	800	<b>67810</b>
1/4	250	113	1250	<b>67812</b>
1/4	600	113	1250	<b>67814</b>
1/4	1000	113	1250	<b>67816</b>
1/4	1200	113	1250	<b>67818</b>
1/4	2400	113	1250	<b>67820</b>
1/4	4000	113	1250	<b>67822</b>
1/4	5000	113	1250	<b>67824</b>
3/8	300	243	2700	<b>67826</b>
3/8	600	243	2700	<b>67828</b>
3/8	1200	243	2700	<b>67830</b>
3/8	2400	243	2700	<b>67832</b>
3/8	3600	243	2700	<b>67834</b>
1/2	300	378	4200	<b>67836</b>
1/2	600	378	4200	<b>67838</b>
1/2	1200	378	4200	<b>67840</b>
5/8	600	558	6200	<b>67842</b>
5/8	1200	558	6200	<b>67844</b>
3/4	600	756	8500	<b>67846</b>
1	600	1260	14000	<b>67848</b>



- Safety yellow
- Light weight
- Strong
- Rot Proof
- Water, oil and gas resistant
- Available in all popular sizes
- Longer lengths available
- Double braided available

TOOLS

## POLYESTER PULLING TAPE/MULE TAPE

- Durable foot markings for accurate measurements.
- Flat construction and lubricants work to minimize friction and duct cutting.
- Soft construction for easy handling.



Width	Length (ft)	Tensile (lbs)	Part #	MFG #
1/2	500	1250	<b>67680</b> ★	P1250W
1/2	1500	1250	<b>67682</b> ★	P1250W
1/2	3000	1250	<b>67684</b> ★	P1250W
5/8	500	1800	<b>67686</b> ★	P1800W
5/8	1500	1800	<b>67688</b> ★	P1800W
5/8	3000	1800	<b>67690</b> ★	P1800W
3/4	500	2500	<b>67692</b> ★	P2500W
3/4	1500	2500	<b>67694</b> ★	P2500W
3/4	3000	2500	<b>67696</b> ★	P2500W



★ Made in USA

## POLYESTER CONDUIT MEASURING TAPE



- Durable foot markings for accurate measurements.
- Low elongation polyester.

Length (ft)	Tensile (lbs)	Part #	MFG #	Unit	Case Qty
3000	140	<b>67700</b> ★	P160S	1	8

★ Made in USA

## POLYPROPYLENE BLOW TWINE



- Lightweight construction.
- Blows easily into conduit.

Description	Length (ft)	Tensile (lbs)	Part #	MFG #	Unit
Two Ply (Pail)	6500	200	<b>67699</b> ★	BL200BKT	1

★ Made in USA

## LINE PACKAGES



- 1/2" red, 3/4" yellow, 1" white.
- Line packages combine piston and string into a single package. With a portable blower you can blow or vacuum the nylon line and pull a rope through.
- Nylon Fishline features center feed for fast payout.

Nylon Fishline			
Size	Strength	Part #	No./Pkg
2150'	85# Tensile	<b>67730</b> ★	1 Spool

★ Made in USA

Size	Part #	No./Pkg
1/2 x 75'	<b>67710</b> ★	10
1/2 x 150'	<b>67712</b> ★	10
3/4 x 75'	<b>67714</b> ★	10
3/4 x 200'	<b>67716</b> ★	5
3/4 x 300'	<b>67718</b> ★	5
3/4 x 450'	<b>67720</b> ★	5
1 x 75'	<b>67722</b> ★	10
1 x 200'	<b>67724</b> ★	5
1 x 300'	<b>67726</b> ★	5
1 x 450'	<b>67728</b> ★	5

TOOLS

## FOAM CONDUIT PISTONS

Size	Part #	No./Pkg
1/2	<b>67740</b> ★	5
3/4	<b>67742</b> ★	5
1	<b>67744</b> ★	5
1 1/4	<b>67746</b> ★	2
1 1/2	<b>67748</b> ★	1
2	<b>67750</b> ★	1
2 1/2	<b>67752</b> ★	1
3	<b>67754</b> ★	1
3 1/2	<b>67756</b> ★	1
4	<b>67758</b> ★	1
5	<b>67760</b> ★	1
6	<b>67762</b> ★	1

★ Made in USA

- Power fishing pistons are used with a vacuum or blower to pull line through a conduit run.
- Fits most conduits 1/2" through 6".
- Eyes or hooks at both ends.
- Tough foam piston cleans its own path and provides an air tight seal.



## RECEPTICAL SHIM

Gravity Feed Jar		
Description	Part #	Jar Qty/ Std Pk
25 Strips of 8 Shims per Jar	<b>CPRS25J</b> ★	25/150

★ Made in USA

- Each strip has 8 foldable (tear off) segments.
- Each segment provides 1/8" spacing.
- No need to remove screw.
- Low density polyethylene; non-conductive.

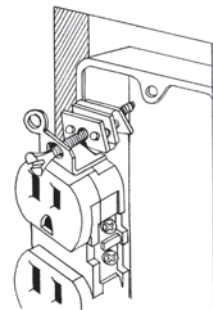

## NON-METALLIC SHEATHED CABLE CONNECTORS

- Industry leading 60lb wire pull-out vs. 25lb of several competitors.
- Long body with rounded edges = easier and safer installations.
- Capacities:  
RC50 One Cable: 14/2, 12/2, 10/2, 14/3, 12/3, 10/3  
Two cable: 14/2, 12/2, 14/3  
RC75 One Cable: 8/3 – 6/3
- CSA approved.
- VO fire rated.

### RC50 Common Uses:

- Load Centers
- Down Lights (i.e. Cans)
- Strip Lights, Exhaust Fans
- Any 1/2" K/O where non-metallic cable is allowed.

### RC75 Common Uses:

- Load Centers
- Sub Feeds
- Electric Ranges
- Electric Ovens
- A/C Units
- Any 3/4" K/O where non-metallic cable is allowed.



Description	Hang Tag Bag		5x11 Plastic Jar	
	Part #	Std Pkg	Part #	Std Pkg
1/2" Non-Metallic Sheathed Connector	<b>RC50</b>	100	<b>RC50J</b>	275
3/4" Non-Metallic Sheathed Connector	<b>RC75</b>	50	<b>RC75J</b>	165

## PLASTIC STEEL STUD BUSHINGS



- Patented one piece design means no mating of pieces and only one piece to keep track of.
- Easy and quick installation and removal.
- UL and CSA approved.
- VO fire rated.

	Hang Tag Bag	5x11 Plastic Jar		
Description	Part #	Std Pkg	Part #	Std Pkg
Round Steel Stud Bushing	<b>RSS</b>	100	<b>RSSJ</b>	200
Square Steel Stud Bushing	<b>SSS</b>	100	<b>SSSJ</b>	125

## ANTI-SHORT BUSHINGS



- Prevents damage to wire installation.
- Constructed of thermoplastic material.

Description	Fits Cable	Part #	Jar Qty/ Std Pk
Size 0 Anti-Short Bushing	14/2, 14/3, 12/2, 12/3	<b>67420J</b>	50/600
Size 1 Anti-Short Bushing	14/4, 6/1, 4/1	<b>67421J</b>	50/600
Size 2 Anti-Short Bushing	12/4, 10/2, 10/3, 2/1	<b>67422J</b>	50/300
Size 3 Anti-Short Bushing	10/4, 8/2, 8/3, 1/1	<b>67423J</b>	25/150
Size 4 Anti-Short Bushing	8/4, 6/2, 6/3, 6/4, 4/2, 4/3	<b>67424J</b>	25/150

## KNOCK-OUT BUSHINGS



- Converts raw-edged holes to smooth, neat, insulated holes.
- Locking fingers snap into holes with fingertip pressure.
- Withstands a push back force of 35 lbs.
- Insulates and mechanically protects electrical and telecommunication cables, tubing, hose, rope and utility lines.

Description	Part #	Box Qty
½" Knock Out Bushing	<b>95090</b>	100
¾" Knock Out Bushing	<b>95092</b>	100
1" Knock Out Bushing	<b>95094</b>	50
1¼" Knock Out Bushing	<b>95096</b>	25
1½" Knock Out Bushing	<b>95098</b>	10
2" Nylon Knock Out Bushing	<b>95100</b>	10
2½" Nylon Knock Out Bushing	<b>95102</b>	10



### COLOR-CODED PVC ELECTRICAL TAPE • “PHASE TAPE”

- 7mil tape features excellent insulation and anti-corrosion qualities. UL-Listed.
- An economical tape that remains flexible even in extreme temperatures. Can be applied from 40°F to 176°F.
- Cellophane wrapped in sleeves of 10.

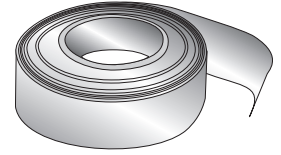

Size	Color	Part #	Unit	Sleeve Qty
¾ x 60'	Brown	<b>94361</b>	1 Roll	10
¾ x 60'	Red	<b>94362</b>	1 Roll	10
¾ x 60'	Orange	<b>94363</b>	1 Roll	10
¾ x 60'	Yellow	<b>94364</b>	1 Roll	10
¾ x 60'	Green	<b>94365</b>	1 Roll	10
¾ x 60'	Blue	<b>94366</b>	1 Roll	10
¾ x 60'	Grey	<b>94368</b>	1 Roll	10
¾ x 60'	White	<b>94369</b>	1 Roll	10

### BLACK PVC ELECTRICAL TAPE • PREMIUM & ECONOMY

- Both tapes feature UL-Listed 7 mil PVC with excellent insulation and anti-corrosion qualities.
- Premium tape offers greater adhesion and elasticity, especially in cold in weather environments.

Size	Color	Part #	Sleeve Qty
¾ x 60'	Black Economy	<b>94315</b>	10
¾ x 60'	Black Premium	<b>94317</b>	10

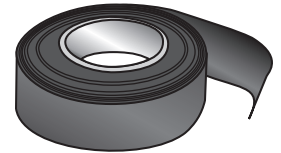

### RUBBER TAPE • BLACK

- Rubber tape has low adhesive quality, designed to be used as a surface covering with friction tape or vinyl tape.
- 30mil UL-Listed tape suitable for use up to 176°F.

Size	Color	Part #	Unit	Sleeve Qty
¾ x 22'	Black	<b>94325</b>	1 Roll	10



### FRICTION TAPE • CONTRACTOR GRADE

- Strong adhesive quality often used for wrapping low-voltage splices.

Size	Color	Part #	Unit
¾ x 60'	Black	<b>94320</b>	1 Roll

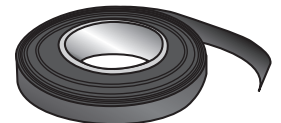

### DUCT TAPE • INDUSTRIAL GRADE • CLOTH LAMINATE

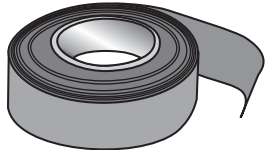

- 11 mil industrial grade tape is coated with rubber base adhesive for extra adhesion.

- Premium grade is equivalent to NASUA #357.
- Economy tape is 8 mil.

Size	Description	Part #	Unit	Pkg Qty
2" x 60 Yards	Premium	<b>94357</b>	1 Roll	24
2" x 60 Yards	Standard	<b>94396</b> ★	1 Roll	24
2" x 60 Yards	Economy	<b>94394</b> ★	1 Roll	24

★ Made in USA

### CARTON SEALING TAPE • GENERAL PURPOSE TAPE

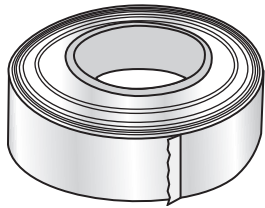

- Good all-purpose tape for packaging, mailing and for quick fix solutions.

- Will fit most standard hand-held packaging tape dispensers.

Size	Description	Part #	Unit	Pkg Qty
2" x 55 Yards	Clear	<b>94330</b> ★	1 Roll	6

★ Made in USA

### STRAPPING TAPE • GLASS FILAMENT • NON-TEARING

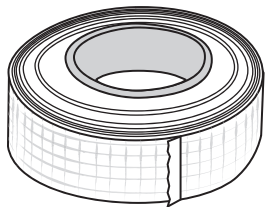

- Excellent choice for bundling lumber and pipes.
- Fits most hand-held strapping tape dispensers.
- Abrasion-resistant tape is reinforced with glass yard filaments for maximum strength.

Size	Part #	Unit	Pkg Qty
¾ x 60 Yards	<b>94340</b> ★	1 Roll	12

Tensile Strength = 100lbs/inch

★ Made in USA

### PIPE WRAP



- Protects overhead and buried pipe joints, conduit and couplings.

- Resistant to oil, water, sun and corrosive materials.
- Universal Plumbing Code approved.

Description	Part #	Unit	Std Pack
1" x 100' 10 mil UPC Approved Pipe Wrap	<b>94433</b> ★	1 Roll	12
2" x 100' 10 mil UPC Approved Pipe Wrap	<b>94434</b> ★	1 Roll	6
4" x 100' 10 mil UPC Approved Pipe Wrap	<b>94435</b> ★	1 Roll	3
2" x 100' 20 mil UPC Approved Pipe Wrap	<b>94436</b> ★	1 Roll	6

★ Made in USA

## BARRICADE & CAUTION TAPE • 4 MIL REPEATING WARNINGS

Size	Legend	Color	Part #	Unit	Std Pack
3" x 1000'	"Gas Line Below"	Yellow	<b>94607</b>	1 Roll	8
6" x 1000'	"Gas Line Below"	Yellow	<b>94614</b>	1 Roll	4
3" x 1000'	"Caution-Caution-Caution"	Yellow	<b>94625</b>	1 Roll	8
6" x 1000'	"Caution High Voltage"	Yellow	<b>94628</b>	1 Roll	8

Other messages available.



## UNDERGROUND BURIAL TAPE • 4 MIL CONTINUOUS REPEAT WARNINGS

Size	Legend	Color	Part #	Unit	Std Pack
3" x 1000'	"Buried Electrical Line"	Red	<b>94605</b>	1 Roll	8
3" x 1000'	"Buried Electrical Line"	Yellow	<b>94606</b>	1 Roll	8
6" x 1000'	"Buried Electrical Line"	Red	<b>94615</b>	1 Roll	4
6" x 1000'	"Buried Electrical Line"	Yellow	<b>94616</b>	1 Roll	4
3" x 1000'	"Buried Fiber Optic Telephone"	Orange	<b>94617</b>	1 Roll	8
6" x 1000'	"Buried Fiber Optic Telephone"	Orange	<b>94618</b>	1 Roll	4

Other messages available.



**SAFETY**

## UNDERGROUND DETECTABLE TAPE • 5 MIL FOIL BONDED POLYETHYLENE

Size	Legend	Color	Part #	Unit	Std Pack
3" x 1000'	"Buried Electrical Line"	Silver w/Red Stripes	<b>94635</b>	1 Roll	8
6" x 1000'	"Buried Electrical Line"	Silver w/Red Stripes	<b>94636</b>	1 Roll	4
3" x 1000'	"Buried Water Line Below"	Silver w/Blue Stripes	<b>94638</b>	1 Roll	8
6" x 1000'	"Buried Water Line Below"	Silver w/Blue Stripes	<b>94639</b>	1 Roll	4
3" x 1000'	"Buried Telephone Line Below"	Silver w/Orange Stripes	<b>94640</b>	1 Roll	8
6" x 1000'	"Buried Telephone Line Below"	Silver w/Orange Stripes	<b>94641</b>	1 Roll	4

Other messages available.





### INFINITY PROTECTIVE EYEWEAR

Attractive and comfortable, these glasses are appealing to the eye and face while serving as a tough optical shield of protection.

- High-grade Polycarbonate construction.
- Meets and exceeds ANSI Z87+ high-impact specifications.

- Lenses provide 99.9% protection from harmful UVA/UVB rays.
- Comfort fit rubber nosepiece.
- Nonslip rubber temple ends.
- Ultralight frame design for comfortable fit.



Part #	Crossfire® Model #	Description
19100	241	Black Frame w/Smoke Lens
19101	263	Black Frame w/Silver Mirror Lens
19102	2117	Brown Frame w/HD Brown Mirror Lens
19103	2812	Black & Orange Frame w/Gold Mirror Lens

### SNIPER PROTECTIVE EYEWEAR

Designed for tactical vision, these glasses serve as a stylish option for the sniper who seeks long lasting eye protection.

- TR-90 ultraflex, ultralight frame technology.
- Meets and exceeds ANSI Z87+ high-impact specifications.

- Lenses provide 99.9% protection from harmful UVA/UVB rays.
- Comfort fit Rubber nosepiece.
- Soft, nonslip Rubber temple ends.



Part #	Crossfire® Model #	Description
19105	9117	Brown Frame w/Brown Mirror Lens
19106	9141	Brown/Camo Frame w/Smoke Lens

### ES4 SAFETY GLASSES

Crossfire® ES4 Safety Glasses are designed for all environments and features an adjustable nose piece, ultralight frame and 100% visually correct lenses.

- Half frame



Part #	Crossfire® Model #	Description
19135	2141	Black Frame w/Smoke Lens
19136	2169	Black Frame w/HD Red Mirror Lens
19137	211125	Brown Frame w/HD Brown Mirror Lens

### ES5 SAFETY GLASSES

Crossfire® ES5 Safety Glasses are designed for outdoor sports and features a polished look with a light weight fit. The sleek framework provides substantial

coverage for a variety of environments.

- Half frame



Part #	Crossfire® Model #	Description
19125	2961	Pearl Black Frame w/Smoke Lens
19126	29117	Brown Frame w/HD Brown Mirror Lens
19127	29215	Black Frame w/Indoor/Outdoor Lens



## COBRA PROTECTIVE EYEWEAR

Protect your peepers while on patrol in Crossfire® Cobra Protective Eyewear. Exceeding high-impact standards, these glasses boast tough durability and comfort for the law professional on-the-go.

- High-grade Polycarbonate construction.

- Meets and exceeds ANSI Z87+ high-impact specifications.
- Lenses provide 99.9% protection from harmful UVA/UVB rays.
- Comfort fit rubber nosepiece.
- Soft, nonslip rubber temple ends.
- Ultralight frame design for comfortable fit.



Part #	Crossfire® Model #	Description
19110	1541	Black Frame w/Smoke Lens

## CORE PROTECTIVE EYEWEAR

Designed with the law professional in mind, these glasses are extremely durable and lightweight.

- Meets and exceeds ANSI Z87.1-2003 high impact standards.

- 99.9% protection from harmful UVA and UVB rays.
- 100% visually correct decentered lenses.
- Rubber nose pads.
- Temple grips.



Part #	Crossfire® Model #	Description
19115	18146	Woodland Brown/Camo Frame w/HD Brown Mirror Lens

## KP6 SAFETY SUNGLASSES

Crossfire® KP6 Safety Sunglasses are stylish enough to wear on or off the job.

- Polycarbonate ¾-frame



Part #	Crossfire® Model #	Description
19130	3441	Black Frame w/Smoke Lens
19131	3469	Black Frame w/Red Mirror Lens
19132	34257	Brown Frame w/Brown Mirror Lens

## RPG SAFETY SUNGLASSES

The newly redesigned full frame Crossfire® RPG Safety Glasses make the list once again as one of Crossfire's best selling styles. Fitting a wide range of users,

it is offered in various lens selections for application in diverse environments.

- Full frame



Part #	Crossfire® Model #	Description
19120	23233	Black/Red Frame w/Silver Mirror Lens

SAFETY

# Nemesis™

### Sleek, sporty style!

Nemesis safety glasses meet ANSI Z87.1+ impact standards and provide 99.9% protection from harmful UV rays.

FogGard® Plus is a permanent lens coating proven to eliminate lens fogging in 99% of workplace applications.

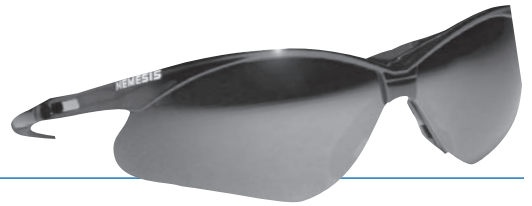

Part #	Description
19804	Black Frame w/Clear Lens
19805	Black Frame w/Clear FogGard™ Lens
19806	Black Frame w/Smoke Mirror Lens
19807	Black Frame w/Indoor/Outdoor Lens
19808	Black Frame w/Blue Mirror Lens
19809	Black Frame w/Amber Lens
19810	Blue Frame w/Light Blue Lens
19811	Camo Frame w/Bronze Lens
19812	Camo Frame w/Clear Anti-Fog Lens
19814	Camo Frame w/Amber Anti-Fog Lens

SAFETY

# Nemesis-VL™

- Frameless ultra-lightweight design – 33% lighter weight than Nemesis.
- No-brow design increases upward and peripheral vision.
- Slip-stop temples designed to prevent slipping and sliding when hot.



Part #	Description
19840	Metal Frame w/Clear Lens
19843	Metal Frame w/Indoor/Outdoor Lens
19844	Metal Frame w/Blue Mirror Lens
19880	Camo Frame w/Copper Lens

# Nemesis Rx™

- “Cheaters” style with integral adopters for vision assistance.
- Larger lens for more complete wrap around protection.
- Precise placement of inserts allows for distortion-free forward vision and increased safety when wearing.
- Enhanced nose piece design with integrated ridges to channel away sweat.
- Meets CSA.



Part #	Description
19831	Black Frame w/Clear Readers (1.5)
19832	Black Frame w/Clear Readers (2.0)



### Smith & Wesson®



- Soft rubber nose pads for superior comfort and fit.
- Sport grip temples eliminates slippage.
- Wrap-around protection.
- Lens options include anti-scratch or anti-fog coating.
- Complete with micro-fiber carry pouch that doubles as a cleaning cloth.

Part #	Description
19850	Metal Frame w/Smoke Anti-Fog Lens
19852	Blue Frame w/Blue Mirror Lens



- Steamlined, sunglass styling.
- High performance polycarbonate lens.
- Extreme lightweight design.
- Flex point temples for comfort and stability.

Part #	Description
19860	Black Frame w/Smoke Mirror Lens
19862	Black Frame w/Blue Mirror Lens

SAFETY

### OTG – OVER THE GLASSES



- Side shields provide added protection.
- Fits over most prescription glasses.
- Comfortable fit for extended wear.

Part #	Description
19870	Black Frame w/Clear FogGard™ Lens
19872	Black Frame w/Smoke Mirror FogGard™ Lens
19874	Black Frame w/Indoor/Outdoor

## DISPOSABLE DUST MASKS • GENERAL PURPOSE



### Deluxe N95 Respirator

- Meets NIOSH 42 CFR 84 standards at 95% efficiency.
- Valve reduces hot air build up.
- Collapse resistant shell last longer.



### Standard Disposable Respirator

- 100% PVC-Free. Dura-Mesh® shell resists collapsing in heat and humidity.
- Molded nose bridge seals easily without a metal noseband.
- Meets heat and flame resistant in accordance with ANSI/ISEA 110-2003 Section 7.11.1

Size	Application Environment	Part #	Pkg Qty
Economy N95 Respirator with Adjustable Metal Nose Piece	Dusty	<b>19602</b>	5
Respirator with Exhale Valve	Hot, Humid, Dusty	<b>19604</b>	10
Respirator with Molded Nose Bridge	Hot, Humid, Dusty	<b>19608</b>	50

SAFETY

## “SPARK PLUGS” HEARING PROTECTION • LOW PRESSURE FOAM



- Extra soft, low pressure foam for extra comfort.
- Noise reduction rating (NRR): 31.
- **OSHA Approval Rules:** OSHA approves hearing protection only in accordance with the noise level where it is used.

Description	Part #	Unit Pair/Bag	Box Qty
Uncorded “Spark Plugs”	<b>19610</b>	1	200
Corded “Spark Plugs”	<b>19612</b>	1	100

## SAFETY VESTS



- Conforms to MUTCD
- Bound in black cotton binding with elastic side straps and hook and loop front closure.

Description	Part #
Orange Reflective Safety Vest	<b>32065</b>
Dayglow Orange Safety Vest	<b>32066</b>
Class 2 Vest, Med-LG	<b>32067</b>
Class 2 Vest, XL-2X	<b>32068</b>



## CHARGER™ HARD HAT • OSHA COMPLIANT HARD HATS

Description	Part #	Unit
White	29430 ★	1
Yellow	29432 ★	1
Blue	29434 ★	1
Green	29436 ★	1
Red	29438 ★	1
Gray	29440 ★	1
Orange	29442 ★	1
Hi Viz Orange	29444 ★	1

★ Made in USA

- Meets ANSI Z89.1 for impact protection.
- Contoured dome for sleek profile.
- Short cap bill for greater upward vision.
- Antiglare Griptech™ bill limits glare and improves bill grip.
- Constructed for the addition of a 4-point chin strap.
- Lightweight design.



## BLOCKHEAD HARD HATS

Description	Part #	Unit
White	29410 ★	1
Yellow	29412 ★	1
Red	29418 ★	1
Hi Viz Orange	29424 ★	1

★ Made in USA

- Meets ANSI Z89.1 + 2003 standards.
- Anti-glare finish under the brim.
- Coolmax® terrycloth sweatband for comfort and easy cleaning.
- Increased thickness on the front and back brim.
- Unique smooth dome design with wide brim.



SAFETY

## HARD HAT LINERS

Description	Part #	Unit
Full Hard Hat Liner	22329	1
Hard Hat Liner w/Wrap Around Collar	22337	1

- Attaches securely to most popular hard hats.
- Constructed with durable, flame resistant Proban and Nomex.

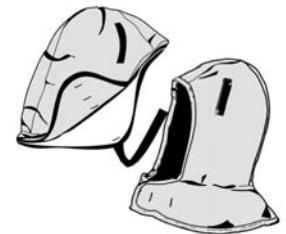

### 25 PERSON FIRST AID KIT • MEETS OSHA STANDARDS



- Meets Federal OSHA requirements.
- 25 person kit features exclusive compartmental design that holds packets firmly in place.
- Customized to meet the needs of electrical contractor.
- All the benefits of a wall mounted system in a portable box.

Description	Part #	Unit
25 Person Kit	<b>23300</b>	1



Kit Contents (147 Pieces)	
¾" x 3" Plastic Bandages	50
⅜" x 1½" Junior Plastic Bandages	30
Knuckle Fabric Bandages	2
Fingertip Fabric Bandages	2
2" x 2" Gauze Pads	10
3" x 3" Gauze Pads	4
4" x 4" Gauze Pads	2
2" x 4.5 Yard Roll Bandages	2
Triangular Sling Bandage	1
½" x 5 Yard Adhesive Tape	1
Alcohol Cleansing Pads	15
Antiseptic Cleansing Pads	9
Triple Antibiotic Ointment	2
Insect Sting Relief Pad	1
Ammonia Inhalant	1
Burn Ointment Pack	1
Sterile Eye Pad	1
Vinyl Gloves	2
6" x ¾" Finger Splint	2
#1 Safety Pins	5
Instant Cold Compress	1
Scissors	1
Tweezers	1
4 oz Eye Wash	1

### 10 PERSON FIRST AID KIT • MEETS OSHA STANDARDS



- Meets Federal OSHA requirements.
- 81 piece kit is great for service trucks.

Description	Part #	Unit
10 Person Kit	<b>23298</b>	1



Kit Contents (81 Pieces)	
¾" x 3" Plastic Bandages	25
⅜" x 1½" Junior Plastic Bandages	10
Knuckle Fabric Bandages	1
Fingertip Fabric Bandages	1
2" x 2" Gauze Pads	6
3" x 3" Gauze Pads	2
2" x 4.5 Yard Roll Bandages	1
Triangular Sling Bandage	1
½" x 5 Yard Adhesive Tape	1
Alcohol Cleansing Pads	9
Antiseptic Cleansing Pads	9
Triple Antibiotic Ointment	2
Insect Sting Relief Pad	1
Ammonia Inhalant	1
Burn Ointment Pack	1
Sterile Eye Pad	1
Vinyl Gloves	2
6" x ¾" Finger Splint	1
#1 Safety Pins	3
Instant Cold Compress	1
Scissors	1
Tweezers	1

SAFETY



### Split Leather Work Glove

Select shoulder split leather. Wing thumb. Rubberized safety cuff.

Size	Part #
L	67600
XL	67601



### Unlined Deerskin Drivers Glove

Super soft grain deerskin. Shirred elastic wrist, keystone thumb.

Size	Part #
M	67630
L	67632
XL	67634



### Split Leather Drivers Glove

Russet split leather, shirred elastic wrist, keystone thumb.

Size	Part #
M	67609
L	67611
XL	67612



### Unlined Grain Pigskin Drivers Glove

Grain pigskin with split pigskin back. Shirred elastic wrist, keystone thumb.

Size	Part #
M	67613
L	67618
XL	67622



### Grain Leather Drivers Glove

Top grade grain cowhide leather. Shirred elastic wrist, keystone thumb.

Size	Part #
M	67636
L	67638
XL	67640



### 1927® Cold Weather Grain Pigskin Glove

Grain pigskin palm, wing thumb, safety cuff. Heatkeep® thermal lining. The same lining used in ski and snowmobile gloves. Pigskin dries soft after getting wet.

Size	Part #
M	67602
L	67604
XL	67608



### Lined Brown Jersey Glove

9 oz. brown cotton jersey. Red fleece lining, straight thumb, shirred elastic back.

Size	Part #
L	67648



### Unlined Brown Jersey Glove

8 oz. brown cotton jersey. Unlined, knit wrist, straight thumb.

Size	Part #
L	67642



### Latex Coated Knit Glove

Gray knitted shell with super gripping blue latex coating.

Size	Part #
M	67650
L	67652
XL	67654



### Warm Grip Latex Work Glove

Natural rubber coating for optimal abrasion resistance. Black Mesh. Grey. Form fitted for ergonomic comfort.

Size	Part #
M	67671
L	67672



### Frostbreaker® Thermal Latex Gripping Glove

Black acrylic knit shell, knit wrist, dipped blue color latex palm and fingers.

Size	Part #
M	67663
L	67664
XL	67665



### White String Knit Glove

Medium weight polyester/cotton knit with elasticized wrist.

Size	Part #
L	67658



### Nitrile Palm Coated Glove

Navy blue nylon knit shell, gray color smooth finish nitrile coated palm and fingers.

Size	Part #
S	67509
M	67510
L	67511
XL	67512



### Fingerless Ragg Wool Glove

85% Wool/15% Nylon Ragg Wool for maximum warmth. Fingerless for dexterity on intricate jobs.

Size	Part #
L	67695



### Kevlar® Lined Glove

Kevlar® lined, cut-resistant, durable, non-slip reinforcement palm. Grey Mesh. Black.

Size	Part #
M	67624
L	67625
XL	67626



### White Canvas Glove

8 oz. white canvas. Knit wrist for snug fit.

Size	Part #
L	67661



### PVC Dipped Glove

Black PVC over cotton lining. Suggested for most oils, acids, caustics, alcohols and solvents. Use with care. 12" long.

Size	Part #
L	67662

See page 283 for our  
Glove Display offers!



### Pro-Grip Full Finger Glove

PVC Reinforced palm, thick stretch nylon between fingers. Full finger for extra protection. Black.

Size	Part #
M	67561
L	67563
XL	67565



### Pro-Grip Half Finger Glove

PVC reinforced palm, thick stretch nylon between fingers. Grey Mesh. Half fingered for extra dexterity. Black.

Size	Part #
M	67551
L	67553
XL	67555



### Pro-Grip Winter Plus Glove

100% waterproof and windproof. Triple layer insulating system. Keeps hands warm and dry. Black.

Size	Part #
M	67579
L	67581
XL	67583
XXL	67584
M	67579CAMO
L	67581CAMO
XL	67583CAMO



### Pro-Grip Mechanic's Plus Glove

Water and oil resistant synthetic suede palm. Incredible dexterity. Internal knuckle protection. Terry cloth brow wipe on thumb. Blue.

Size	Part #
M	67567
L	67569
XL	67571



### Pro-Grip Mesh General Utility Glove

Designed for warm temperatures. Breathable gray mesh. Non-slip reinforced palm, finger and thumb. Black.

Size	Part #
M	67573
L	67575
XL	67577

## ROOF JACKS (FLASHINGS)

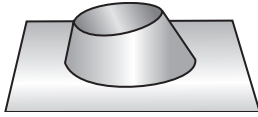

Description	Part #	Unit	Std Pack
1/2" Standard Roof Jacks	95000	1	12
3/4" Standard Roof Jacks	95002	1	12
1" Standard Roof Jacks	95004	1	12
1 1/4" Standard Roof Jacks	95006	1	24
1 1/2" Standard Roof Jacks	95008	1	24
2" Standard Roof Jacks	95010	1	24
3" Standard Roof Jacks Bath Vent	95012	1	12
4" Standard Roof Jacks Bath Vent	95014	1	12

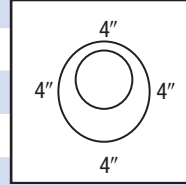

Save 10% for ordering standard pack.

## SERVICE ENTRANCE CAPS



- Clamp-on
- Aluminum
- For Rigid, IMC and EMT

Description	Part #	Std Pack
1/2" Service Entrance Cap	95120	10
3/4" Service Entrance Cap	95122	5
1" Service Entrance Cap	95124	5
1 1/4" Service Entrance Cap	95126	5
1 1/2" Service Entrance Cap	95128	5
2" Service Entrance Cap	95130	1
2 1/2" Service Entrance Cap	95132	1
3" Service Entrance Cap	95134	1
3 1/2" Service Entrance Cap	95136	1
4" Service Entrance Cap	95138	1

MISCELLANEOUS

## PRE-KUTS PLASTIC SLEEPERS



- Plastic Pre-Kuts will outlast any wood or foam sleeper.
- Lightweight, easier to haul than wood sleepers.
- No special clamps needed.
- Most economical solution for this application.
- 4 1/4" x 9" x 1 1/2"
- Clamshell.

Description	Part #	Pkg Qty
Pre-Kuts	96160 ★	10

★ Made in USA

See Minerallac pages 204-207 for One Hole Straps.

### QUICK-CAPS & QUICK SPACERS • CONDUIT INSTALLATION CLIPS

EMT			
Size	Color	Part #	Bag Qty
½" Quick Cap	Beige	<b>37604</b> ★	50
½" Quick Spacer	Beige	<b>37605</b> ★	50
¾" Quick Cap	Orange	<b>37606</b> ★	50
¾" Quick Spacer	Orange	<b>37607</b> ★	50
1" Quick Cap	Yellow	<b>37608</b> ★	50
1" Quick Spacer	Yellow	<b>37609</b> ★	50

Rigid			
Size	Color	Part #	Bag Qty
½" Quick Caps	Black	<b>37596</b> ★	50
½" Quick Spacers	Black	<b>37597</b> ★	50
¾" Quick Caps	Red	<b>37600</b> ★	50
¾" Quick Spacers	Red	<b>37601</b> ★	50
1" Quick Caps	Blue	<b>37602</b> ★	50
1" Quick Spacers	Blue	<b>37603</b> ★	50

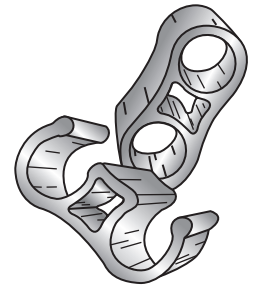

- Conduit Spacer holds pipes apart and keeps them steady for pouring concrete or fill.
- Quick Cap fits snugly over tip of pipe to keep out construction debris.
- Reusable – Will withstand the rigors of normal construction.
- Eliminates the need for duct taping conduit together.

*...a reliable solution to keep pipes in place for pouring concrete.*

★ Made in USA

Description	Part #	Box Qty
Product Function Counter Display	<b>00064</b>	1



MISCELLANEOUS

### CABLE TENSIONING TOOL & CABLE TIE KITS

- Black cable ties are UV rated.

Description	Part #
Cable Tie Tensioning Tool	<b>22298</b> ★

Kits			
Part #	Description		
<b>22290</b> ★ (400 Piece Kit)	<b>Natural</b>	4"–18lb (200 Pieces)	7"–50lb (100 Pieces) 11"–50lb (100 Pieces)
	<b>Black</b>	4"–18lb (200 Pieces)	7"–50lb (100 Pieces) 11"–50lb (100 Pieces)
<b>22292</b> ★ (400 Piece Kit)	<b>Natural</b>	4"–18lb (200 Pieces)	7"–50lb (100 Pieces) 11"–50lb (100 Pieces)
	<b>Black</b>	4"–18lb (200 Pieces)	7"–50lb (100 Pieces) 11"–50lb (100 Pieces)
<b>22294</b> ★ (401 Piece Kit)	<b>Natural</b>	4"–18lb (200 Pieces)	7"–50lb (100 Pieces) 11"–50lb (100 Pieces)
	<b>Black</b>	4"–18lb (200 Pieces)	7"–50lb (100 Pieces) 11"–50lb (100 Pieces)
<b>22296</b> ★ (401 Piece Kit)	<b>Natural</b>	4"–18lb (200 Pieces)	7"–50lb (100 Pieces) 11"–50lb (100 Pieces)
	<b>Black</b>	4"–18lb (200 Pieces)	7"–50lb (100 Pieces) 11"–50lb (100 Pieces)



★ Made in USA

### MOUNTING BASES • ADHESIVE-BACKED/PUNCH-OUT SCREW HOLE



• Four-sided design, adhesive backing and punch-through screw hole provide virtually unlimited options for attaching and holding.

• Black mounting bases are UV rated.

Length	Color	Part #	Bag Qty
¾	Natural	<b>22280</b> ★	100
¾	Black	<b>22282</b> ★	100
1	Natural	<b>22284</b> ★	100
1	Black	<b>22286</b> ★	100

### CABLE TIES

★ Made in USA



• Tensile strength exceeds industry standards to give you the holding power you need.

• Black cable ties are UV rated.

Length	Color	Tensile Strength (lbs)	Min/Max Bundle Diameter	Part #	Bag Qty
4	Natural	18	¼-1⅞	<b>22200</b> ★	100
4	Black	18	¼-1⅞	<b>22202</b> ★	100
5	Natural	40	¼-1⅞	<b>22204</b> ★	100
5	Black	40	¼-1⅞	<b>22206</b> ★	100
7	Natural	50	¼-1⅞	<b>22208</b> ★	100
7	Black	50	¼-1⅞	<b>22210</b> ★	100
8	Natural	40	¼-2⅜	<b>22212</b> ★	100
8	Black	40	¼-2⅜	<b>22214</b> ★	100
11	Natural	50	¼-3⅛	<b>22216</b> ★	100
11	Black	50	¼-3⅛	<b>22218</b> ★	100
14	Natural	50	¼-4⅞	<b>22220</b> ★	100
14	Black	50	¼-4⅞	<b>22222</b> ★	100
14	Natural	120	¾-4⅞	<b>22224</b> ★	100
14	Black	120	¾-4⅞	<b>22226</b> ★	100
36	Natural	175	¾-11	<b>22228</b> ★	50
36	Black	175	¾-11	<b>22230</b> ★	50

★ Made in USA

### MOUNTING TIES



• Screws into wood or metal for simple, secure cable bundling.

• Black mounting ties are UV rated.

Length	Color	Tensile Strength (lbs)	Min/Max Bundle Diameter	Part #	Bag Qty
7	Natural	50	¼-1¾	<b>22240</b> ★	100
7	Black	50	¼-1¾	<b>22244</b> ★	100
11	Natural	50	¼-3⅛	<b>22254</b> ★	100
11	Black	50	¼-3⅛	<b>22256</b> ★	100
14	Natural	50	¼-4	<b>22258</b> ★	100
14	Black	50	¼-4	<b>22260</b> ★	100
14	Natural	120	¾-4	<b>22262</b> ★	100
14	Black	120	¾-4	<b>22264</b> ★	100

★ Made in USA



## WALL PLATE INSULATING GASKETS • FOAM THERMAL BARRIER

- Universal design fits all standard and decorative toggle/duplex receptacles.
- Excellent thermal barrier prevents heat loss and reduces drafts through outlets and switches.
- Foam is rated #94HF1.

Description	Part #	Box Qty
Insulating Gasket	80014 ★	100

★ Made in USA

**Installation:** Insert one foam gasket in each outlet or switch box on perimeter walls.

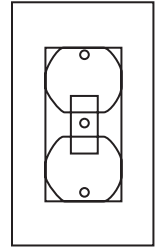

## REDUCING WASHERS • ZINC PLATED

Size	Cardboard Box	
	Part #	Qty
3/4 x 1/2	33400	100
1 x 1/2	33402	100
1 x 3/4	33404	100
1 1/4 x 1/2	33406	50
1 1/4 x 3/4	33408	50
1 1/4 x 1	33410	50
1 1/2 x 1/2	33412	50
1 1/2 x 3/4	33414	50
1 1/2 x 1	33416	50
1 1/2 x 1 1/4	33418	50
2 x 1/2	33420	25
2 x 3/4	33422	25
2 x 1	33424	25
2 x 1 1/4	33426	25
2 x 1 1/2	33428	25

Size	Cardboard Box	
	Part #	Qty
2 1/2 x 1	33430	25
2 1/2 x 1 1/4	33432	25
2 1/2 x 1 1/2	33434	25
2 1/2 x 2	33436	25
3 x 1	33438	10
3 x 1 1/4	33439	10
3 x 1 1/2	33440	10
3 x 2	33441	10
3 x 2 1/2	33443	10
3 1/2 x 1 1/2	33442	10
3 1/2 x 2	33444	10
3 1/2 x 2 1/2	33446	10
3 1/2 x 3	33448	10
4 x 2	33450	10
4 x 2 1/2	33452	10
4 x 3	33454	10
4 x 3 1/2	33456	10

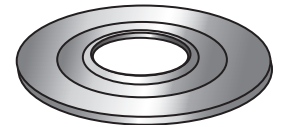

MISCELLANEOUS

## REDUCING BUSHINGS • ZINC PLATED

Size	Cardboard Box	
	Part #	Qty
1/2 x 3/8	67450	100
3/4 x 1/2	67452	100
1 x 1/2	67454	50
1 x 3/4	67456	50
1 1/4 x 1/2	67458	25
1 1/4 x 3/4	67460	25
1 1/4 x 1	67462	25
1 1/2 x 1/2	67464	25
1 1/2 x 3/4	67466	25
1 1/2 x 1	67468	25
1 1/2 x 1 1/4	67470	25

Size	Cardboard Box	
	Part #	Qty
2 x 1/2	67472	10
2 x 3/4	67474	10
2 x 1	67476	10
2 x 1 1/4	67478	10
2 x 1 1/2	67480	10
3 x 2	67484	1
3 x 2 1/2	67486	1
3 1/2 x 2	67488	1
3 1/2 x 2 1/2	67490	1
3 1/2 x 3	67492	1
4 x 2	67494	1
4 x 2 1/2	67496	1
4 x 3	67498	1
4 x 3 1/2	67499	1

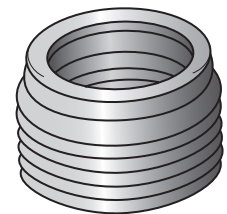

### CEILING COVER PLATE • ADJUSTABLE

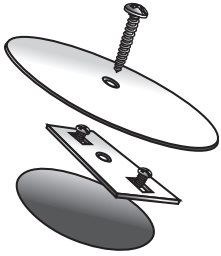

- Includes canopy, adjustable strap and machine screws.
- White metal plate adjusts to fit 3" and 4" outlet boxes.
- Useful for temporary and permanent applications.

Description	Part #	Std Pkg
5¼" White Canopy	<b>90010</b>	1/25

### SNAP-IN KNOCK-OUT SEALS • ZINC-PLATED

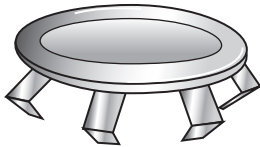

- Snap-in design for quick and easy installation.

Size	Part #	Box Qty
½	<b>90020</b>	100
¾	<b>90024</b>	100
1	<b>90028</b>	100

Size	Part #	Box Qty
1¼	<b>90032</b>	50
1½	<b>90036</b>	50
2	<b>90040</b>	25

### 3-PIECE KNOCK-OUT SEALS • ZINC-PLATED/GALVANIZED

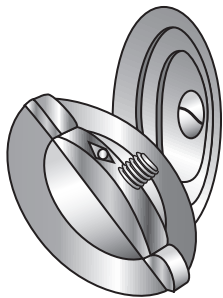

- Size is stamped on seal.

Size	Part #	Box Qty
½	<b>90050*</b>	100
¾	<b>90052*</b>	50
1	<b>90054*</b>	25
1¼	<b>90056*</b>	25
1½	<b>90058*</b>	10
2	<b>90060*</b>	10
2½	<b>90062*</b>	10

Size	Part #	Box Qty
3	<b>90064*</b>	10
3½	<b>90066</b>	10
4	<b>90068</b>	10
5	<b>90072</b>	10
6	<b>90074</b>	10

\*Comes assembled.

### NON-METALLIC KNOCK-OUT SEALS



- Easy Snap in installation – No Conductivity possible.
- Tight tolerances = snug fit in different panels/boxes.
- Fits all metallic and non-metallic material from ½" to ⅛".
- Easy installation in tight space areas.
- UL and CSA approved.
- VO fire rated.

Description	Hang Tag Bag	
	Part #	Std Pkg
½" Knock Out Non-Metallic	<b>K050</b>	50
¾" Knock Out Non-Metallic	<b>K075</b>	50
1" Knock Out Non-Metallic	<b>K0100</b>	25
1¼" Knock Out Non-Metallic	<b>K0125</b>	25
1½" Knock Out Non-Metallic	<b>K0150</b>	25
2" Knock Out Non-Metallic	<b>K0200</b>	25
Assortment Knock Out Non-Metallic	<b>KOSORT</b>	1

## WIRE & CABLE MARKER BOOKS

Cully Wire and Cable Marker Books are manufactured with high quality vinyl cloth, but are finished with an economical flat stitch for users who don't require removable pages. The book system is convenient and fits into your pocket for travel to the job.

They are mounted on 90# super release lay flat liner. The slick surface protects the adhesive until used. This assures full bonding power when applied to a wire.

Each book contains 450 wire markers and 450 matching terminal strips. Wire and cable markers are printed on impregnated cloth, the proven general purpose material for maintenance, construction and product identification.

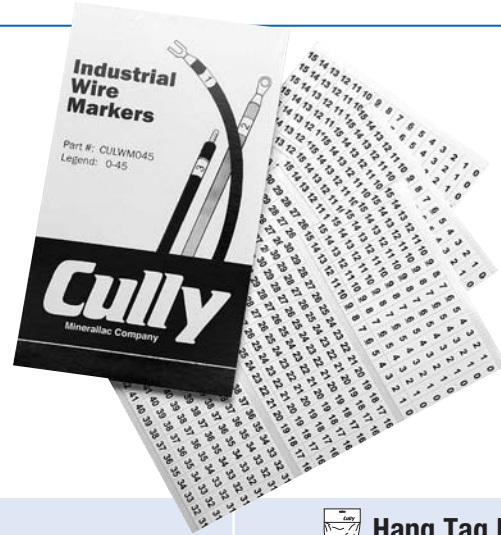

		Hang Tag Bag
Markers	Legend	Part # Qty
Wire & Cable	0 (45 each) 1-45 (10 each)	<b>CULWM045</b> ★ 1
Wire & Cable	0-9 (45 each)	<b>CULWM09</b> ★ 1
Wire & Cable	0-9 (45 each) L1, L2, L3, T1, T2, T3 (15 each)	<b>CULWM09LT</b> ★ 1
Wire & Cable	1, 2, 3 (150 each)	<b>CULWM123</b> ★ 1
Wire & Cable	1-30 (15 each)	<b>CULWM130</b> ★ 1
Wire & Cable	1-45 (10 each)	<b>CULWM145</b> ★ 1
Wire & Cable	1-90 (5 each)	<b>CULWM190</b> ★ 1
Wire & Cable	-, /, +, A-Z (2 each) 0-15 (6 each) 16-90 (4 each)	<b>CULWM190AZ</b> ★ 1
Wire & Cable	46-90 (10 each)	<b>CULWM4690</b> ★ 1
Wire & Cable	A, B, C (150 each)	<b>CULWMABC</b> ★ 1
Wire & Cable	- (7 each) + (8 each) A-Z (15 each) BLANK (21 each)	<b>CULWMAZ</b> ★ 1
Wire & Cable	-, /, +, 0-15, A-Z (10 each)	<b>CULWMAZ015</b> ★ 1
Wire & Cable	1, 2, 3, A, B, C (45 each) L1, L2, L3, T1, T2, T3 (30 each)	<b>CULWMINST</b> ★ 1
Wire & Cable	L1, L2, L3 (150 each)	<b>CULWML1</b> ★ 1
Wire & Cable	T1, T2, T3 (150 each)	<b>CULWMT1</b> ★ 1

★ Made in USA

Continued on next page.

MISCELLANEOUS

### WIRE & CABLE MARKER BOOKS (CONT.)

MISCELLANEOUS

		 Hang Tag Bag
Markers	Legend	Part #      Qty
Wire & Cable	10 NEMA Colors (45 each)	<b>CULWMNEMA</b> ★      1
Wire & Cable	Air Cond 1, Air Cond 2, Compactor, Dishwasher, Disposal, Driveway Lights, Dryer, Entertainment Center, Entry Lights, Freezer, Heating 1, Heating 2, Main, Outside Lights, Pool, Pool Heater, Range, Refrigerator, Security System, Shed, Sump Pump, Vent System, Washer, Water Heater 1, Water Heater 2, Water Pump, Whirlpool, Whirlpool Heater (5 each) Attic, Basement, Bath 1, Bath 2, Bedroom 1, Bedroom 2, Bedroom 3, Bedroom 4, Blank, Den, Dining Room, Family Room, Garage, Living Room, Master Bath, Patio, Rec Room, Smoke Detector, Sunroom, Utility Room (10 each) Kitchen, Master Bedroom (15 each) GFCI (20 each) Lights, Outlets (30 each)	<b>CULWMRC</b> ★      1
Wire & Cable	BLANK, NEUT, SPARE (21 each) GND, NEG, POS (33 each) -, +, AC, DC (45 each)	<b>CULWMVOLT</b> ★      1
Burglar/Security	1-30 (3 each) 1-45 (1 each) AC AC/AC AC (6 each) Annunciator, BA/BA, Feed/Feed, Fire/Fire, Ground, Phone Feed, Phone Return, Return/Return, Siren/Bell, Smoke Detector, Temperir Tamper, Thermostat (9 each) +Circuit+, -Circuit- (12 each) GB/GB, Keypads, PIR/PIR (15 each) AC Transformer (27 each) Blank (45 each) Zone/Zone (60 each)	<b>CULWMBA</b> ★      1
Fire/Security	1-15, 16-30 (3 each) 1-45 (1 each) AC AC/AC AC (6 each) Annunciator, Siren/Bell, Tamper (9 each) +Circuit+, -Circuit- (12 each) GB/GB, Keypads, PIR/PIR (15 each) Duct Detector, Heat Detector, Horn/Horn, Horn/Strobe, Smoke Detector, Strobe/Strobe (18 each) BLANK (45 each) Zone/Zone (60 each)	<b>CULWMFA</b> ★      1

★ Made in USA



**Minerallac**<sup>®</sup>  
*Traditional*

**Black Claw**<sup>™</sup>

**IMPACT**<sup>®</sup>  
*STAPLES*

**REDMORE**<sup>®</sup>

PICTORIAL INDEX

## LOAD RATING

Minerallac fasteners are designed with two load limits:

**Static Load Limit** is a rated stationary load limit. The listed static load limit has a safety factor of three.

**Ultimate Static Load Limit** is the rated stationary load limit which, if exceeded, may cause failure of the fastener.

Load limits are for loads applied VERTICALLY except as may be diagrammed otherwise. The load capacity of a fastener having more than one component is equal to the load capacity of the lowest rated component.

## MATERIALS

### Steel

We specify commercial quality (CQ) hot rolled pickled and oil (HRPO) or cold rolled (CR) steel for our parts where a specific material specification is not needed.

### Spring Steel

We specify a high carbon, cold rolled, annealed, spring steel for all Black Claw™ products.

### Stainless Steel

We specify 304 stainless steel for all our stocked products. However, other grades are available but minimum quantities may apply.

### Aluminum

We specify 3003-H14 on all aluminum products unless otherwise specified.

### Brass

We specify a 70/30 brass C260 1/4 hard material for all our stock products. Formerly named as Everdur® in past catalogs.

## COATINGS

### Pre-Galvanized Zinc

This coating of zinc is applied directly at the mills by rolling the material through molten zinc. Parts fabricated from this material have exposed edges where the material has been cut; but the zinc near the uncoated metal becomes a sacrificial anode to protect the bare areas for a short period of time. These parts are recommended for indoor use in dry areas.

### Zinc Plated or Electro-Galvanized

We have our parts plated after fabrication to commercial quality standards, and recommend them for indoor, relatively dry environments. Zinc plating is the process by which a coating of zinc is deposited on the steel by electrolysis from a bath of zinc salts. The zinc coating thickness for commercial quality is approximately 0.00015–0.00020 inches.

### Hot Dipped Galvanized

We submerge our parts after fabrication into a molten bath of zinc thus coating all the edges of the parts. Hot Dipped Galvanized to ASTM A123 specifications. Parts are recommended for indoor/outdoor use and mildly corrosive environments.

### Zinc Phosphate and Oil

We have most of our high carbon spring steel parts (Black Claw™) coated with this process after fabrication and heat-treating. The process applies a base of crystalline zinc phosphate of 1000 milligrams a square foot and then a synthetic organic corrosion inhibitor with a particular affinity for zinc compounds. These parts are recommended for indoor, non-corrosive environments.

### Copper Plated

We specify a commercial grade finish on all stock copper plated parts.

## WARRANTY

Minerallac warrants all products sold to be free and clear of all liens and encumbrances and to be free from defects in material and workmanship. In the event that any product fails to conform to such warranty, Minerallac's liability is limited solely to replacing such product without charge.

The warranties set forth above are exclusive and are in lieu of all other warranties whether statutory, expressed, or implied including warranties of merchantability and fitness for a

particular purpose, and warranties arising from course of dealing or usage of trade. The above provides remedy of replacement will be the sole and exclusive remedy of any purchaser of a product for any failure by Minerallac to comply with the warranty provision, whether claims by purchaser are based on contract or in tort including negligence, and in no event shall Minerallac be liable for loss of profits, indirect, special, consequential and other similar damages, and any economic loss resulting from any such failures.

See inside back cover for Terms and Conditions of Sale, return policy and freight allowance.

**CONDUIT/CABLE/WIRE**



**Conduit Hangers**  
pages 202–203



**One-Hole Straps • Jiffy Clip®**  
pages 204–207

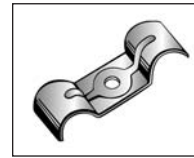

**One-Hole Duplex • Jiffy Clip®**  
page 208

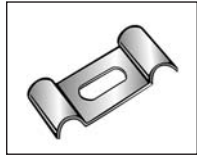

**Slotted Duplex • Jiffy Clip®**  
page 208



**Conduit Strap • Two-Hole Metal**  
pages 209–210

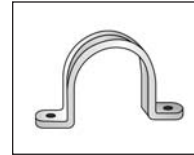

**Multi-Use Two-Hole Plastic Straps**  
page 210



**Multi-Purpose Closed Clip**  
page 210



**Service Entrance Straps • One-Hole**  
page 211



**Service Entrance Straps • Two-Hole**  
page 212

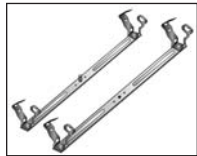

**Conduit & Box Support Fasteners**  
page 213

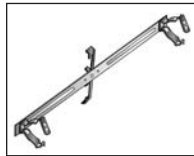

**Conduit & Box Support Assembly**  
page 214



**Universal Pipe Clamps**  
page 215



**Ground Wire Clip**  
page 215

**NAIL STRAPS**

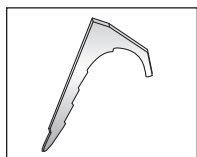

**Nail Straps**  
page 216

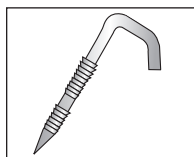

**Round Nail Straps**  
page 216

**BEAMS**



**Beam Clamps • Universal**  
page 217



**Beam Clamps • Malleable**  
page 217



**Beam Clamp Assemblies**  
page 218



**Flange/T-Bar Clip**  
page 218



**Beam Mount Conduit & Box Support Assembly**  
page 219

**METAL STUD & DRYWALL**

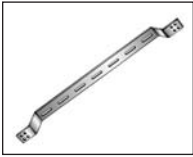

**Box Mounting Bracket**  
page 220

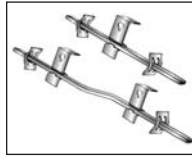

**Box to Bar Fastener**  
page 220

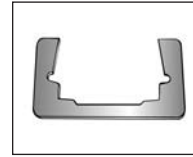

**Outlet Retainer**  
page 221



**Box Mounting Bracket**  
page 221

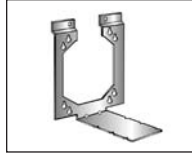

**Box Stabilizer Support**  
page 222



**Box Supports • Screwless Design**  
page 222

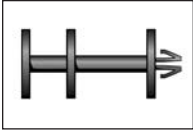

**Plastic Far Side Box Support**  
page 223

**ACOUSTICAL**

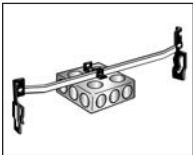

**Box to T-Bar Fastener**  
page 223



**Lighting Support Assembly**  
page 223



**T-Bar Hanger**  
page 224



**T-Bar Scissor Clips**  
page 224



**T-Bar Drop Wire Clip**  
page 224

**VOICE/DATA & LOW VOLTAGE**



**Cable Support • J Hooks**  
page 225



**Cable Support • Bridle Rings**  
pages 226–227



**Universal Metal Stud Grommet**  
page 227



**Cable Protection • Nail Plates**  
page 228

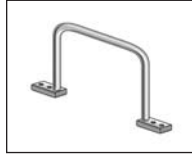

**Cable Support • D-Rings**  
page 229



**Low Voltage Mounting Bracket**  
page 229

**HARDWARE/ACCESSORIES**

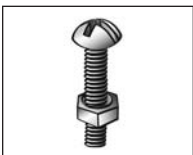

**Stove Bolt with Nut**  
page 230



**Wing Nut Washer**  
page 230



**Perforated Strapping**  
page 231



**Stud Clip Adapter**  
page 231

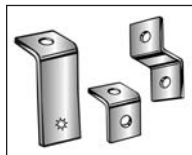

**Brackets**  
page 232

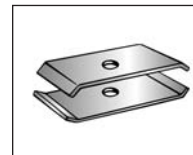

**Bar Joist Washers**  
page 232



### CONDUIT CABLE



**Conduit Clip**  
page 234

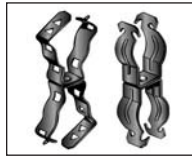

**Conduit to Conduit Trapeze Assembly**  
page 235

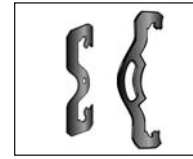

**Cable Clip**  
page 236



**Conduit Clip**  
page 236



**Multi-Function Clip**  
page 237

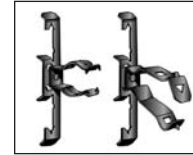

**Multi-Function Clip Assemblies**  
page 237



**Flexible Conduit/Cable Clip**  
page 238

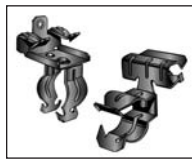

**Flange Mount Conduit Clip Assembly**  
pages 239–240

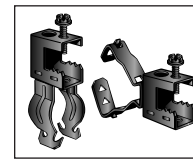

**Beam Clamp to Conduit Hanger Assemblies**  
page 245

### HANGERS

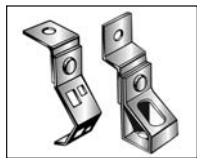

**Rod/Wire • Bracket Support**  
page 241



**Rod/Wire Beam Assemblies**  
page 242

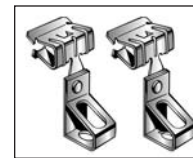

**Threaded Rod to Beam Assemblies**  
page 242



**Strap Hangers**  
page 243

### BEAM/PURLIN



**Beam Clamps**  
page 244



**Flange Beam Clamp**  
page 246

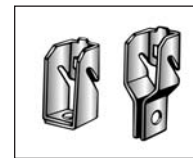

**Z Purlin Hanger**  
page 246

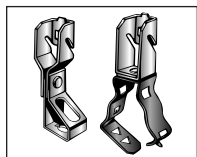

**Z Purlin Hanger Assemblies**  
pages 247–248



**Z Purlin Flange Hanger**  
page 248



**Flange Hanger**  
page 249

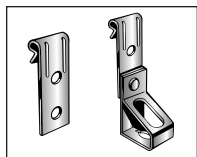

**Rod to Flange Hanger**  
page 249

### METAL STUD

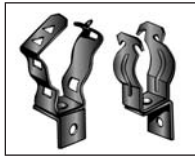

**Conduit/Cable Support**  
*page 250*

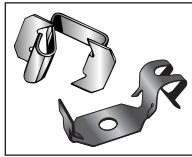

**Flexible Conduit/Cable Fastener**  
*page 250*

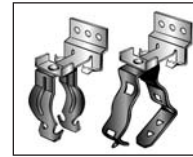

**Conduit to Stud Support**  
*page 251*

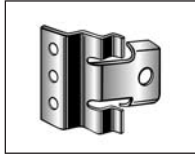

**Box To Stud Fastener**  
*page 251*

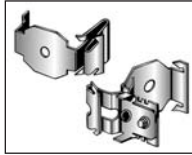

**Box To Stud Support**  
*page 252*

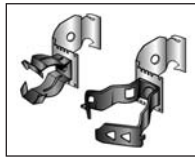

**Conduit to Stud Fastener**  
*page 253*

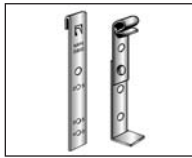

**Far Side Box Support**  
*page 253*

### ACOUSTICAL

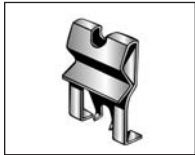

**Lighting • Troffer Fastener**  
*page 254*



**Twist on T-Bar Hanger**  
*page 254*



**T-Bar Fasteners**  
*pages 255–256*

### VOICE/DATA & LOW VOLTAGE

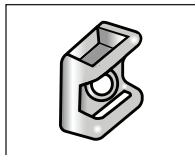

**Plastic Cable Tie Fastener**  
*page 257*

### HARDWARE/ACCESSORIES

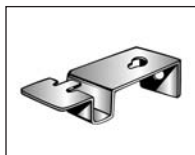

**Box To Bar Fastener**  
*page 258*

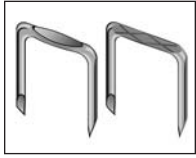

**Rod Hangers**  
*page 258*

**NON-INSULATED METAL STAPLES**

**Cable Staples**  
*page 263*

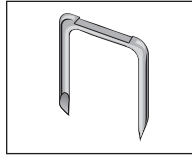

**Service Entrance Staples**  
*page 263*

**INSULATED METAL STAPLES**

**Plastic Insulator Cable Staples**  
*page 264*

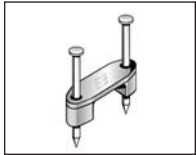

**PVC Dipped Cable Staples**  
*page 264*

**INSULATED PLASTIC STAPLES**

**Plastic Cable Staples**  
*page 265*

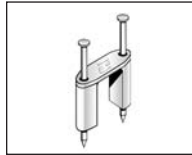

**Stacking Cable Staples**  
*page 265*



**Service Entrance Staples • Style SER**  
*page 266*

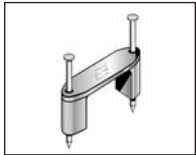

**Service Entrance Staples • Style SEU**  
*page 266*

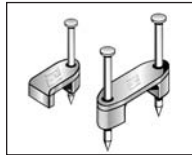

**Bell & Thermostat Staples**  
*page 266*



**Non-Metallic Sheathed Cable Staples**  
*page 266*

### DIAMOND POINT STAPLES

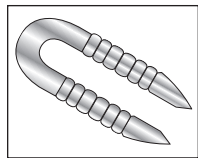

**Square Wire Barbed Staples**  
page 269

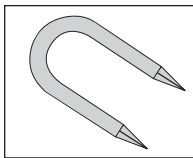

**Bright Wire Diamond Point Staples**  
pages 270–271

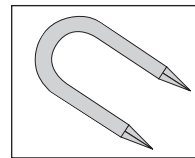

**Electro-Zinc Diamond Point Staples**  
page 271

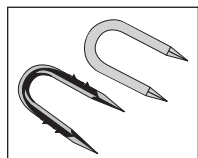

**Galvanized Diamond Point Staples**  
page 272

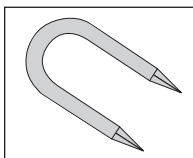

**Copperclad Diamond Point Staples**  
page 272

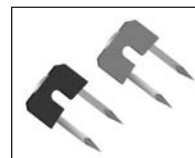

**Drive Stop® Diamond Point Staples**  
page 273

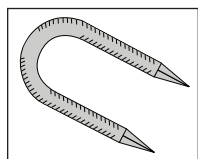

**Serrated Electro-Zinc Diamond Point Staples**  
page 273

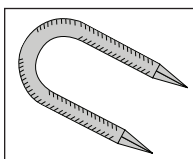

**Serrated Galvanized Diamond Point Staples**  
page 273

### CUT POINT STAPLES



**Pre-Galvanized Cut Point Staples**  
page 274



**Galvanized Cut Point Staples**  
page 275



**Copperclad Cut Point Staples**  
page 275

### NAILS



**Galvanized Roofing Nails**  
page 276



**Galvanized & Copperclad Common Nails**  
pages 276–277



**Galvanized Marking Nails**  
page 277

# Minerallac<sup>®</sup>

## Traditional

### Quality That Saves You Time

For over a hundred years, Minerallac has provided the electrical contractor with time-saving and innovative fasteners. Our "Traditional" line has expanded from the conduit hanger and one-hole "Min-E"® strap, invented and patented by Minerallac, to well over a thousand different sizes, styles and finishes of electrical fasteners from which to choose. We're sure to have the fastener, style, finish and quality you require. That's the Minerallac Advantage!

**202-215 Conduit/Cable/Wire**

**216 Nail Straps**

**217-219 Beams**

**220-223 Metal Stud & Drywall**

**223-224 Acoustical**

**225-230 Voice/Data & Low Voltage**

**231-232 Hardware/Accessories**



CONDUIT HANGERS

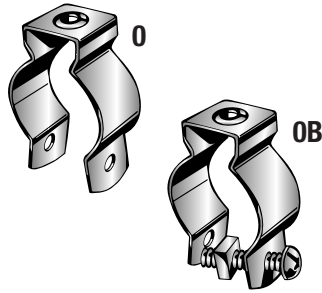
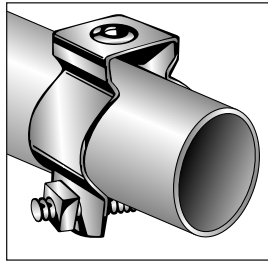

- Our standard conduit hangers come zinc-plated or made from 304 stainless steel.
- Available with or without bolt and nut attached.
- The original conduit hanger available for 1/2" through 5" conduit.

Available made from aluminum, brass or steel that has been hot dip galvanized or copper-plated. Call customer service for pricing and minimum order quantities.

See page 74 or 230 to order bolts and nuts separately.

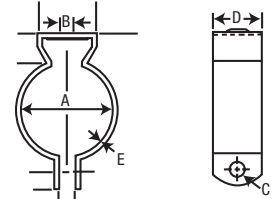

Fits Rigid/IMC	Fits EMT	Nom. Pipe O.D. A	B	C	D	E	W/O Bolt Attached Part #	With Bolt Attached Part #	Std Pkg
Zinc Plated									
3/8-1/2	1/2	0.675-0.840	1/4	1/4	.750	.050	0 ★	0B*	100
3/4	3/4	0.922-1.050	1/4	1/4	.875	.050	1 ★	1B*	100
1	1	1.163-1.315	1/4	1/4	.875	.050	2 ★	2B*	100
—	1 1/4	1.510	1/4	1/4	.875	.050	2 1/2 ★	2 1/2 B*	100
1 1/4	1 1/2	1.660-1.740	1/4	1/4	.875	.050	3 ★	3B*	100
1 1/2	—	1.883-1.900	5/16	1/4	1.000	.060	4 ★	4B*	100
2	2	2.197-2.375	5/16	1/4	1.250	.060	5 ★	5B*	50
2 1/2	2 1/2	2.857-2.875	5/16	1/4	1.250	.060	6 ★	6B*	50
3	3	3.476-3.500	5/16	5/16	1.250	.060	7 ★	7B*	25
3 1/2	3 1/2	3.971-4.000	5/16	5/16	1.250	.060	8 ★	8B*	25
4	4	4.466-4.500	1/2	1/2	1.750	.080	9 ★	9B*	10
5	—	5.563	1/2	1/2	1.750	.080	10 ★	10B*	10

\* Made in USA per Federal Trade Commission 1998

Continued on next page.

★ Made in USA

CONDUIT HANGERS (CONT.)

Fits Rigid/IMC	Fits EMT	Nom. Pipe O.D. A	B	C	D	E	W/O Bolt Attached Part #	With Bolt Attached Part #	Std Pkg
<b>Stainless Steel (Type 304)</b>									
3/8-1/2	1/2	0.675-0.840	1/4	1/4	.750	.050	<b>0S</b> ★ ♡	<b>0SB*</b> ♡	100
3/4	3/4	0.922-1.050	1/4	1/4	.875	.050	<b>1S</b> ★ ♡	<b>1SB*</b> ♡	100
1	1	1.163-1.315	1/4	1/4	.875	.050	<b>2S</b> ★ ♡	<b>2SB*</b> ♡	100
—	1 1/4	1.510	1/4	1/4	.875	.050	<b>2 1/2S</b> ★ ♡	<b>2 1/2SB*</b> ♡	100
1 1/4	1 1/2	1.660-1.740	1/4	1/4	.875	.050	<b>3S</b> ★ ♡	<b>3SB*</b> ♡	100
1 1/2	—	1.883-1.900	5/16	1/4	1.000	.060	<b>4S</b> ★ ♡	<b>4SB*</b> ♡	100
2	2	2.197-2.375	5/16	1/4	1.250	.060	<b>5S</b> ★ ♡	<b>5SB*</b> ♡	50
2 1/2	2 1/2	2.857-2.875	5/16	1/4	1.250	.060	<b>6S</b> ★ ♡	<b>6SB*</b> ♡	50
3	3	3.476-3.500	5/16	5/16	1.250	.060	<b>7S</b> ★ ♡	<b>7SB*</b> ♡	25
3 1/2	3 1/2	3.971-4.000	5/16	5/16	1.250	.060	<b>8S</b> ★ ♡	<b>8SB*</b> ♡	25
4	4	4.466-4.500	1/2	1/2	1.750	.080	<b>9S</b> ★ ♡	<b>9SB*</b> ♡	10

\* Made in USA per Federal Trade Commission 1998

★ Made in USA

♡ Harsh Environment Product

- Modeled after Minerallac's Standard Conduit Hangers, the K Series incorporates value and ease of use.
- Parts come with bolts only. Keyhole design eliminates need for nut.
- Made from pre-galvanized steel.

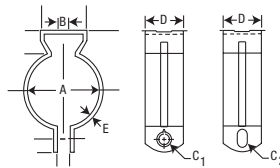

**Our Most Economical Conduit Hanger - NO NUT NEEDED!**

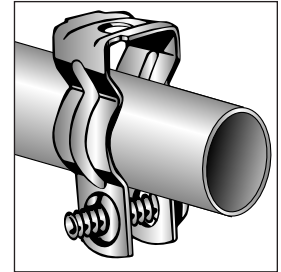

Fits Rigid/IMC	Fits EMT	Thread Imp					Part #	Std Pkg
		A	B	C <sub>1</sub>	C <sub>2</sub>	D		
<b>Pre-Galvanized</b>								
3/8-1/2	1/2	0.675-0.840	1/4	1/4-20	1/4 X 3/8	.625	.040	<b>K0B</b> 100
3/4	3/4	0.922-1.050	1/4	1/4-20	1/4 X 3/8	.750	.040	<b>K1B</b> 100
1	1	1.163-1.315	1/4	1/4-20	1/4 X 3/8	.750	.040	<b>K2B</b> 100

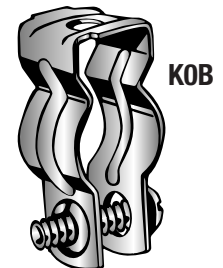

**MINERALLAC TRADITIONAL**

**ONE-HOLE STRAP • JIFFY CLIP®**

Minerallac has the widest variety of one-hole straps in the industry. If you can't find it at Minerallac, it probably doesn't exist.

Minerallac manufactures five grades of one-hole straps to fit any budget, any application. And many of our one-hole straps are available in other materials, and finishes—stainless steel, brass, copper-plated steel or hot dip galvanized steel.

From our most economical K-series one-hole straps to our best quality heavy-duty one-hole straps, you can't find a wider selection or better value anywhere.

**THE ORIGINAL JIFFY CLIP®!**

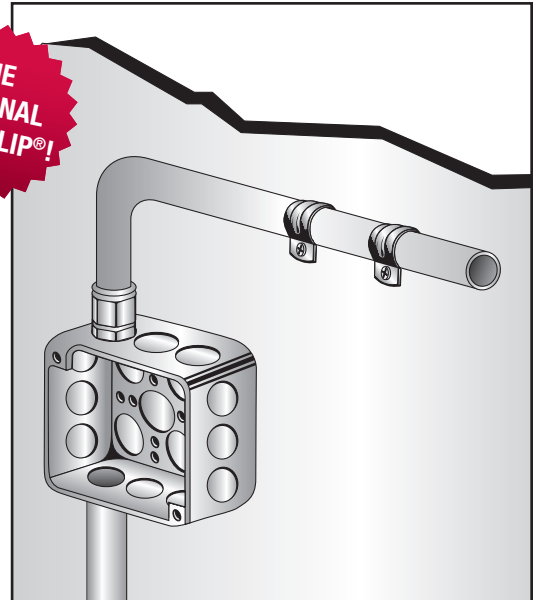

**One-Hole Jiffy Clips in Five Grades**

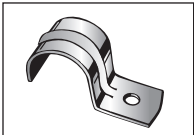

**K-Series**  
*Most Economical*

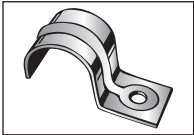

**"Standard" Series**  
*The "original" Jiffy Clip®*

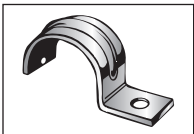

**"Min-E" Series**  
*Most Value*



**"Medium" Series**  
*Most Popular*



**"Heavy Duty" Series**  
*Strongest*

MINERALLAC TRADITIONAL

**K-Series**

- Precision made one-hole pipe straps with snap-on feature.
- Pre-galvanized steel.



**Our most economical Jiffy Clip®!**

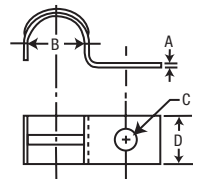

Fits EMT	Nom. Pipe O.D.				Part #	Std Pkg
	A	B	C	D		
Pre-Galvanized						
1/2	.050	0.706	1/4	0.625	<b>K30</b> ★	100
3/4	.050	0.922	1/4	0.625	<b>K45</b> ★	100
1	.050	1.163	1/4	0.875	<b>K55</b> ★	100

★ Made in USA



**ONE-HOLE STRAP • JIFFY CLIP®**

**STANDARD Series**

- These one-hole pipe straps are ideal for hanging tubing, pipe, conduit and BX cable.
- Pre-galvanized steel, except for items 135, 165, 160, and 170 which are zinc plated.
- Parts also available in copper plated or made from brass. Call customer service for pricing and minimum order quantities.

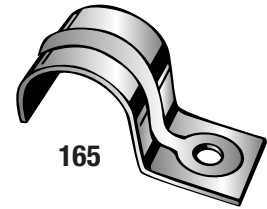
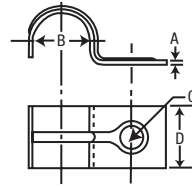

Fits Tubing O.D.	Fits Rigid	Fits EMT	Marking On Clip	A	Nom. O.D. B	Bolt C	D	No. Ribs	Part #	Std Pkg
Pre-Galvanized										
1/8	—	—	—	.035	0.125	3/16	.500	1	<b>102</b> ★	100
3/16	—	—	—	.035	0.1875	3/16	.500	1	<b>103</b> ★	100
1/4	—	—	—	.035	0.250	3/16	.500	1	<b>105</b> ★	100
5/16	—	—	—	.035	0.3125	3/16	.500	1	<b>110</b> ★	100
3/8	—	—	115	.045	0.375	3/16	.625	1	<b>115</b> ★	100
—	1/8	—	120	.045	0.405	3/16	.625	1	<b>120</b> ★	100
—	BX: 14-2, 14-3, 12-2	—	121	.045	0.475	3/16	.625	1	<b>121</b> ★	100
1/2	1/4 & BX: 12-3, 10-2, 10-3	—	125	.045	0.540	3/16	.625	1	<b>125</b> ★	100
—	3/8	1/2	130	.050	0.675–0.706	1/4	.750	1	<b>130</b> ★	100
3/4	—	—	750	.050	0.750	1/4	.750	1	<b>135*</b> ★	100
—	1/2	—	140	.050	0.840	1/4	.875	1	<b>140</b> ★	100
—	—	3/4	145	.050	0.922	1/4	.875	1	<b>145</b> ★	100
1	3/4	—	150	.050	1.000–1.050	1/4	.875	1	<b>150</b> ★	100
—	—	1	155	.050	1.163	1/4	.875	1	<b>155</b> ★	100
—	1	—	1"	.060	1.315	1/4	1.000	2	<b>160*</b> ★	100
1 1/2	—	1 1/4	1 1/4"	.060	1.500–1.510	1/4	1.000	2	<b>165*</b> ★	100
—	1 1/4	1 1/2	1 1/4"	.060	1.660–1.740	5/16	1.250	2	<b>170*</b> ★	100

\*Zinc plated

★ Made in USA

**ONE-HOLE STRAP • JIFFY CLIP®**

**MIN-E® Series**

- MinE® clips have an inverted rib providing more strength at the bend of the clip. Snap-on feature leaves both hands free to work.
- Pre-galvanized steel, except for items MINE55, MINE40, and MINE50, which are zinc plated.

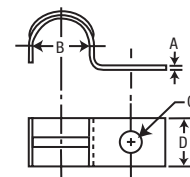

Fits EMT	A	Nom. Pipe O.D. B	Bolt C	D	Part #	Std Pkg
Pre-Galvanized						
1/2	.074	0.706	1/4	.625	<b>MINE30</b> ★	100
3/4	.074	0.922	1/4	.625	<b>MINE45</b> ★	100
1	.090	1.163	1/4	.750	<b>MINE55*</b> ★	100

\*Zinc plated  
★ Made in USA

Fits Rigid	Flexible Conduit	A	Nom. Pipe O.D. B	Bolt C	D	Part #	Std Pkg
Pre-Galvanized							
—	3/8	.074	0.560	1/4	.625	<b>MINE28</b> ★	100
1/2	1/2	.090	0.840	1/4	.750	<b>MINE40*</b> ★	100
3/4	3/4	.090	1.050	1/4	.750	<b>MINE50*</b> ★	100

\*Zinc plated  
★ Made in USA

**MEDIUM Series**

- Our best-selling precision made one-hole conduit and pipe straps.
- Clips have an inverted rib providing more strength at the bend of the clip and holding the clip on the conduit, leaving both hands free to work.
- Both zinc plated steel and stainless steel medium Jiffy Clips are available.
- Also available hot-dip galvanized steel. Call customer service for pricing and minimum order quantities.

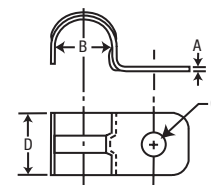
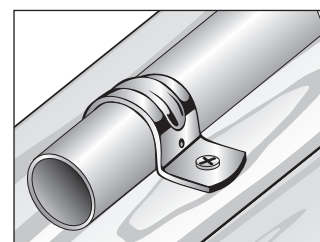

Fits EMT	Fits Rigid & IMC	A	Nom. Pipe O.D. B	Bolt C	D	Part #	Std Pkg
Zinc Plated							
1/2	—	.080	0.706	1/4	.875	<b>MED30</b> ★	100
—	1/2	.080	0.840	1/4	.875	<b>MED40</b> ★	100
3/4	—	.080	0.922	1/4	.875	<b>MED45</b> ★	100
—	3/4	.080	1.050	1/4	.875	<b>MED50</b> ★	100
1	—	.080	1.163	1/4	.875	<b>MED55</b> ★	100
—	1	.080	1.315	1/4	.875	<b>MED60</b> ★	100
1 1/4	—	.090	1.510	5/16	1.000	<b>MED65</b> ★	100
—	1 1/4	.090	1.660	5/16	1.000	<b>MED70</b> ★	100
1 1/2	—	.090	1.740	5/16	1.000	<b>MED75</b> ★	50
—	1 1/2	.120	1.900	3/8	1.000	<b>MED80</b> ★	50
2	—	.090	2.197	3/8	1.250	<b>MED85</b> ★	50
—	2	.120	2.375	3/8	1.250	<b>MED90</b> ★	50

★ Made in USA

Fits EMT	Fits Rigid & IMC	A	Nom. Pipe O.D. B	Bolt C	D	Part #	Std Pkg
Stainless Steel (Type 304)							
1/2	—	.080	0.706	1/4	.875	<b>MED30SS</b> ★	100
—	1/2	.080	0.840	1/4	.875	<b>MED40SS</b> ★	100
3/4	—	.080	0.922	1/4	.875	<b>MED45SS</b> ★	100
—	3/4	.080	1.050	1/4	.875	<b>MED50SS</b> ★	100
1	—	.080	1.163	1/4	.875	<b>MED55SS</b> ★	100
—	1	.080	1.315	1/4	.875	<b>MED60SS</b> ★	100
—	1 1/4	.090	1.660	5/16	1.000	<b>MED70SS</b> ★	100
—	1 1/2	.120	1.900	3/8	1.000	<b>MED80SS</b> ★	50
—	2	.120	2.375	3/8	1.250	<b>MED90SS</b> ★	50

★ Made in USA    ⚡ Harsh Environment Product

MINERALLAC TRADITIONAL

**ONE-HOLE STRAP • JIFFY CLIP®**

**HEAVY DUTY Series**

- With the same original inverted rib and “Snap-On” features as the medium Jiffy Clip®, this is our strongest, heavy-duty one-hole strap series.
- Zinc plated steel.

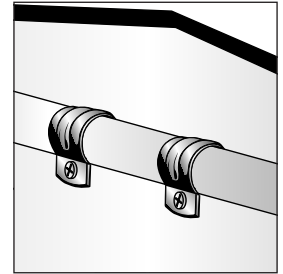
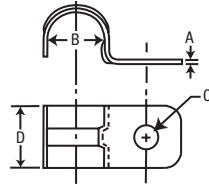

Fits Rigid & IMC	Fits EMT	A	Nom. Pipe O.D. B	Bolt C	D	Part #	Std Pkg
<b>Zinc Plated</b>							
—	½	.120	0.706	¼	.875	<b>H30</b> ★	100
½	—	.120	0.840	¼	.875	<b>H40</b> ★	100
—	¾	.120	0.922	¼	.875	<b>H45</b> ★	100
¾	—	.120	1.050	¼	.875	<b>H50</b> ★	100
—	1	.120	1.163	¼	.875	<b>H55</b> ★	100
1	—	.120	1.315	¼	.875	<b>H60</b> ★	100
—	1¼	.120	1.510	⅝	1.000	<b>H65</b> ★	100
1¼	—	.120	1.660	⅝	1.000	<b>H70</b> ★	100
—	1½	.120	1.740	⅝	1.000	<b>H75</b> ★	50
1½	—	.120	1.900	¾	1.250	<b>H80</b> ★	50
—	2	.120	2.197	¾	1.250	<b>H85</b> ★	25
2	—	.187	2.375	¾	1.250	<b>H90</b> ★	25
2½	2½	.187	2.875	⅝	1.250	<b>H92</b> ★	25
3	3	.187	3.500	⅝	1.250	<b>H94</b> ★	10
3½	3½	.250	4.000	⅝	1.250	<b>H95</b> ★	10
4	4	.250	4.500	⅝	1.250	<b>H96</b> ★	10
5	—	.250	5.563	⅝	1.500	<b>H97</b> ★	10
6	—	.250	6.625	⅝	1.500	<b>H98</b> ★	10

★ Made in USA

- Slotted Jiffy Clips® are a one-hole pipe strap with slotted mounting hole. This enables the installer to final position the clips after the run is completed.
- Copper plated steel. Parts provide compatibility with copper.
- Also available in brass. Call customer service for pricing and minimum order quantities.

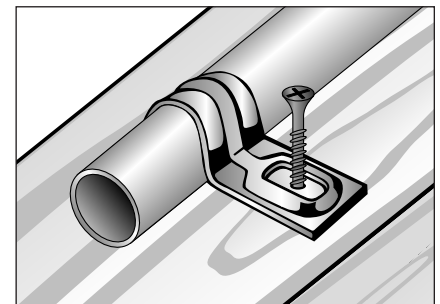

Copper Tubing O.D.	Part #	Std Pkg
<b>Copper Plated</b>		
¼	<b>105SC</b> ★	100
⅜	<b>115SC</b> ★	100

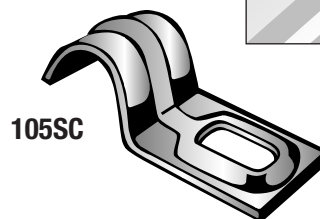

★ Made in USA

**MINERALLAC TRADITIONAL**

**ONE-HOLE DUPLEX • JIFFY CLIP®**

- For positioning double lines, these one-hole pipe clamps are ideal for cable, tube, BX or combinations thereof.
- Pre-galvanized steel.
- Also available in brass or copper plated steel. Call customer service for pricing and minimum order quantities.

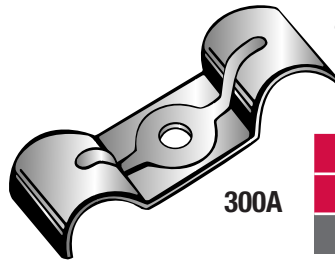
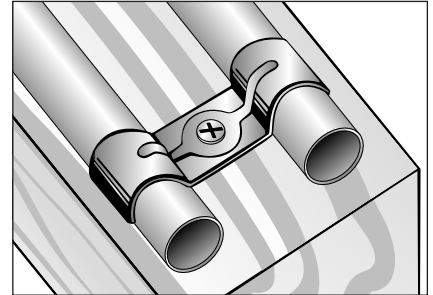
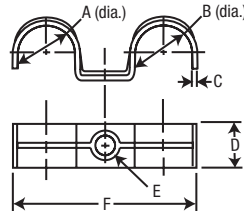

300A

Cable or Tubing		C	D	Bolt E	F	Part #	Std Pkg
A	B						
Pre-Galvanized							
.125	.125	.035	.500	3/16	.990	<b>300A</b> ★	100
.250	.250	.035	.500	3/16	1.260	<b>300</b> ★	100
.375	.375	.035	.500	3/16	1.570	<b>301</b> ★	100
.500	.500	.035	.500	3/16	1.800	<b>305</b> ★	100

★ Made in USA

**MINERALLAC TRADITIONAL**

**SLOTTED DUPLEX • JIFFY CLIP®**

- For positioning double lines.
- These copper plated steel parts provide compatibility with copper.
- Other sizes are also available. Call customer service for pricing and minimum order quantities.

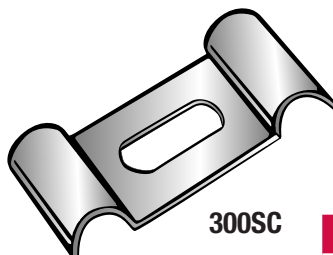
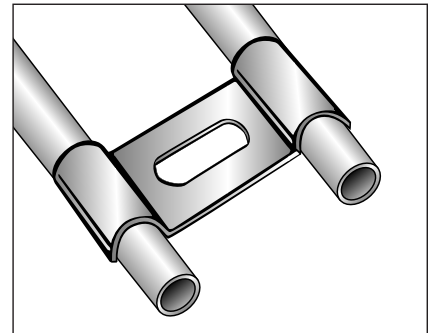
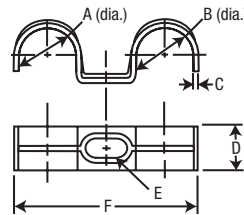

300SC

Cable or Tubing		C	D	E	F	Part #	Std Pkg
A	B						
Copper Plated							
.250	.250	.035	.500	.370	1.375	<b>300SC</b> ★	100
.375	.375	.035	.500	.380	1.510	<b>301SC</b> ★	100

★ Made in USA

**CONDUIT STRAP • TWO-HOLE METAL**

- Two-hole metal straps are designed for use on loads too heavy to be supported by one-hole Jiffy Clips.
- Pre-galvanized steel, except for 280, 290, 292 and 294 which are zinc plated.
- Available in zinc plated steel or made from stainless steel for corrosive environments.
- Also available in brass or hot-dipped galvanized steel. Call customer service for pricing and minimum order quantities.
- For information on Plastic Two-Hole Straps, available in nine sizes, turn to page 210.

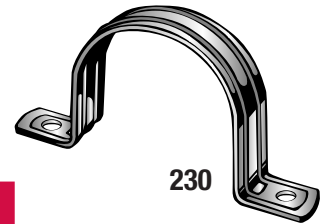
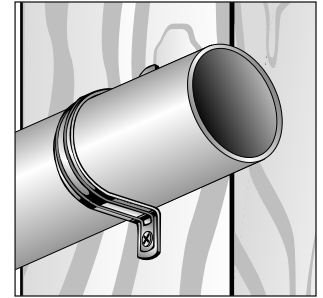
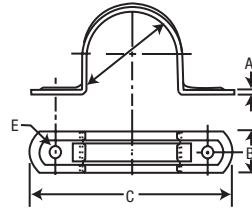

Fits EMT	Fits Rigid & IMC	A	B	C	Bolt E	Part #	Std Pkg
<b>Pre-Galvanized</b>							
—	¼	.035	.625	1.765	⅛	<b>225</b> ★	100
—	⅜	.035	.750	2.515	⅜	<b>228</b> ★	100
½	—	.035	.750	2.558	⅜	<b>230</b> ★	100
—	½	.035	.750	2.565	⅜	<b>240</b> ★	100
¾	—	.035	.750	2.765	⅜	<b>245</b> ★	100
—	¾	.035	.750	2.795	⅜	<b>250</b> ★	100
1	—	.035	.750	3.205	⅜	<b>255</b> ★	100
—	1	.035	.750	3.140	⅜	<b>260</b> ★	100
1¼	—	.050	.875	3.875	¼	<b>265</b> ★	100
—	1¼	.050	.875	4.375	¼	<b>270</b> ★	100
1½	—	.050	1.000	4.300	¼	<b>275</b> ★	100
—	1½	.060	1.000	4.585	¼	<b>280*</b> ★	100
2	—	.050	1.000	5.000	¼	<b>285</b> ★	100
—	2	.060	1.250	5.030	⅝	<b>290*</b> ★	50
2½	2½	.060	1.250	6.125	⅜	<b>292*</b> ★	50
3	3	.090	1.250	7.438	⅜	<b>294*</b> ★	25
<b>Stainless Steel (Type 304)</b>							
½	—	.035	.750	2.558	⅜	<b>230SS</b> ★	100
—	½	.035	.750	2.565	⅜	<b>240SS</b> ★	100
¾	—	.035	.750	2.765	⅜	<b>245SS</b> ★	100
—	¾	.035	.750	2.795	⅜	<b>250SS</b> ★	100

\*Zinc plated

★ Made in USA

🛡️ Harsh Environment Product

**MINERALLAC TRADITIONAL**

**CONDUIT STRAP • TWO-HOLE METAL**

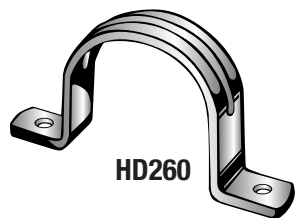

HD260

- Heavy-Duty Two-Hole Straps are designed for heavy loads.
- Zinc plated steel.
- Also available in hot-dipped galvanized steel. Call customer service for pricing and minimum order quantities.

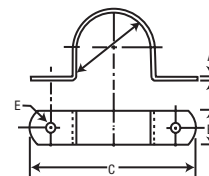

Fits Rigid & IMC	Fits EMT	A	B	C	Bolt E	Part #	Std Pkg
Zinc Plated							
1	—	.090	.750	3.092	3/16	HD260 ★	100
1 1/4	—	.080	.875	4.400	1/4	HD270 ★	100
1 1/2	—	.090	1.000	4.590	1/4	HD280 ★	50
2	—	.090	1.250	5.100	5/16	HD290 ★	25
2 1/2	2 1/2	.090	1.250	6.188	3/8	HD292 ★	25
3	3	.120	1.250	7.125	3/8	HD294 ★	10
3 1/2	3 1/2	.187	1.250	8.750	5/8	HD295 ★	10
4	4	.187	1.250	9.063	5/8	HD296 ★	10
5	—	.250	1.250	10.680	5/8	HD297 ★	10
6	—	.250	1.250	12.140	5/8	HD298 ★	10

★ Made in USA

**MULTI-USE TWO-HOLE PLASTIC STRAPS**

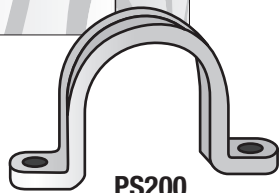
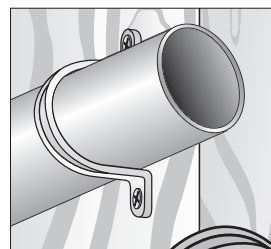

PS200

- Designed for strength.
- Easy to install. Plastic straps fit snugly over PVC or rigid conduit.
- Made from high quality UV stabilized and fire resistant material.

Trade Size	Color	Part #	Std Pkg
1/2	Gray	PS50 ★	50
3/4	Gray	PS75 ★	50
1	Gray	PS100 ★	25
1 1/4	Gray	PS125 ★	25
1 1/2	Gray	PS150 ★	25
2	Gray	PS200 ★	25
2 1/2	Gray	PS250 ★	25
3	Gray	PS300 ★	10
4	Gray	PS400 ★	10

★ Made in USA    ⚡ Harsh Environment Product

**MULTI-PURPOSE CLOSED CLIP**

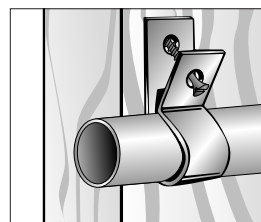

- Supports tubing pipe in sizes 1/4" O.D.
- Pre-galvanized steel.

Tubing O.D.	Part #	Std Pkg
Pre-Galvanized		
1/4	1105 ★	100

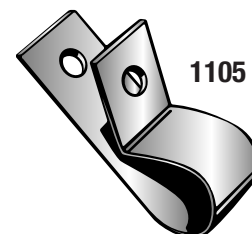

1105

★ Made in USA

MINERALLAC TRADITIONAL

**SERVICE ENTRANCE STRAPS • ONE-HOLE**

- Secures type SEU service entrance cables.
- Available in zinc plated steel or made from aluminum. MED2 and MED3 are made from pre-galvanized steel.

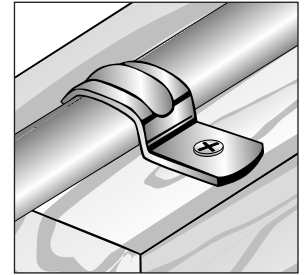
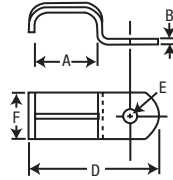

Cable Size	Inside Dia. A	B	D	Bolt E	F	Part #	Std Pkg
<b>Zinc Plated</b>							
NM (Romex)	.460	.045	1.080	3/16	.625	<b>MED2*</b> ★	100
UF	.550	.045	1.190	3/16	.625	<b>MED3*</b> ★	100
—	1.050	.074	2.056	1/4	.625	<b>MED5</b> ★	100
6, 4	.835	.080	2.148	1/4	.875	<b>MED7</b> ★	100
—	.970	.080	2.125	1/4	.875	<b>MED9</b> ★	100
2	1.090	.080	2.275	1/4	.875	<b>MED12</b> ★	100
1/0 & 2/0	1.275	.080	2.665	1/4	.875	<b>MED13</b> ★	100
—	1.465	.120	2.880	1/4	.875	<b>MED14</b> ★	100
—	1.675	.120	3.355	1/4	1.000	<b>MED16</b> ★	100
—	1.209	.120	2.500	1/4	.875	<b>H12</b> ★	100
4/0	1.570	.120	3.060	1/4	1.000	<b>H16</b> ★	100
<b>Aluminum</b>							
2	1.090	.080	2.275	1/4	.875	<b>MED12A</b> ★ ♡	100
1/0 & 2/0	1.275	.080	2.665	1/4	.875	<b>MED13A</b> ★ ♡	100
4/0	1.570	.120	3.355	1/4	1.000	<b>H16A</b> ★ ♡	100



\*Pre-galvanized

★ Made in USA

♡ Harsh Environment Product

- Secures type SER service entrance cables.
- Pre-galvanized steel, except 160 which is zinc plated.

SER & BX Fits Rigid or BX	Part #	Std Pkg
<b>Pre-Galvanized</b>		
BX: 14-2, 14-3, 12-2	<b>121</b> ★	100
BX: 12-3, 10-2, 10-3, SER 8	<b>125</b> ★	100
6, 4	<b>130</b> ★	100
2	<b>140</b> ★	100
1, 1/0	<b>145</b> ★	100
2/0	<b>150</b> ★	100
3/0	<b>155</b> ★	100
4/0	<b>160*</b> ★	100

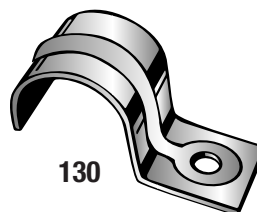
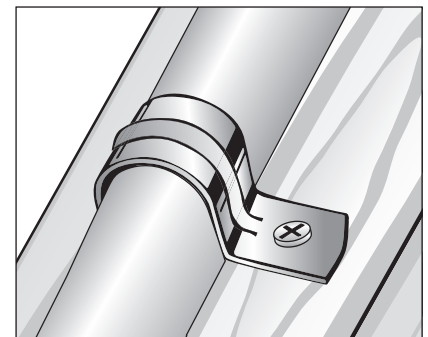

\*Zinc plated

★ Made in USA

**SERVICE ENTRANCE STRAPS • TWO-HOLE**

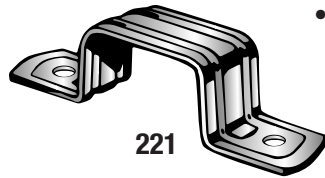

221

- Secures type SEU service entrance cables.
- Pre-galvanized steel, except 212 which is zinc plated.

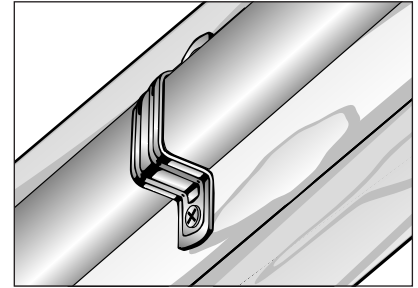
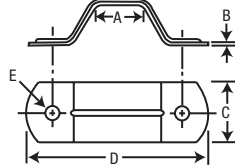

For SEU	A	B	C	D	Bolt E	Part #	Std Pkg
Pre-Galvanized							
Inside Width 0.425"	.425	.035	.750	2.070	1/8	<b>221</b> ★	100
Inside Width 0.635"	.635	.050	.750	2.895	3/16	<b>212*</b> ★	100
2	.875	.035	.750	2.690	3/16	<b>223</b> ★	100
1, 1/0, 2/0	1.100	.035	.750	3.018	3/16	<b>2203</b> ★	100
3/0, 4/0	1.340	.035	.750	2.990	3/16	<b>2403</b> ★	100

\*Zinc plated ★ Made in USA

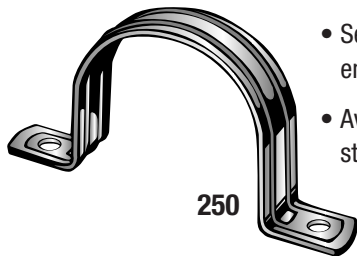

250

- Secures type SER and BX service entrance cables.
- Available made from pre-galvanized steel or stainless steel.

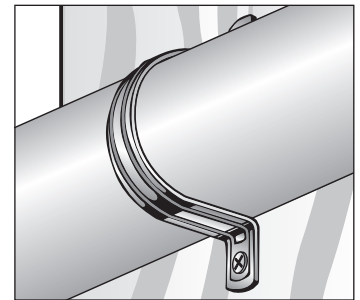
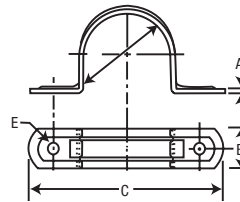

For SER & BX	A	B	C	Bolt E	Part #	Std Pkg
Pre-Galvanized						
BX, SER8	.035	.625	1.765	1/8	<b>225</b> ★	100
6	.035	.750	2.515	3/16	<b>228</b> ★	100
4	.035	.750	2.558	3/16	<b>230</b> ★	100
2	.035	.750	2.565	3/16	<b>240</b> ★	100
1, 1/0	.035	.750	2.765	3/16	<b>245</b> ★	100
2/0	.035	.750	2.795	3/16	<b>250</b> ★	100
3/0	.035	.750	3.205	3/16	<b>255</b> ★	100
4/0	.035	.750	3.140	3/16	<b>260</b> ★	100
Stainless Steel (Type 304)						
4	.035	.750	2.558	3/16	<b>230SS</b> ★ ♡	100
2	.035	.750	2.565	3/16	<b>240SS</b> ★ ♡	100
1, 1/0	.035	.750	2.765	3/16	<b>245SS</b> ★ ♡	100
2/0	.035	.750	2.795	3/16	<b>250SS</b> ★ ♡	100

★ Made in USA ♡ Harsh Environment Product

MINERALLAC TRADITIONAL



## CONDUIT & BOX SUPPORT FASTENERS

- Secures conduit and electrical boxes to most structures.
- Provides conduit support on both sides of electrical box.
- With hole for screw or threaded rod mount or with ¼"-20 x ⅝" stud.
- Made from pre-galvanized steel with Black Claw™ spring steel fasteners riveted to part.
- This part with beam clamp attachment found on page 214.

Mount 4" Square Boxes For Use With	Part #	Std Pkg
⅜" Conduit	<b>CBS18KC38</b> ★	25
½", ¾" Conduit	<b>CBS18KC1234</b> ★	25
1" Conduit	<b>CBS18KC1</b> ★	25

★ Made in USA

Stud Mount 4" Square Boxes For Use With	Part #	Std Pkg
⅜" Conduit	<b>CBS18KC38ST</b>	25
½", ¾" Conduit	<b>CBS18KC1234ST</b>	25
1" Conduit	<b>CBS18KC1ST</b>	25

- Secures conduit and electrical boxes to most structures.
- Provides conduit support on both sides of electrical box.
- With hole for screw or threaded rod mount or with ¼"-20 x ⅝" stud.
- Made from pre-galvanized steel with Black Claw™ spring steel fasteners riveted to part.
- This part with beam clamp attachment found on page 214.

Mount 4" Square Boxes For Use With	Part #	Std Pkg
½" EMT	<b>CBS18HIC50</b> ★	25
¾" EMT or ½" Rigid	<b>CBS18HIC75</b> ★	25
1" EMT or ¾" Rigid	<b>CBS18HIC100</b> ★	25

★ Made in USA

Stud Mount 4" Square Boxes For Use With	Part #	Std Pkg
½" EMT	<b>CBS18HIC50ST</b>	25
¾" EMT or ½" Rigid	<b>CBS18HIC75ST</b>	25
1" EMT or ¾" Rigid	<b>CBS18HIC100ST</b>	25

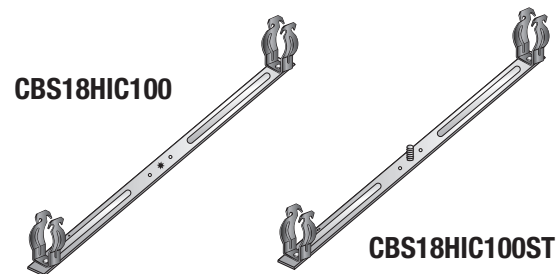
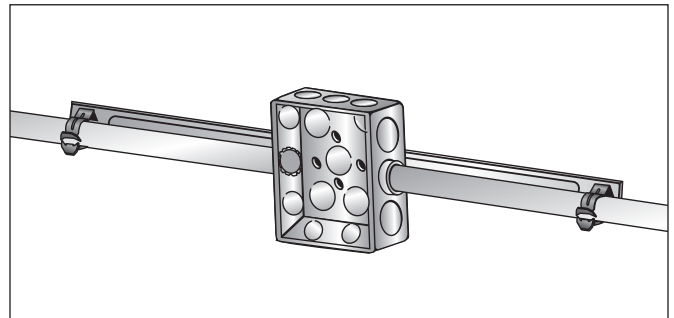
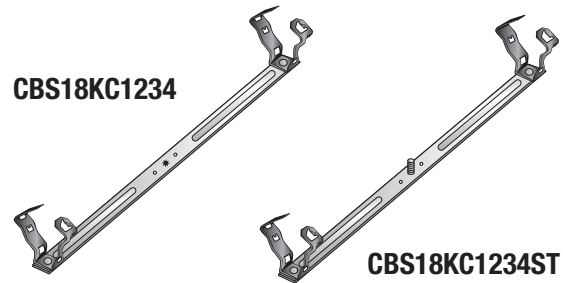
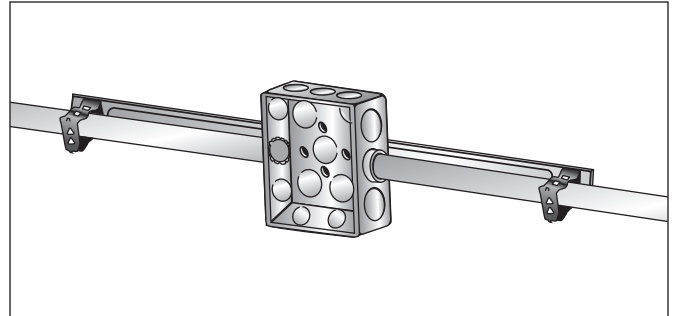

CONDUIT & BOX SUPPORT ASSEMBLY

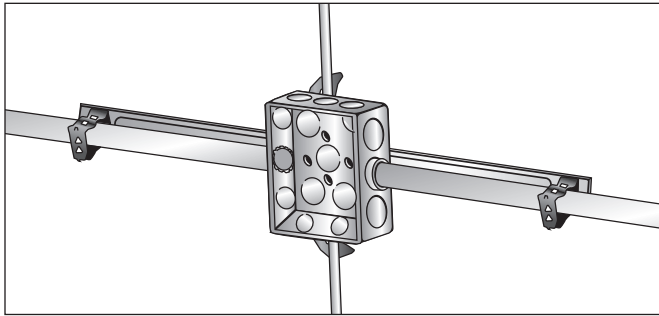

- Provides conduit support on both sides of electrical box.
- Attaches to #12 wire thru 3/8" rod.
- Made from pre-galvanized steel with Black Claw™ spring steel fasteners riveted to part.
- This part with beam clamp attachment, instead of multi-function clip shown below, found on page 219.

Mount 4" Square Boxes For Use With	Part #	Std Pkg
3/8" Conduit	<b>CBS18KC38APS</b> ★	25
1/2", 3/4" Conduit	<b>CBS18KC1234APS</b> ★	25
1" Conduit	<b>CBS18KC1APS</b> ★	25

★ Made in USA

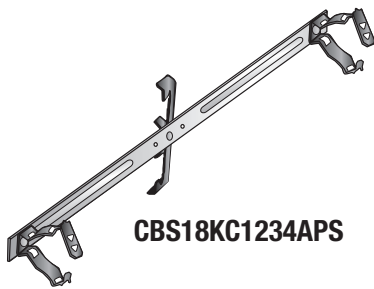

**CBS18KC1234APS**

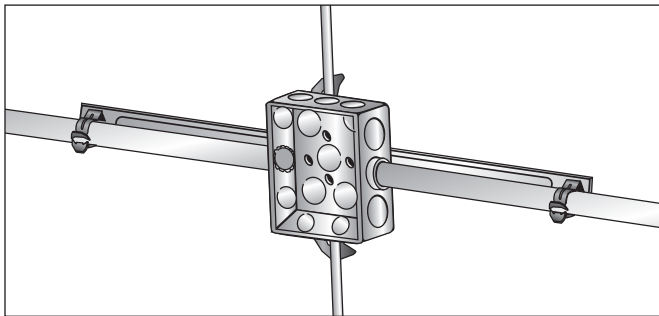

- Provides conduit support on both sides of electrical box.
- Attaches to #12 wire thru 3/8" rod.
- Made from pre-galvanized steel with Black Claw™ spring steel fasteners riveted to part.
- This part with beam clamp attachment, instead of multi-function clip shown below, found on page 219.

Mount 4" Square Boxes For Use With	Part #	Std Pkg
1/2" EMT	<b>CBS18HIC50APS</b> ★	25
3/4" EMT or 1/2" Rigid	<b>CBS18HIC75APS</b> ★	25
1" EMT or 3/4" Rigid	<b>CBS18HIC100APS</b> ★	25

★ Made in USA

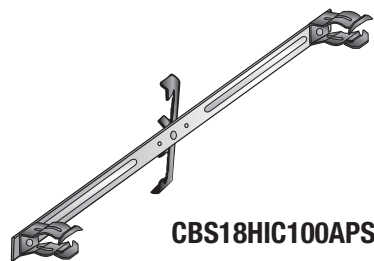

**CBS18HIC100APS**

MINERALLAC TRADITIONAL

## UNIVERSAL PIPE CLAMPS

- Universal, same pipe fits EMT, GRC/IMC and standard piping.
- Parts are made on punch press dies from hot rolled, pickled and oiled steel which conforms to the ASTM-A-366, A-575 and A-576 standards.
- Parts are zinc plated after fabrication.
- Zinc plated nut and bolt included with each part.

EMT, GRC/IMC & Standard Pipe	Part #	Std Pkg
½	<b>MSU050EG</b>	100
¾	<b>MSU075EG</b>	100
1	<b>MSU100EG</b>	100
1¼	<b>MSU125EG</b>	100
1½	<b>MSU150EG</b>	50
2	<b>MSU200EG</b>	50
2½	<b>MSU250EG</b>	50
3	<b>MSU300EG</b>	50
3½	<b>MSU350EG</b>	25
4	<b>MSU400EG</b>	25

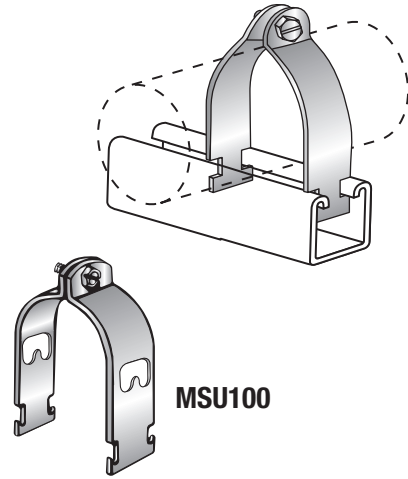

## GROUND WIRE CLIP

- Easy to use. Simply place wire into elbow, hammer nail through hole, then bend extension over nail head.
- Made from pre-galvanized steel.
- Also available in copper. Call Customer service for pricing and minimum order quantities.

Description	Part #	Std Pkg
Ground Wire Clips	<b>GWC1</b> ★	1000

★ Made in USA

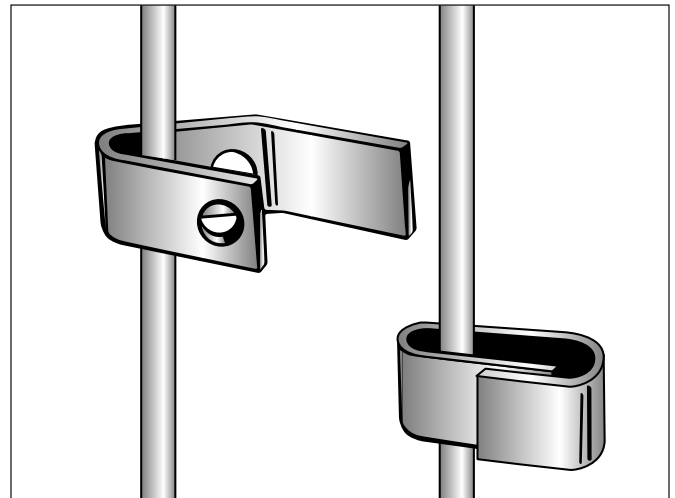
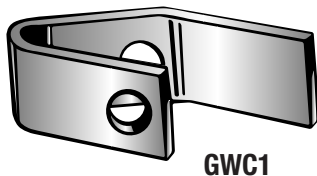

**NAIL STRAPS • COMBO EMT/RIGID • STAMPED**

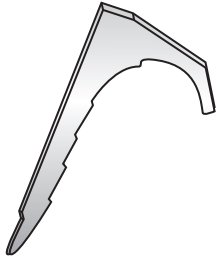

- For rigid, IMC or EMT conduit.
- Barbs on flat nail straps minimize back-out.
- Flat nail straps are made from pre-galvanized steel.

				Best Merchandising Option	
				Gravity Feed Jar	
Description	Gauge	Part #	Box Qty	Part #	Jar Qty
½ EMT or ¾ Rigid Pipe	12	90108 ★	100	90108J ★	100/600
¾ EMT or ½ Rigid Pipe	12	90112 ★	100	90112J ★	100/600
1 EMT or ¾ Rigid Pipe	12	90116 ★	100	90116J ★	100/600

★ Made in USA

**ROUND NAIL STRAPS • COMBO EMT/RIGID • GALVANIZED**

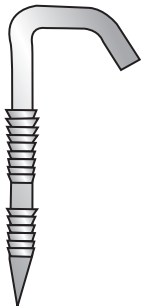

- Drives like a nail. Fast and easy to install.
- For rigid, IMC or EMT conduit.
- Knurling on shank of round nail straps minimize back out.
- Round nail straps are zinc plated after fabrication.

Description	Gauge	Part #	Box Qty
½ EMT or ¾ Rigid Pipe	12	90109 ★	100
¾ EMT or ½ Rigid Pipe	12	90113 ★	100
1 EMT or ¾ Rigid Pipe	12	90117 ★	100

★ Made in USA

**BEAM CLAMPS • UNIVERSAL**

- Used with Minerallac conduit hangers #0 to #5, bridle rings and threaded rod. Tapped for rods bottom and back except #602 (bottom only).
- Case hardened steel set screw tapped at an angle locks on beam.
- Available in zinc plated steel or made from stainless steel.

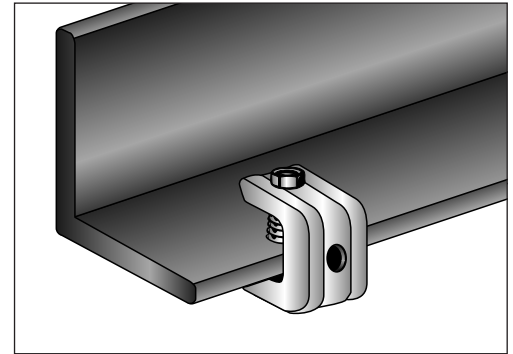
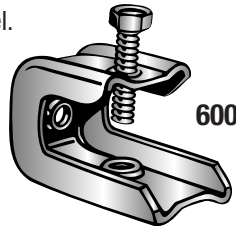
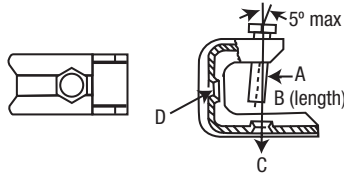

Fits Flange	Tapping	Drop Rod	Static Load Limit Bottom Hole Only	Screw Diameter A	Screw Length B	Bottom Thread C	Back Thread D	Part #	Std Pkg
<b>Zinc-Plated Steel</b>									
1/2	1/4"-20	1/4	75 lbs	1/4"-20	1	1/4"-20	1/4"-20	<b>600</b> ★	50
1/2	#10-24	#10-24	75 lbs	1/4"-20	1	10-24	10-24	<b>60010</b> ★	50
3/4	3/8" Bottom Only	3/8	200 lbs	5/16"-18	1 3/8	3/8"-16	None	<b>602</b> ★	25
3/4	3/8"-16	3/8	200 lbs	5/16"-18	1 3/8	3/8"-16	3/8"-16	<b>602B</b> ★	25
<b>Stainless Steel (Type 304)</b>									
3/4	3/8"-16	3/8	200 lbs	5/16"-18	1 3/8	3/8"-16	3/8"-16	<b>602BSS</b> ★ ♡	25

★ Made in USA   ♡ Harsh Environment Product

**BEAM CLAMPS • MALLEABLE**

- Used with Conduit Hangers, Bridle Rings and Drop Rods, 3/8" to 1/2". Tapped for rods bottom and back on all sizes.
- Malleable iron zinc plated.

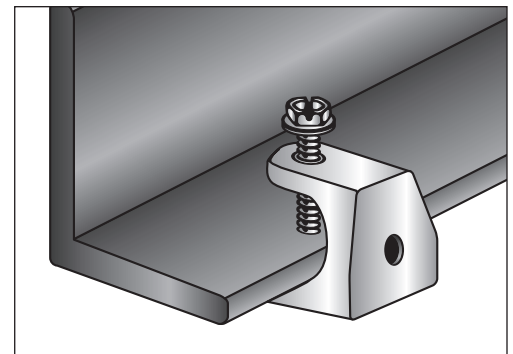
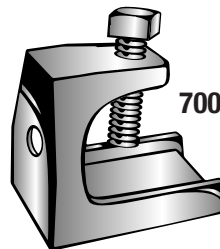
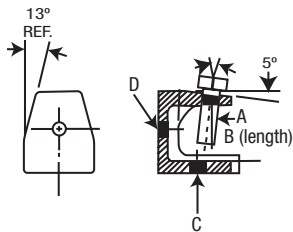

Fits Flange	Tapping	Drop Rod	Static Load Limit Bottom Hole Only	Screw Diameter A	Screw Length B	Bottom Thread C	Back Thread D	Part #	Std Pkg
<b>Zinc Plated Malleable Iron</b>									
5/8	1/4"-20	1/4	275 lbs	5/16"-18	1 1/4	1/4"-20	1/4"-20	<b>700</b>	50
3/4	#10-24	#10-24	275 lbs	1/4"-20	1 1/4	10-24	10-24	<b>70010</b>	50
3/4	5/16"-18	5/16	525 lbs	3/8"-16	1 1/4	5/16"-18	5/16"-18	<b>701</b>	25
3/4	3/8"-16	3/8	750 lbs	1/2"-13	1 1/2	3/8"-16	3/8"-16	<b>702</b>	25
7/8	1/2"-13	1/2	900 lbs	5/8"-11	1 1/2	1/2"-13	1/2"-13	<b>703</b>	25

**MINERALLAC TRADITIONAL**

**BEAM CLAMP ASSEMBLIES**

- Our #600 beam clamp with #0 through #5 Conduit Hangers attached.
- Offered with or without nut and bolt attached.
- Zinc plated steel.

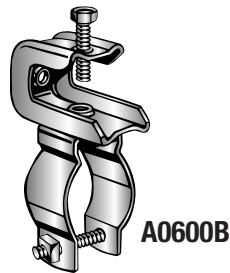
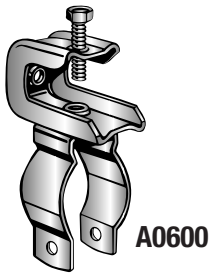
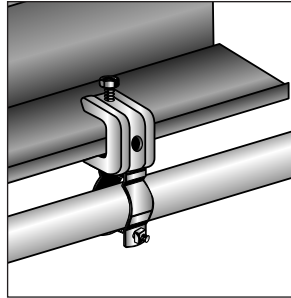

Fits EMT	Fits Rigid/MC	Part #	Std Pkg
<b>Zinc Plated Without Bolt</b>			
1/2	3/8-1/2	<b>A0600</b> ★	100
3/4	3/4	<b>A1600</b> ★	100
1	1	<b>A2600</b> ★	100
1 1/4	—	<b>A2-1/2 600</b> ★	100
1 1/2	1 1/4	<b>A3600</b> ★	100
—	1 1/2	<b>A4600</b> ★	50
2	2	<b>A5600</b> ★	50
<b>Zinc Plated With Bolt</b>			
1/2	3/8-1/2	<b>A0600B</b>	100
3/4	3/4	<b>A1600B</b>	100
1	1	<b>A2600B</b>	100
1 1/4	—	<b>A2-1/2 600B</b>	100
1 1/2	1 1/4	<b>A3600B</b>	100
—	1 1/2	<b>A4600B</b>	50
2	2	<b>A5600B</b>	50

★ Made in USA

**FLANGE/T-BAR CLIP • TWO-PIECE**

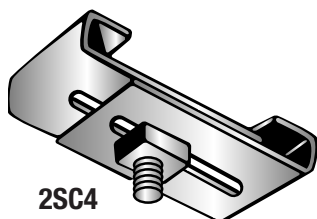
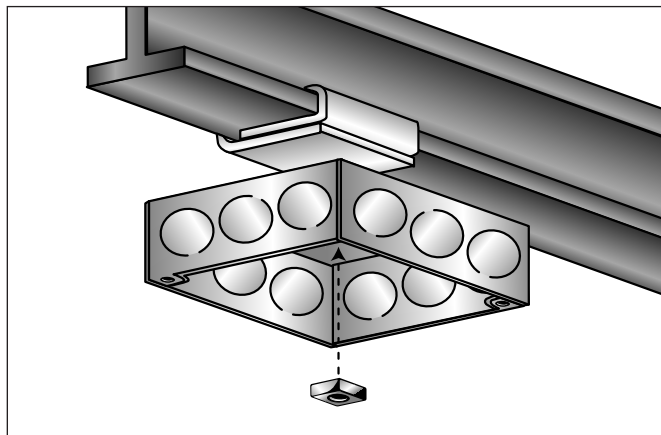

**Static Load Limit: 100 lbs**

- Fits flanges from 1 5/8" to 2 5/8" width and up to 1/4" thick.
- 1/4"-20 stud with nut.
- Zinc plated steel.

Fits Conduit	Part #	Std Pkg
<b>Zinc Plated</b>		
Fits 1 5/8" to 2 5/8" Wide Flanges; Up to 1/4" Thick	<b>2SC4</b>	100

**MINERALLAC TRADITIONAL**

## BEAM MOUNT CONDUIT & BOX SUPPORT ASSEMBLY

- Provides conduit support on both sides of electrical box.
- Attaches to beam flanges from 1/8" to 1/2" thick.
- Made from pre-galvanized steel with Black Claw™ spring steel fasteners riveted to part.

Mount 4" Square Boxes		Part #	Std Pkg
Conduit Size	Flange Thickness		
3/8	1/8-1/4	<b>CBS18KC3818</b> ★	25
3/8	5/16-1/2	<b>CBS18KC38516</b> ★	25
1/2-3/4	1/8-1/4	<b>CBS18KC123418</b> ★	25
1/2-3/4	5/16-1/2	<b>CBS18KC1234516</b> ★	25
1	1/8-1/4	<b>CBS18KC118</b> ★	25
1	5/16-1/2	<b>CBS18KC1516</b> ★	25

★ Made in USA

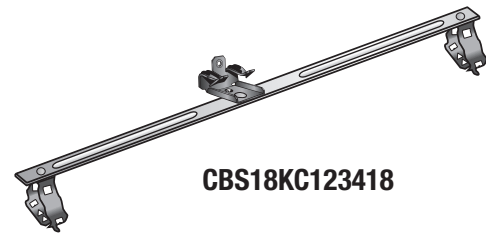
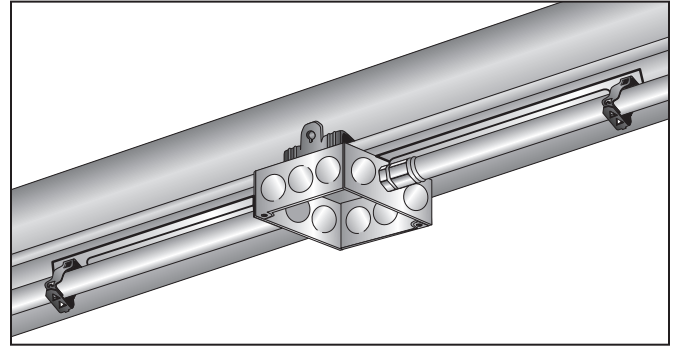

**CBS18KC123418**

- Provides conduit support on both sides of electrical box.
- Attaches to beam flanges from 1/8" to 1/2" thick.
- Made from pre-galvanized steel with Black Claw™ spring steel fasteners riveted to part.

Mount 4" Square Boxes		Part #	Std Pkg
Conduit Size	Flange Thickness		
1/2" EMT	1/8-1/4	<b>CBS18HIC5018</b> ★	25
1/2" EMT	5/16-1/2	<b>CBS18HIC50516</b> ★	25
3/4" EMT or 1/2" Rigid	1/8-1/4	<b>CBS18HIC7518</b> ★	25
3/4" EMT or 1/2" Rigid	5/16-1/2	<b>CBS18HIC75516</b> ★	25
1" EMT or 3/4" Rigid	1/8-1/4	<b>CBS18HIC10018</b> ★	25
1" EMT or 3/4" Rigid	5/16-1/2	<b>CBS18HIC100516</b> ★	25

★ Made in USA

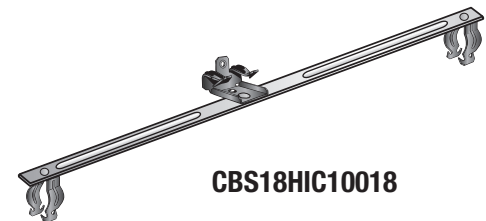
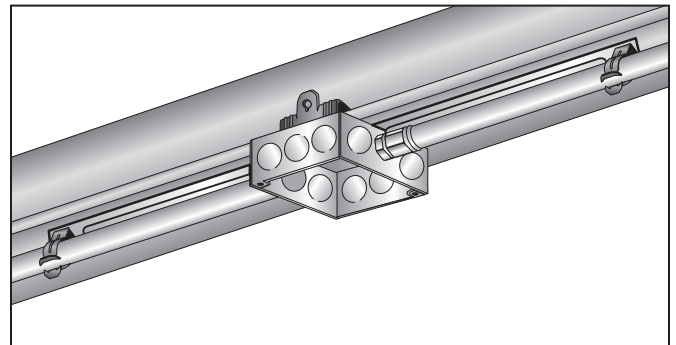

**CBS18HIC10018**

**BOX MOUNTING BRACKET**

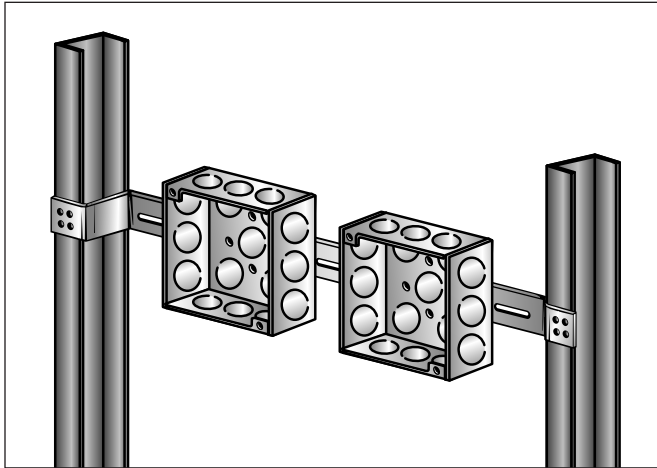

- Supports electrical boxes located between studs on 16" or 24" centers. Boxes attach using self-tapping screws.
- Made from pre-galvanized steel.

Description	Part #	Std Pkg
1½" Box to Studs on 16" Centers	<b>BMB16</b> ★	50
2⅛" Box to Studs on 16" Centers	<b>BMB16D</b> ★	50
1½" Box to Studs on 24" Centers	<b>BMB24</b> ★	50
2⅛" Box to Studs on 24" Centers	<b>BMB24D</b> ★	50

★ Made in USA

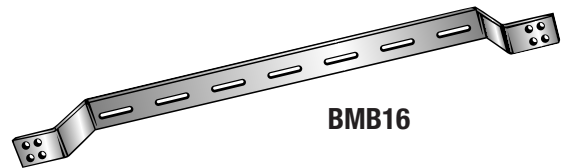

MINERALLAC TRADITIONAL

**BOX TO BAR FASTENER**

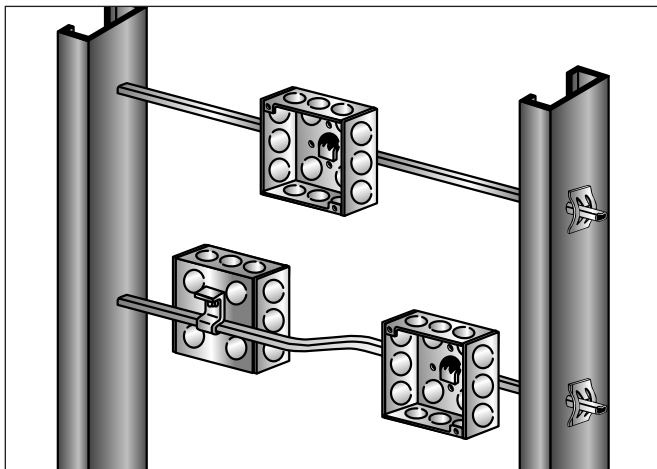

- Black Claw™ Spring Steel hardware is included.
- Bars made from pre-galvanized steel.

Description	Part #	Std Pkg
1 Straight 26"-Long Bar 1 BBC, 2 BSC	<b>BAR</b> ★	50
1 Offset 26"-Long Bar 2 BBC, 2 BSC	<b>RBAR</b> ★	50

★ Made in USA

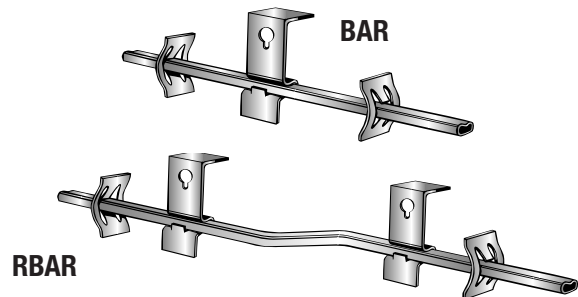



## OUTLET RETAINER

- Mounts standard outlets and wall switches in oversize openings, lending stability and preventing broken cover plates.
- Made from pre-galvanized steel.

Description	Part #	Std Pkg
Mounts Standard Outlets In Oversize Openings	<b>OR</b> ★	100

★ Made in USA

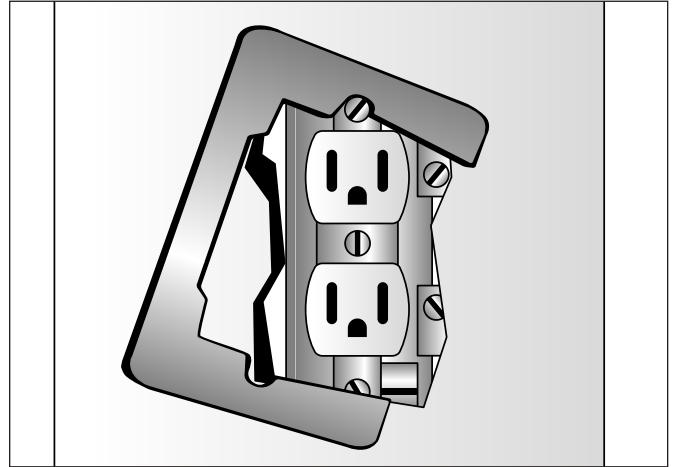
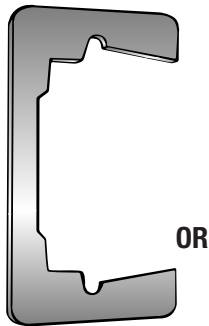

## BOX MOUNTING BRACKET

- Bracket supports electrical boxes from floor or channels.
- Can be used at three heights.
- Made from pre-galvanized steel.

Description	Part #	Std Pkg
Break-A-Way Feature for 12", 16", 18" Lengths	<b>BS18</b> ★	50

★ Made in USA

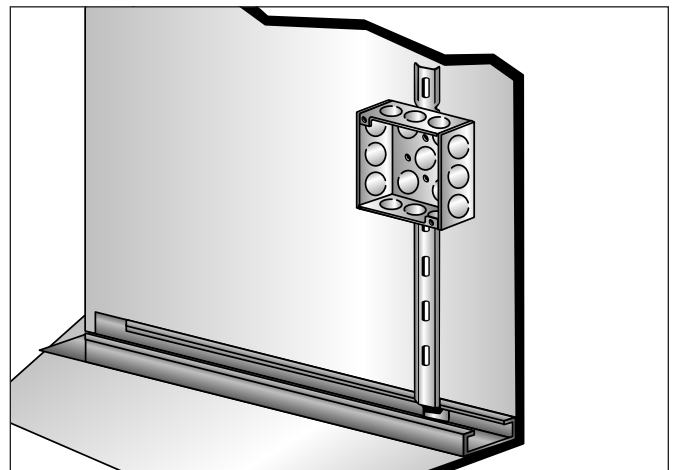

**BOX STABILIZER SUPPORT**

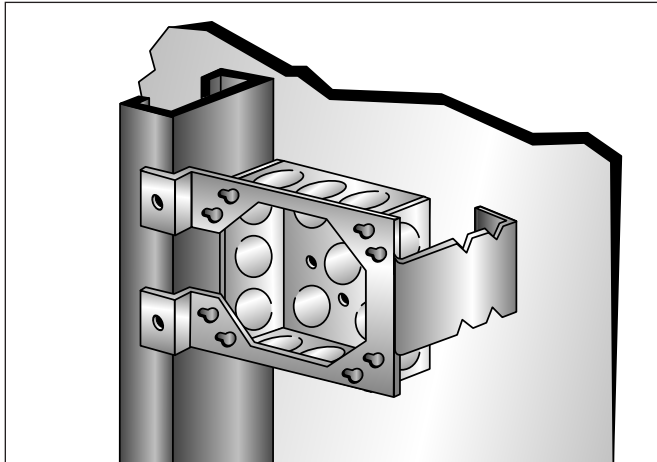

- Screw attached support for electrical boxes.
- Made from pre-galvanized steel.

Description	Part #	Std Pkg
Box Support for 2½" and 3½" Wood or Metal Studs	<b>FB023</b> ★	100
Box Support for 2½", 3½" and 4" Wood or Metal Studs	<b>FB0234</b> ★	100
Box Support for 6" Wood or Metal Studs	<b>FB06</b> ★	100

★ Made in USA

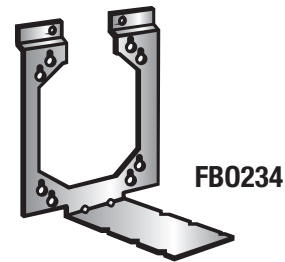

MINERALLAC TRADITIONAL

**BOX SUPPORTS • SCREWLESS DESIGN • GALVANIZED STEEL**

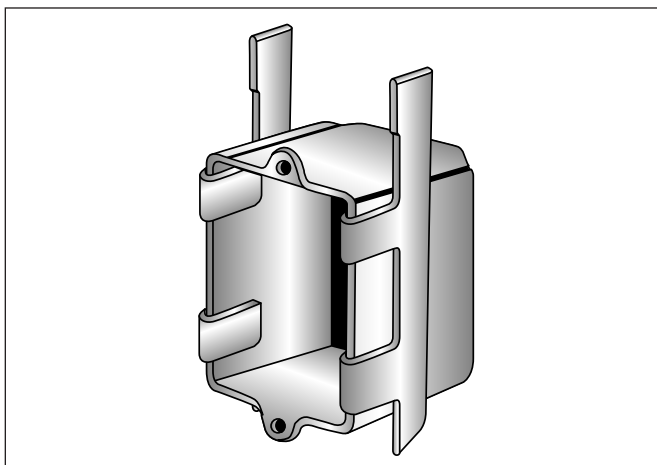

- Holds switch boxes and outlets firmly in place.
- Quick installation.
- One-piece break-away design.
- Box is supported by drywall. No stud is necessary.
- Prevents box from pulling out of drywall.
- Made from pre-galvanized steel.

Description	Part #	Std Pkg
Secures Electrical Box to Finished Drywall	<b>BST</b> ★	100 Sets

★ Made in USA

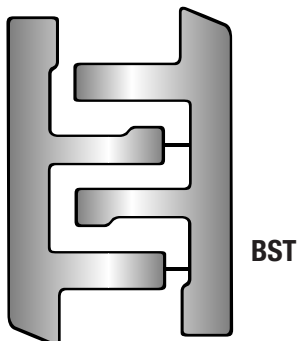

## PLASTIC FAR SIDE BOX SUPPORT

- No tools required. Mounts quickly in the back of the box. Just push in and snap tight.
- Designed for 3 5/8" steel studs.
- May be used on standard 1 1/2" or 2 1/8" deep boxes.

Description	Part #	Std Pkg
Designed for use with 3 5/8" steel studs. May be used on standard 1 1/2" boxes or 2 1/8" deep boxes.	<b>DLS1</b>	100

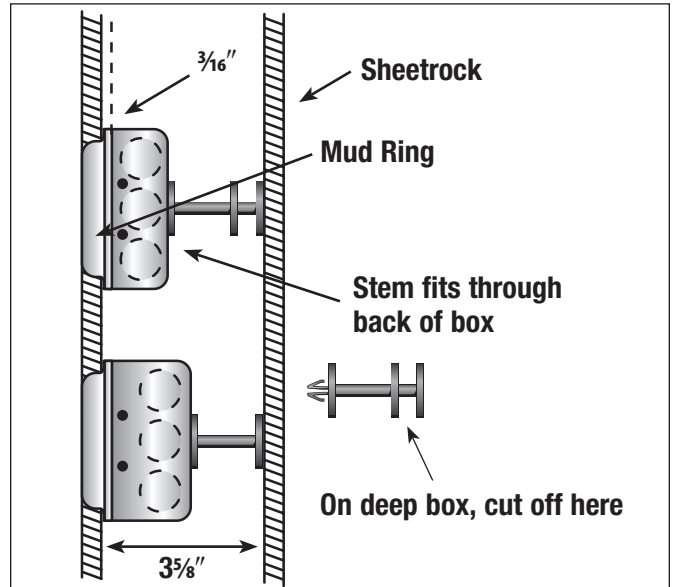
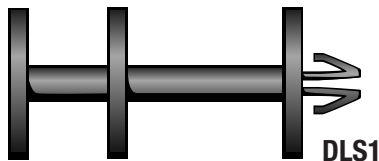

## BOX TO T-BAR FASTENER

- Snap-on 24" span box hanger with dual height adjustment allows flush or 3/4" offset mount.
- Pre-galvanized steel with Black Claw™ spring steel hardware included.

Description	Part #	Std Pkg
24"-Long Box Hanger, 1 BBC Mounting Clip with Screw	<b>TBAR</b>	50

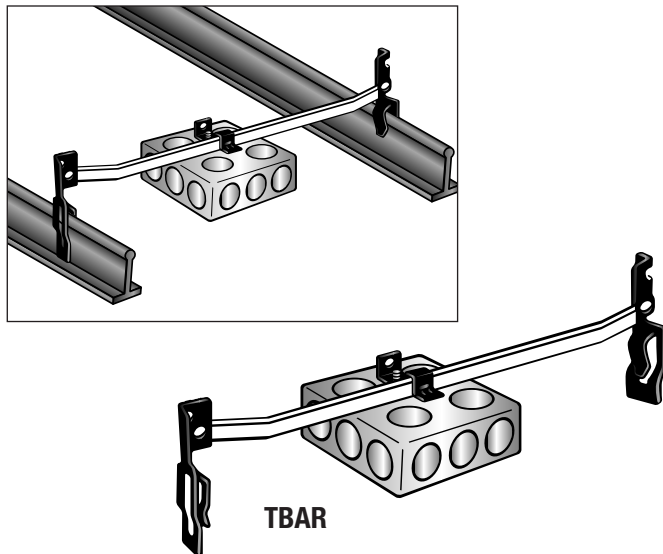

## LIGHTING SUPPORT ASSEMBLY

- Snap-on 24" fixed span with adjustable fixture position.
- Installed with screwdriver.
- Pre-galvanized steel with Black Claw™ spring steel hardware.

Description	Part #	Std Pkg
Fits LIGHTOILER 5 and CALCULITE® Series Fixtures	<b>LSBAR</b> ★	25 Sets

★ Made in USA

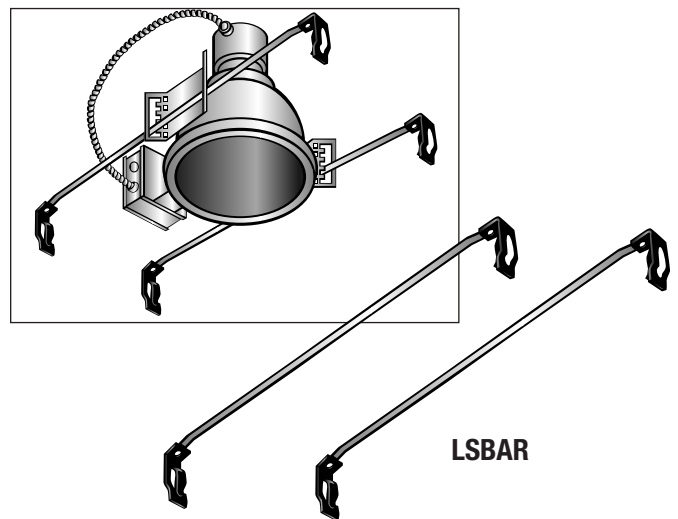

### T-BAR HANGER • TWO PIECE

- Mounts fixtures or boxes to 1" T-bar with Ultimate Static Load Limit of 75 lbs.
- Stud is flat head, square shoulder carriage bolt which will not turn when positioned in slot. Assembled with 1" OD wing nut washer.

Description	Part #	Std Pkg
Has 1/4"-20 x 5/8" Stud with Wing Nut and Washer	<b>SCT2</b>	100

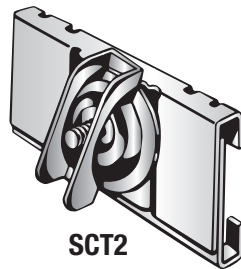
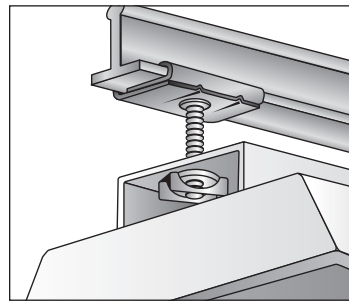

### T-BAR SCISSOR CLIPS

- Two-piece zinc plated clip used for mounting fixtures or boxes to 1" T-bar with Ultimate Static Load Limit of 100 lbs.
- Includes wing nut washer.

For Use With		Part #	Std Pkg
Stud Length	T-Bar		
5/8"	1"	<b>SCX1W</b> ★	50
2"	1"	<b>SCX1XL</b> ★	50

★ Made in USA

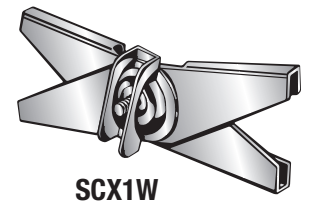
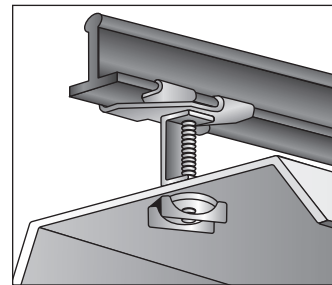

MINERALLAC TRADITIONAL

### T-BAR DROP WIRE CLIP

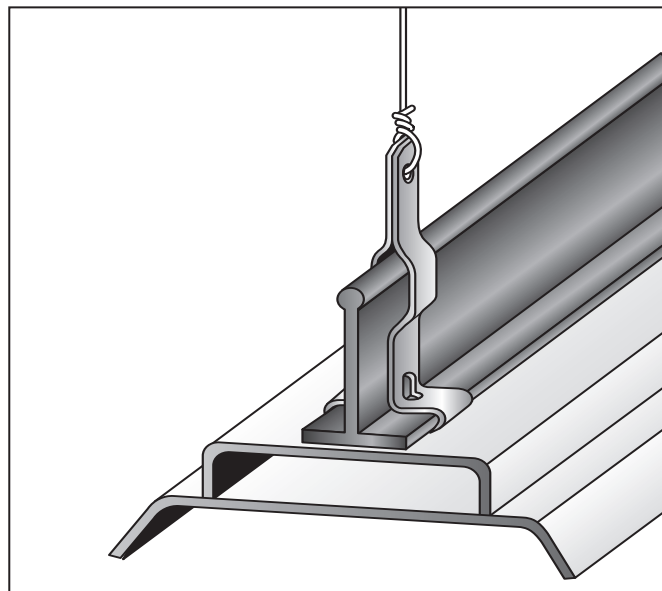

- These pre-galvanized clips support fixtures transmitting the weight of the fixture directly to the building structure, thus relieving the tee grid from any load stress. Also adds rigidity and support for truer alignment of the tee grid. Made from one-piece construction to accommodate various styles of tee grid.
- Includes wing nut washer.

For Use With		Part #	Std Pkg
Stud Length	T-Bar		
5/8"	1"	<b>DWC1</b>	50

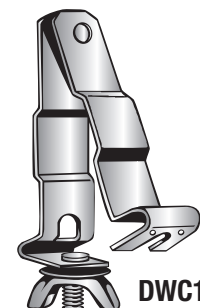

**CABLE SUPPORT • J-HOOKS**

**Another Solution for Today's Challenging Installations!**

The new 2" J-Hook cable support system, designed to be versatile, can be attached to a wide variety of structures using beam clamps, clips, and many other support components available from Minerallac. The wide-base support eliminates the undesirable impact of point-loads that can cause band-width deterioration and damage to Category 5 and 6, fiber-optic, and other sensitive cables. This unique system is labor and time-saving—another efficient method of cable installation!

**J-Hook Cable System**

- Cost effective alternative to expensive cable tray.
- Accommodates Category 5 and 6, fiber-optic and interduct.
- Provides support without stress to sensitive voice/data cables.
- Continuous wide-base radius supports natural curve of cable, eliminating kinking, bending and crimping.
- Cable wire retainer is supplied with every part.

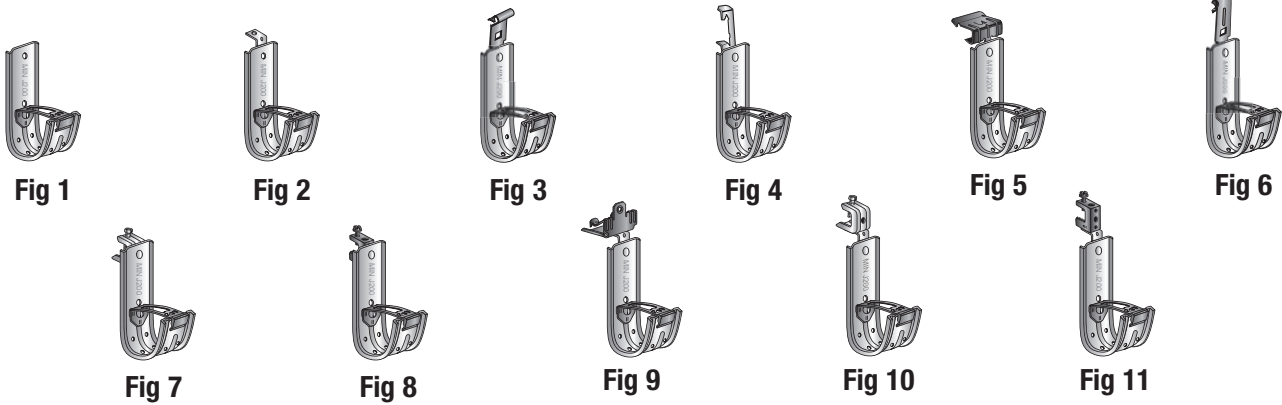
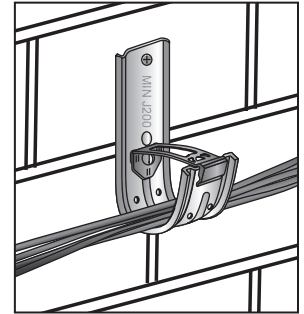

Description	Fig	Part #	Std Pkg
2" J-Hook	1	J200 ★	50
2" J-Hook with Bracket	2	J200B ★	50
Hammer On – 1/6–1/4 Angled Z Purlin	3	J200ABC25 ★	50
Fits #12 Wire Thru 3/8" Rod and 1/8–3/8 Flange	4	J200APS ★	50
Hammer On – 1/8–1/4 Flange	5	J200SFC18 ★	50
Hammer On – 5/16–1/2 Flange	5	J200SFC516 ★	50
Hammer On – 9/16–3/4 Flange	5	J200SFC916 ★	50
Hammer On – 1/6–1/4 Vertical Flange	6	J200VBC25 ★	50
Screw On – Up To 1/2" Flange	7	J200600 ★	50
Screw On – Up To 1/2" Flange	8	J200500	50
Hammer On – 1/8–1/4 Flange	9	J200BBC18 ★	50
Hammer On – 5/16–1/2 Flange	9	J200BBC516 ★	50
Hammer On – 9/16–3/4 Flange	9	J200BBC916 ★	50
Screw On – Up To 1/2" Flange	10	J200B600 ★	50
Screw On – Up To 1/2" Flange	11	J200B500	50

★ Made in USA

MINERALLAC TRADITIONAL

**CABLE SUPPORT • BRIDLE RINGS**

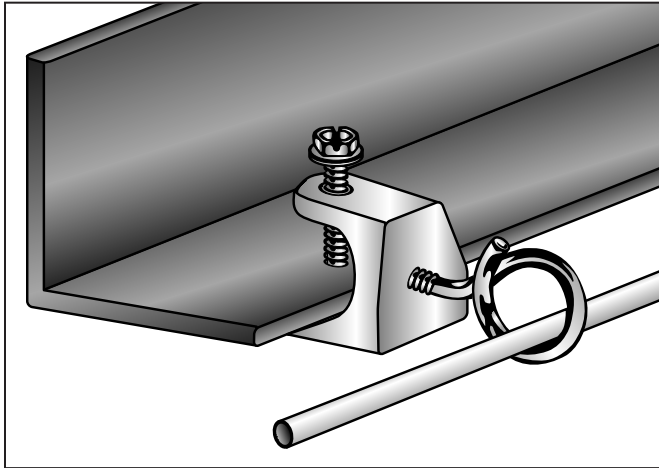

- Supports communications cable and other low voltage uses. Can be used with Minerallac Beam Clamps.
- Zinc plated steel.
- Also available in stainless steel. Call Customer service for pricing and minimum order quantities.

Ring Size	Thread	Part #	Std Pkg
1" Diameter	10-24	<b>634R</b> ★	100
1½" Diameter	¼"-20	<b>646R</b> ★	100
2" Diameter	¼"-20	<b>648R</b> ★	100
4" Diameter	¼"-20	<b>654R</b> ★	50

★ Made in USA

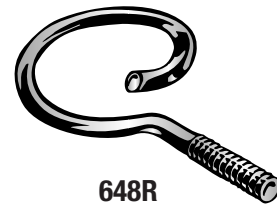

**648R**

MINERALLAC TRADITIONAL

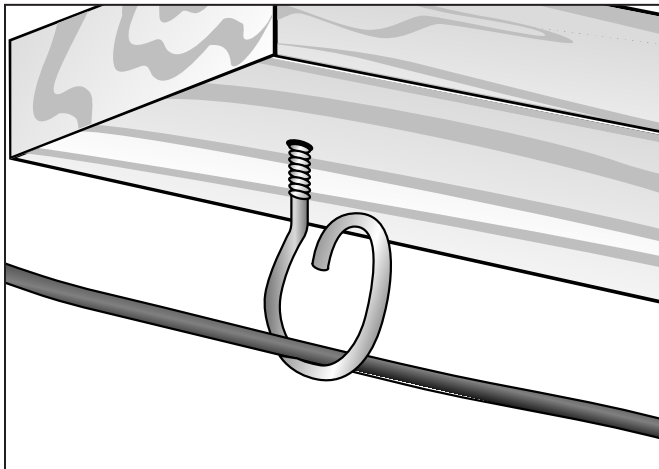

- Supports communications cable and other low voltage uses from wood beams.
- Zinc plated steel.
- Also available in stainless steel. Call Customer service for pricing and minimum order quantities.

Ring Size	Thread	Part #	Std Pkg
1" Diameter	⅜	<b>634RW</b> ★	100
1½" Diameter	¼	<b>646RW</b> ★	100
2" Diameter	¼	<b>648RW</b> ★	100

★ Made in USA



**648RW**

## CABLE SUPPORT • BRIDLE RINGS

- Cost effective alternative to cable tray.
- Wide surface saddle provides support without stress for Category 5 and 6, fiber-optic and other sensitive voice/datacom cables.
- Available as assembled units or saddle only for retrofit.
- Saddle molded onto 4" bridle ring.

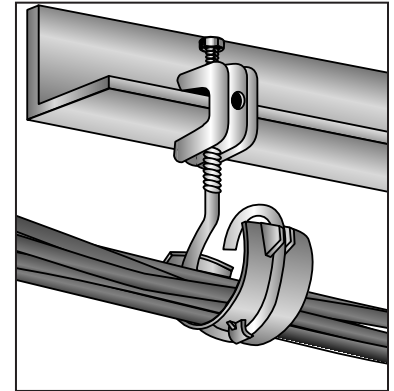

Saddle Assembly Description	Part #	Std Pkg
<b>Mechanical Thread</b>		
1½" Bridle Ring with Saddle	<b>646RS</b> ★	50
2" Bridle Ring with Saddle	<b>648RS</b> ★	50
4" Bridle Ring with Saddle	<b>654RS</b> ★	50
<b>Lag Thread</b>		
1½" Bridle Ring with Saddle	<b>646RWS</b> ★	50
2" Bridle Ring with Saddle	<b>648RWS</b> ★	50

Saddle Only Description	Part #	Std Pkg
Snaps into 1½" Bridle Ring	<b>BRS15</b> ★	100
Snaps into 2" Bridle Ring	<b>BRS2</b> ★	100

★ Made in USA

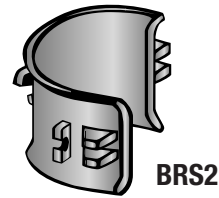

**BRS2**

US Patent No. 6,325,338

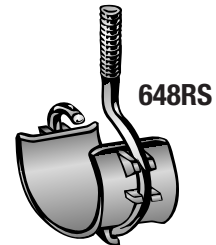

**648RS**

## UNIVERSAL PLASTIC METAL STUD GROMMET

- Protects wires from damage by metal studs.
- Easy to install—no tools required.
- Complies with 2011 NEC Article 300.4B/(1).

Description	Part #	Std Pkg
Grommets for Metal Studs	<b>G100</b> ★	100

★ Made in USA



**G100**

**CABLE PROTECTION • NAIL PLATES**

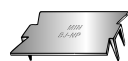

**BJNP**



**NP6**



**BJNPH**



**NP6M**



**NP3**



**NP12**



**NP18**

- Protects data/com, PVC plumbing and electrical from punctures by nails or screws.
- Styles with teeth attach to wood studs with hammer.
- Styles with holes attach to wood or metal studs using nails or screws and a hammer or screwdriver.
- Required for compliance with 2011 NEC Article 300.4(A) or Plumbing Code 305.8.
- Constructed from pre-galvanized steel for corrosion resistance.

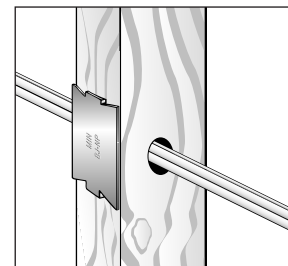

Size (L x W)	Part #	Std Pkg
2½ x 1½	<b>BJNP</b> ★	100
2½ x 1½	<b>BJNPH</b> ★	100
3 x 1½	<b>NP3</b> ★	100
6 x 1½	<b>NP6</b> ★	50
6 x 1½	<b>NP6M</b> ★	100
12 x 1½	<b>NP12</b> ★	50
18 x 1½	<b>NP18</b> ★	50

★ Made in USA

**NAIL PLATES (SAFETY PLATES) • 16 & 18 GAUGE**

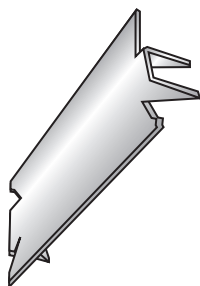

- Prevents drills and fasteners from penetrating framed-in cables and plastic pipes.
- Required for 2011 NEC Article 300.4(A) or Plumbing Code 305.8.

Length (L x W)	Gauge	Part #	Box Qty	Bucket Qty
3 x 1½	16	<b>90100</b> ★	100	—
3 x 1½	16	<b>90500</b> ★	500	—
3 x 1½	16	<b>90505</b> ★	—	500
5 x 2	16	<b>90600</b> ★	100	—
5 x 3	16	<b>90605</b> ★	100	—

★ Made in USA



## CABLE SUPPORT • D-RINGS

- Used to support multiple cable runs.
- Smooth non-conductive surface won't damage cable.
- Lower cost than steel distribution rings (D-rings).
- Parts made from high-strength, UV stabilized non-metallic composite.

Ring Size (H x W) Inside Opening	Part #	Std Pkg
2¼ x 2	DR20 ★ ♣	50
3¼ x 3	DR30 ★ ♣	25
3¼ x 5	DR40 ★ ♣	10

★ Made in USA   ♣ Harsh Environment Product

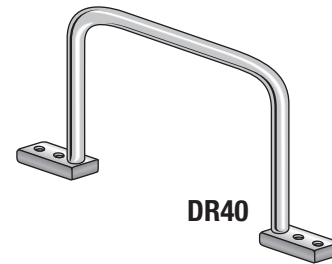
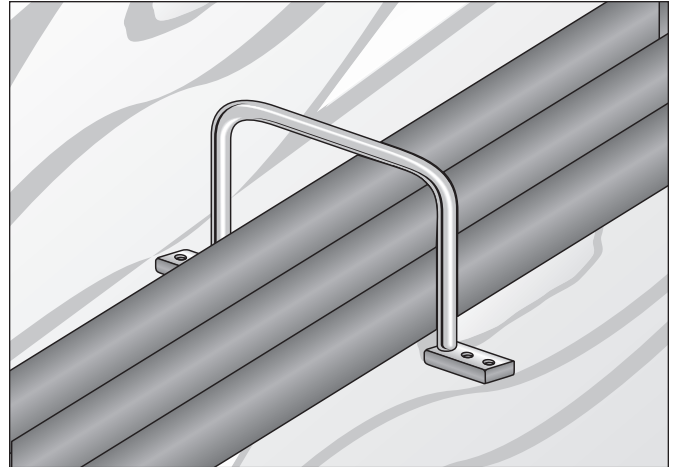

## LOW VOLTAGE MOUNTING BRACKET

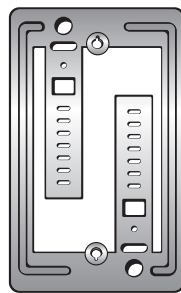
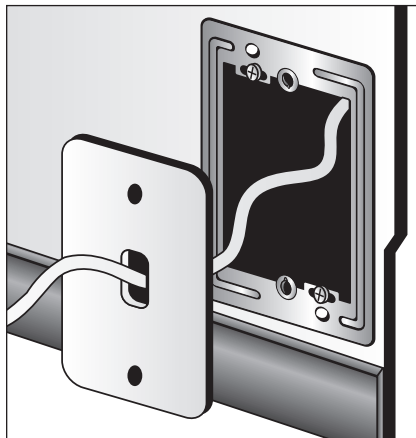

WBF1

- Provides base for securing communications lines without use of electrical box. Mounts standard plate.
- Hardware included.
- Made from pre-galvanized steel.

Description	Part #	Std Pkg
Mounts Standard Low Voltage Plates	WBF1	100

STOVE BOLT WITH NUT

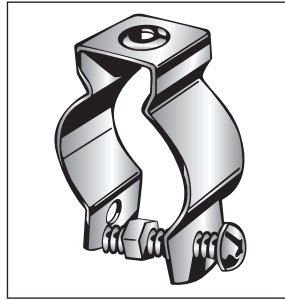
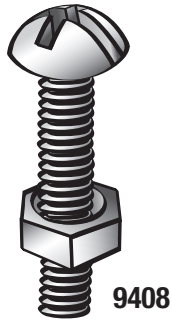

- Available in zinc plated steel, aluminum or stainless steel.

Thread	Length	Part #	Std Pkg
Zinc Plated			
¼"-20	1	<b>25516</b>	100
¼"-20	1¼	<b>25520</b>	100
¼"-20	1½	<b>25524</b>	100
Aluminum			
¼"-20	1¼	<b>9410A</b> ♣	100
Stainless Steel (18-8)			
¼"-20	1	<b>9408S</b> ♣	100
¼"-20	1¼	<b>9410S</b> ♣	100
¼"-20	1½	<b>9412S</b> ♣	100

♣ Harsh Environment Product

WING NUT WASHER

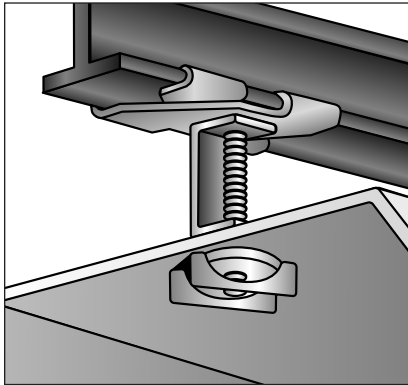

14WNW

- Made from zinc plated steel.

Wing Nut Washer Combo	Part #	Std Pkg
Fits ¼"-20 Bolt	<b>14WNW</b> ★	100

★ Made in USA

## PERFORATED STRAPPING

- Used for hanging large size pipe or duct.
- Pre-galvanized steel.
- Other lengths of 0.035" x 3/4" and 0.050" x 7/8" perforated strapping available. Call Customer service for pricing and minimum order quantities.

Perforated Strap	Part #	Std Pkg
Pre-Galvanized 0.035" x 3/4"		
10' Coils	<b>410C</b> ★	100'
100' Coils	<b>410C100</b> ★	100'
Pre-Galvanized 0.050" x 7/8"		
10' Coils	<b>478C</b> ★	100'

★ Made in USA

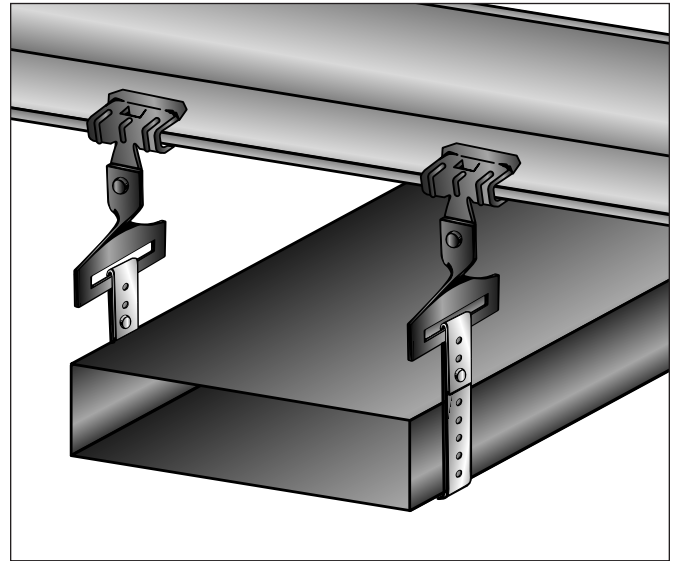
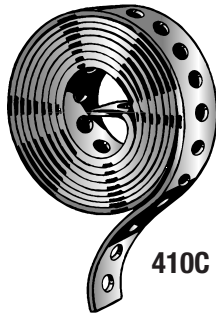

## STUD CLIP ADAPTER

- Right angle fixture for attaching "S" hooks, or Jack Chain to drop rods, scissor clips or stud clips.
- Used with SCX1X, 2SC4, SCT3 and SCT2.
- Zinc plated steel.

Description	Part #	Std Pkg
For "S" Hooks or Fixture Chain	<b>SCH48</b> ★	100

★ Made in USA

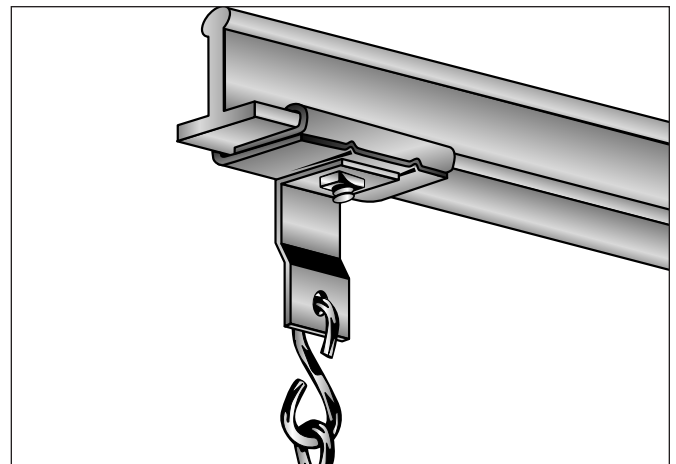

**BRACKETS**

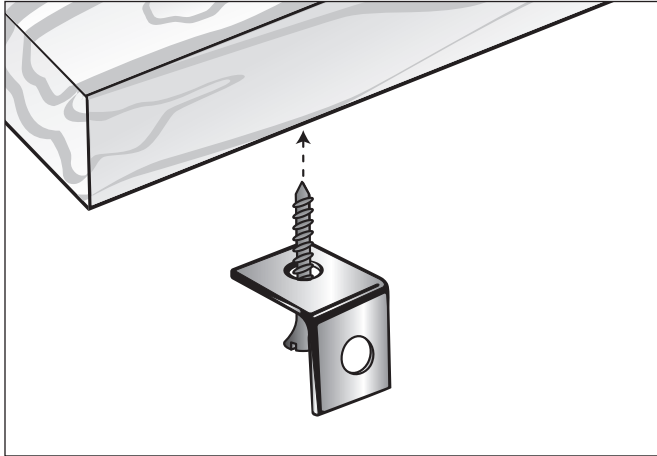

- These components, used riveted to other Minerallac products, are available separately for a variety of applications.
- Pre-galvanized steel.

Bolt Size	Part #	Std Pkg
<b>Angle Bracket</b>		
1/4" Mounting Hole	<b>BA</b> ★	100
1/4" Mounting Hole with Torx Hole at Other End	<b>PBA</b> ★	100
<b>Offset Bracket</b>		
1/4" Mounting Hole	<b>BO</b> ★	100

★ Made in USA

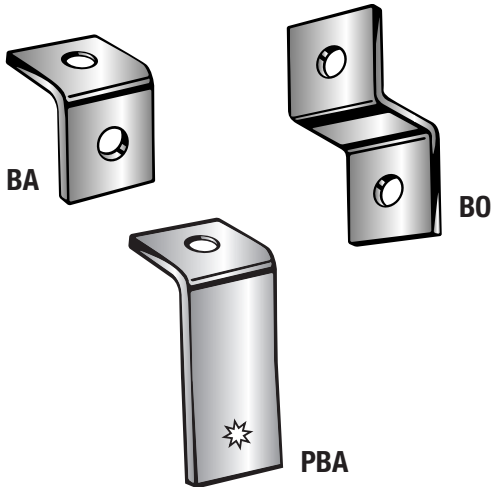

MINERALLAC TRADITIONAL

**BAR JOIST WASHERS**

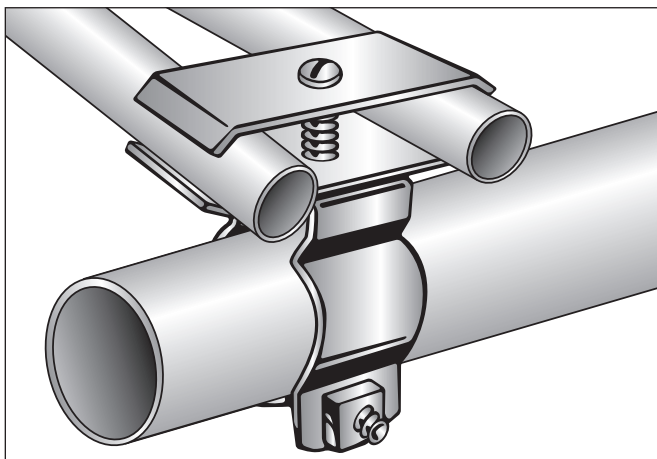

- Durable, rugged washers simplify and speed up the job of hanging conduit from bar joists.
- Zinc plated steel.

Bolt Size	Part #	Std Pkg
1/4	<b>BJW4</b> ★	50 Pr
3/8	<b>BJW6</b> ★	50 Pr

★ Made in USA

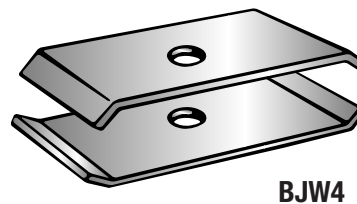

# Black Claw™

By **Minerallac** Company

## Strong, Swift and Efficient

Our Black Claw™ line of premium fasteners is constructed from high-carbon steel that has been engineered and manufactured to ensure a tight, secure “claw grip” on flanges, conduit, cable, studs and T-bars. Winning rave reviews by contractors, these products are hailed for their strength and efficient installation.

**234-240** Conduit Cable

**241-244** Hangers

**245-249** Beam/Purlin

**250-253** Metal Stud

**254-256** Acoustical

**257** Voice/Data & Low Voltage

**258** Hardware/Accessories

**259-260** Compatability & Size  
Reference Charts

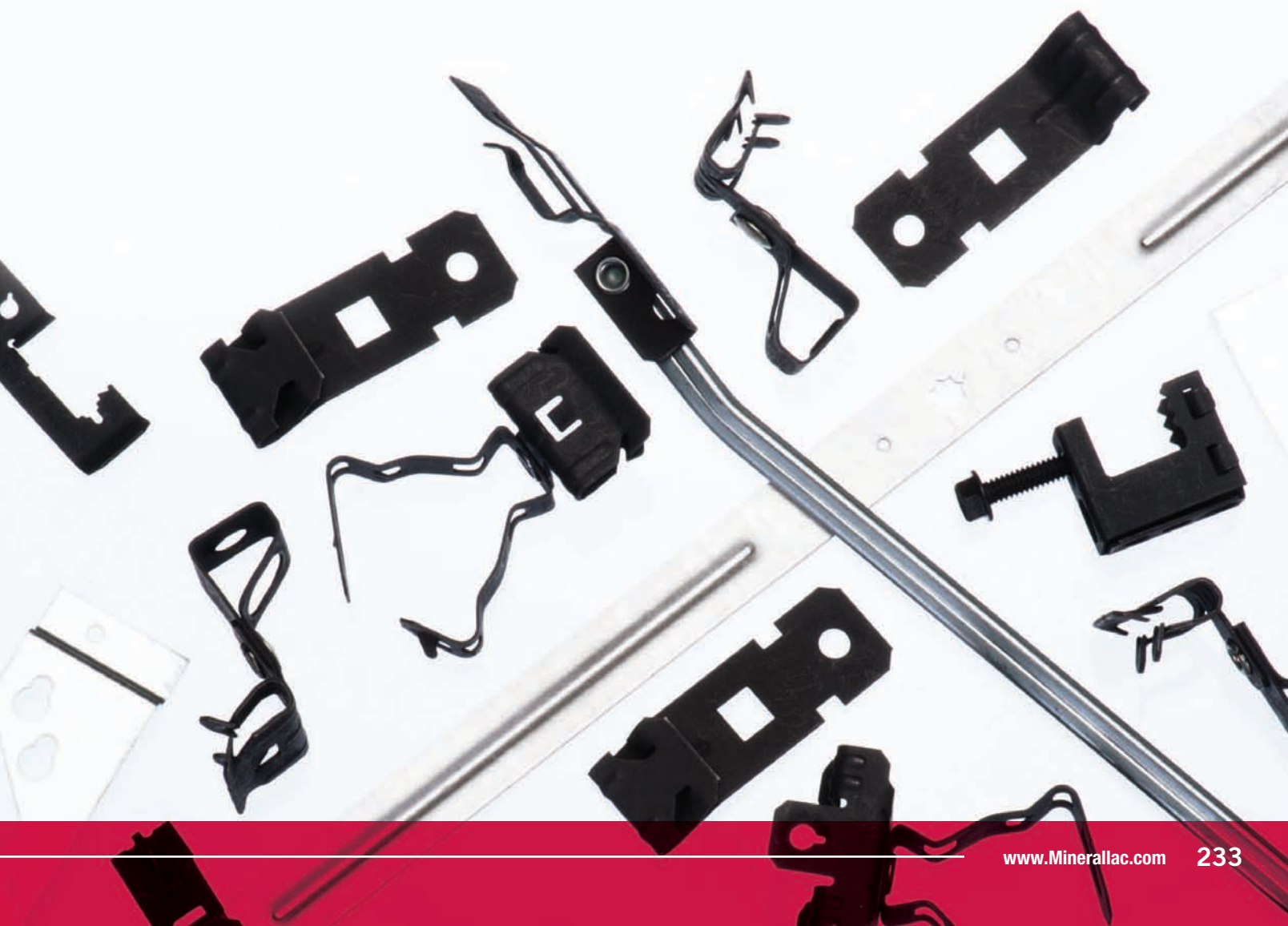

## CONDUIT CLIP

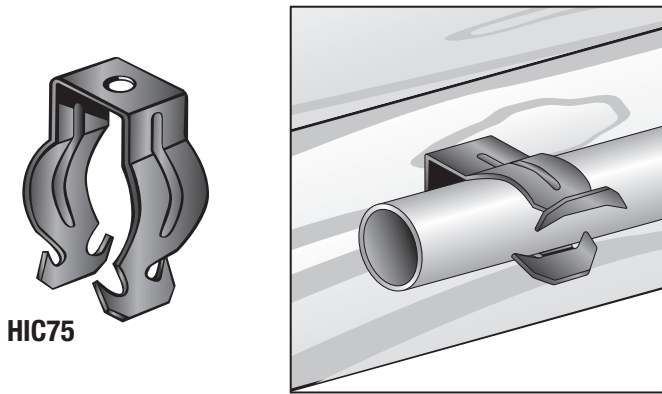

HIC75

**Ultimate Static Load Limit:**  
**25lbs Vertical Position**  
**15lbs Horizontal Position**

- No fastener required.

Fits EMT	Fits Rigid/IMC	Part #	Std Pkg
1/2	—	HIC50 ★	100
3/4	1/2	HIC75 ★	100
1	3/4	HIC100 ★	100

★ Made in USA

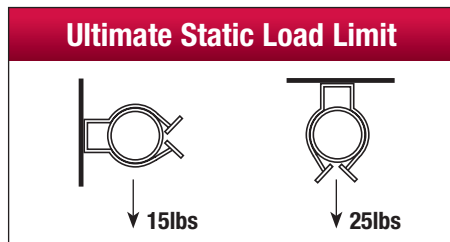

BLACK CLAW

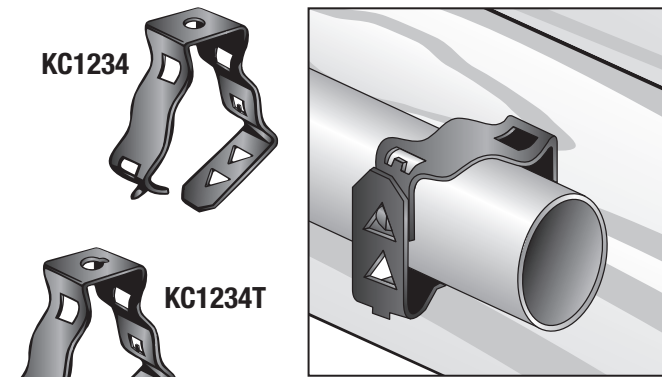

KC1234

KC1234T

**Static Load Limit:**  
**100lbs Vertical Position**  
**25lbs Horizontal Position**

- No fastener required.
- 3/8", 1/2" and 3/4" available both non-keyholed and keyholed for 1/4"-20 screw.

Fits Conduit	Part #	Std Pkg
3/8	KC38 ★	100
1/2, 3/4	KC1234 ★	100
1	KC1 ★	100
1 1/4	KC114 ★	100
1 1/2	KC112 ★	100
2	KC2 ★	100

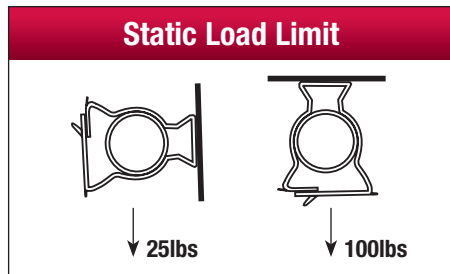

With Thread Impression for 1/4"-20	Part #	Std Pkg
3/8	KC38T ★	100
1/2, 3/4	KC1234T ★	100

★ Made in USA

## CONDUIT TO CONDUIT TRAPEZE ASSEMBLY

- No fastener required.
- Designed to quickly secure one conduit run to another.

**NOTE:** Top conduit to be used for support only, not a raceway.

Connects Conduit		Part #	Std Pkg
EMT	Rigid/IMC		
½ to ½	—	<b>HIC5050</b> ★	100
½ to ¾	—	<b>HIC5075</b> ★	100
¾ to ¾	½ to ½	<b>HIC7575</b> ★	100

★ Made in USA

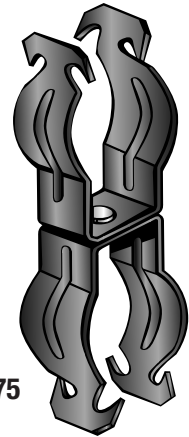
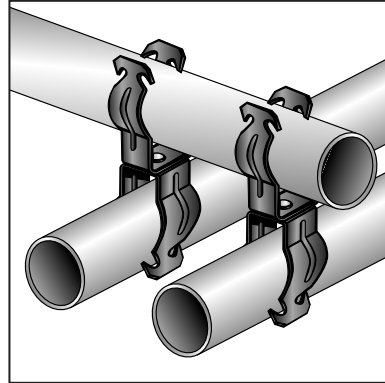

**HIC7575**

- Total load of trapeze must not exceed 100lbs.
- No fastener required.
- Designed to quickly secure one conduit run to another.

Connects Conduit	Part #	Std Pkg
¾ to 1	<b>KC38KC1</b> ★	100
¾ to ½ or ¾	<b>KC38KC1234</b> ★	100
½ or ¾ to ½ or ¾	<b>KC1234KC1234</b> ★	100

★ Made in USA

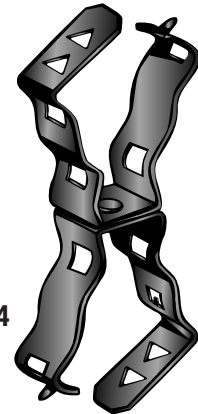
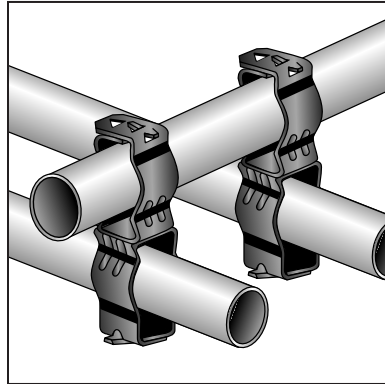

**KC1234KC1234**

## CABLE CLIP

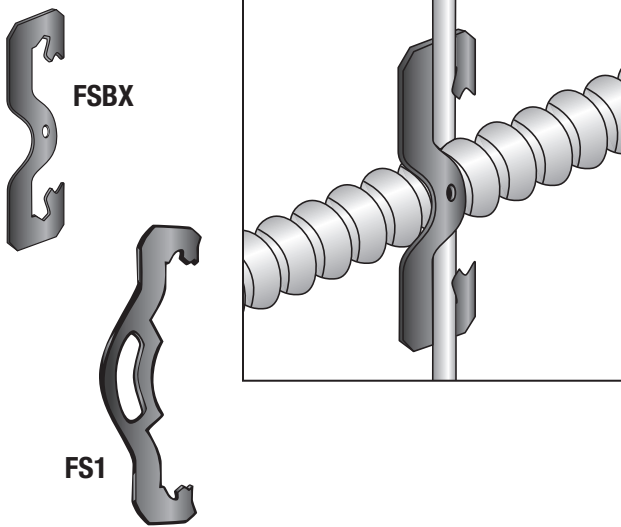

- Clip for MC, AC, or BX. Supports cable from #12 to #8 wire in horizontal or vertical position. O.D.'s from .433 to .535.

**NOTE:** These products are designed for positioning only. No load rating.

Cable Size	#12 Wire	#10 Wire	#8 & #9 Wire	Std Pkg
14-2 Cable	FSBX ★	FSBX ★	FSBX ★	100
14-3 Cable	FSBX ★	FSBX ★	FSBX ★	100
12-2 Cable	FSBX ★	FSBX ★	FSBX ★	100
12-3 Cable	FSBX ★	FS1 ★	FS1 ★	100

★ Made in USA

## CONDUIT CLIP

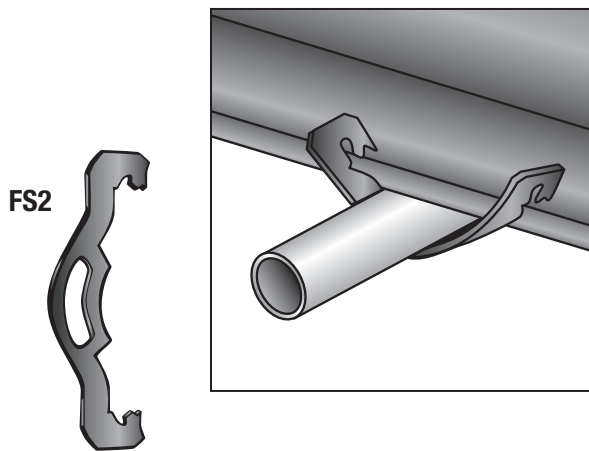

- Supports conduit and all types of cable from rods or flanges.

Conduit Size	#10 & #12 Wire	#8 & #9 Wire	3/16" to 1/4" Rod	Std Pkg
1/2" EMT	FS1 ★	FS1 ★	FS1 ★	100
1/2" RIGID	FS1 ★	FS2 ★	FS2 ★	100
3/4" EMT	FS2 ★	FS2 ★	FS2 ★	100
3/4" RIGID	FS2 ★	FS2 ★	FS3 ★	100
1" EMT	—	FS3 ★	FS3 ★	100
1" RIGID	—	—	—	100
1 1/4" EMT	—	FS4 ★	FS4 ★	100

### Static Load Limit

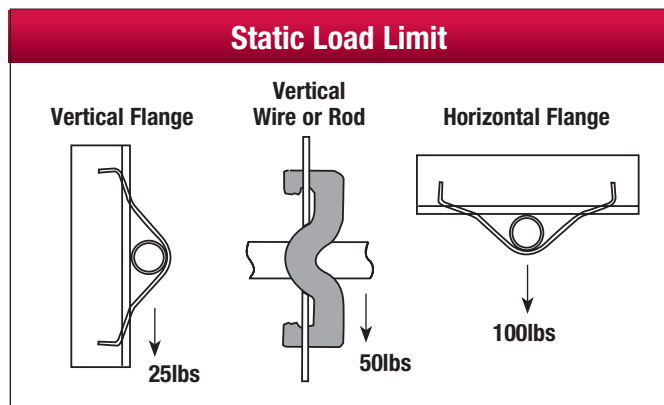

Conduit Size	1/8" to 1/4" Flange	5/16" to 3/8" Flange	7/16" to 1/2" Flange	Std Pkg
1/2" EMT	FS1 ★	FS2 ★	FS2 ★	100
1/2" RIGID	FS2 ★	FS2 ★	FS3 ★	100
3/4" EMT	FS2 ★	FS3 ★	FS3 ★	100
3/4" RIGID	FS3 ★	FS4* ★	FS4* ★	100
1" EMT	FS3 ★	FS4* ★	FS4* ★	100
1" RIGID	FS4* ★	FS4* ★	FS4* ★	100
1 1/4" EMT	FS4 ★	—	—	100

\*For horizontal applications only.

★ Made in USA



## MULTI-FUNCTION CLIP

- Attaches conduit or boxes to flanges, wire or rod.
- Attaches to #12 wire through 3/8" rod.
- Attaches #10-24 or 1/4"-20 threaded bridle rings (position only).

Description	Part #	Std Pkg
Fits 1/8" to 3/8" Flanges; #12 Wire through 3/8" Rod; #10-24 or 1/4"-20 Threaded Impressions	APS ★	100

★ Made in USA

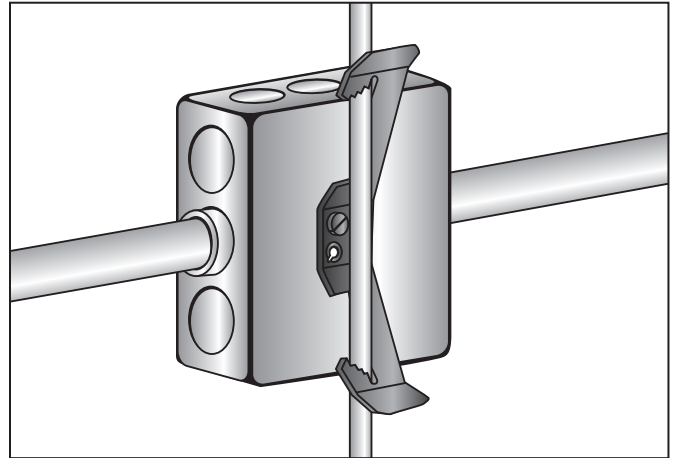

**Static Load Limit (Flange)**



## MULTI-FUNCTION CLIP ASSEMBLIES

- Attaches conduit or boxes to flanges, wire or rod.

Fits		Part #	Std Pkg
EMT	Rigid/IMC		
1/2	—	APS50 ★	100
3/4	1/2	APS75 ★	100
1	3/4	APS100 ★	100

Fits Conduit	Part #	Std Pkg
1/2 & 3/4	APSKC1234 ★	100
1	APSKC1 ★	100

★ Made in USA

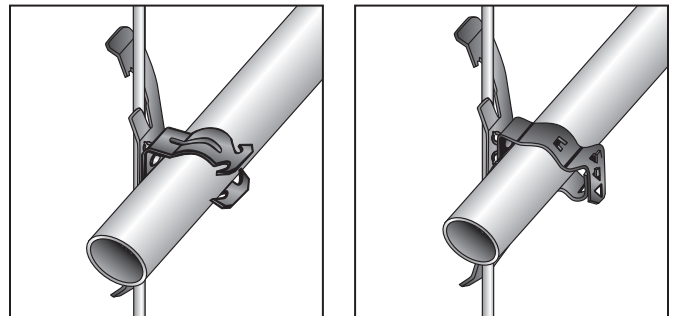

**Ultimate Static Load Limit (Flange)**

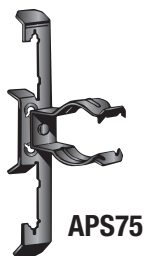

**Static Load Limit (Flange)**

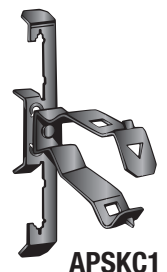

BLACK CLAW

## FLEXIBLE CONDUIT/CABLE CLIP

- Supports flexible conduit and all types of cable from flanges.
- Made from high-carbon steel and zinc plated.
- Some clips may require minimum order quantities. Please contact customer service.

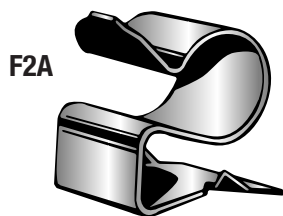
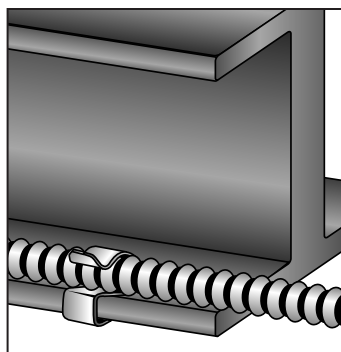

Description		Part #	Std Pkg
AC/MC Cable O.D.	Flange Size		
.218-.281	1/16-3/16	<b>F2A</b> ★	100
.312-.375	1/16-3/16	<b>F2B</b> ★	100
.375-.437	1/16-3/16	<b>F2C</b> ★	100
.468-.562	1/16-3/16	<b>F2D</b> ★	100
.562-.718	1/16-3/16	<b>F2E</b> ★	100
.750-.937	1/16-3/16	<b>F2F</b> ★	100
.968-1.250	1/16-3/16	<b>F2G</b> ★	100
.218-.281	3/16-9/32	<b>F4A</b> ★	100
.312-.375	3/16-9/32	<b>F4B</b> ★	100
.375-.437	3/16-9/32	<b>F4C</b> ★	100
.468-.562	3/16-9/32	<b>F4D</b> ★	100
.562-.718	3/16-9/32	<b>F4E</b> ★	100
.750-.937	3/16-9/32	<b>F4F</b> ★	100
.968-1.250	3/16-9/32	<b>F4G</b> ★	100
.218-.281	5/16-1/2	<b>F8A</b> ★	100
.312-.375	5/16-1/2	<b>F8B</b> ★	100
.375-.437	5/16-1/2	<b>F8C</b> ★	100
.468-.562	5/16-1/2	<b>F8D</b> ★	100
.562-.718	5/16-1/2	<b>F8E</b> ★	100
.750-.937	5/16-1/2	<b>F8F</b> ★	100
.968-1.250	5/16-1/2	<b>F8G</b> ★	100

★ Made in USA

## FLANGE MOUNT CONDUIT CLIP ASSEMBLY

### Ultimate Static Load Limit: 25lbs

- Suspends conduit from bottom of beam.
- Will pivot 360 degrees.
- Installs with hammer only.

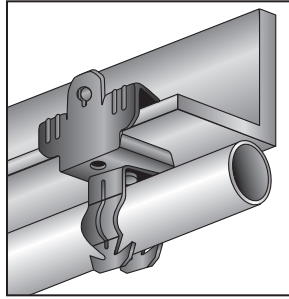

### Static Load Limit: 75lbs

- Suspends conduit from bottom of beam.
- Will pivot 360 degrees.
- Installs with hammer only.

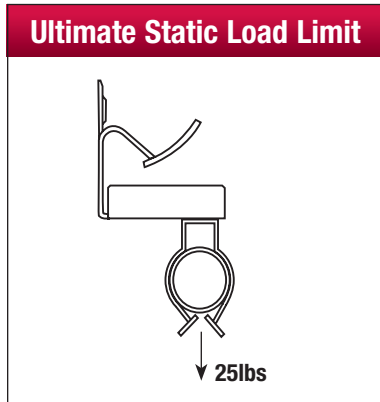
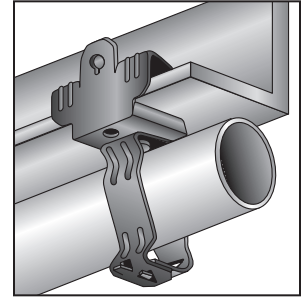

Bottom Mount



BC1875

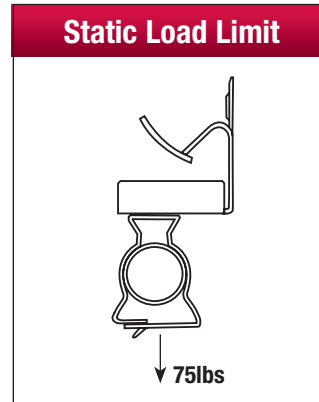

Static Load Limit

Bottom Mount

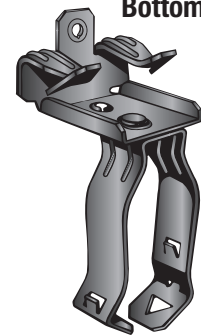

BC516KC1

Fits Flange	Fits EMT	Fits Rigid/IMC	Part #	Std Pkg
1/8-1/4	1/2	—	BC1850 ★	100
1/8-1/4	3/4	1/2	BC1875 ★	100
1/8-1/4	1	3/4	BC18100 ★	100
5/16-1/2	1/2	—	BC51650 ★	100
5/16-1/2	3/4	1/2	BC51675 ★	100
5/16-1/2	1	3/4	BC516100 ★	100

★ Made in USA

Fits Flange	Fits Conduit	Part #	Std Pkg
1/8-1/4	3/8	BC18KC38 ★	100
1/8-1/4	1/2 & 3/4	BC18KC1234 ★	100
1/8-1/4	1	BC18KC1 ★	100
1/8-1/4	1 1/4	BC18KC114 ★	100
1/8-1/4	1 1/2	BC18KC112 ★	100
1/8-1/4	2	BC18KC2 ★	100
5/16-1/2	3/8	BC516KC38 ★	100
5/16-1/2	1/2 & 3/4	BC516KC1234 ★	100
5/16-1/2	1	BC516KC1 ★	100
5/16-1/2	1 1/4	BC516KC114 ★	100
5/16-1/2	1 1/2	BC516KC112 ★	100
5/16-1/2	2	BC516KC2 ★	100
9/16-3/4	3/8	BC916KC38 ★	100
9/16-3/4	1/2 & 3/4	BC916KC1234 ★	100
9/16-3/4	1	BC916KC1 ★	100
9/16-3/4	1 1/4	BC916KC114 ★	100
9/16-3/4	1 1/2	BC916KC112 ★	100
9/16-3/4	2	BC916KC2 ★	100

★ Made in USA

## FLANGE MOUNT CONDUIT CLIP ASSEMBLY

### Ultimate Static Load Limit: 15lbs

- Suspends conduit from side of beam.
- Will pivot 360 degrees.
- Installs with hammer only.

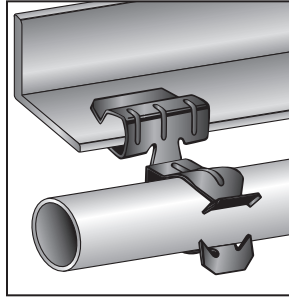

### Static Load Limit: 25lbs

- Suspends conduit from side of beam.
- Will pivot 360 degrees.
- Installs with hammer only.

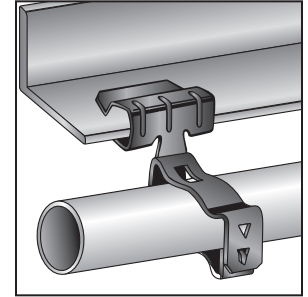

### Ultimate Static Load Limit

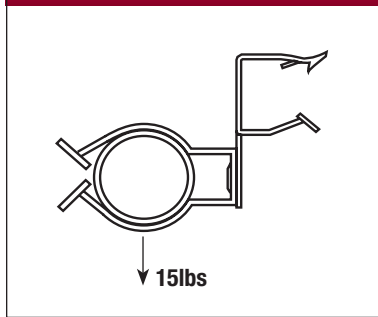

### Side Mount

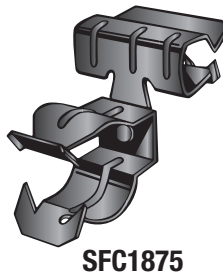

### Static Load Limit

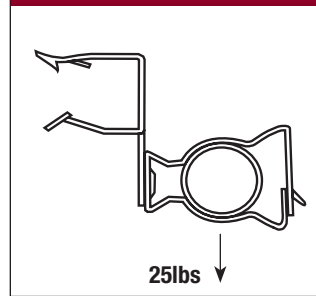

### Side Mount

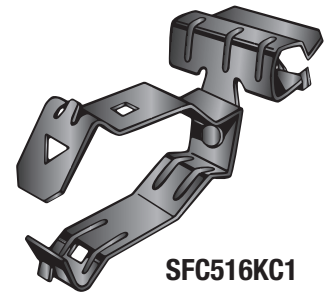

Fits Flange	Fits EMT	Fits Rigid/IMC	Part #	Std Pkg
1/8-1/4	1/2	—	SFC1850 ★	100
1/8-1/4	3/4	1/2	SFC1875 ★	100
1/8-1/4	1	3/4	SFC18100 ★	100

★ Made in USA

Fits Flange	Fits Conduit	Part #	Std Pkg
1/8-1/4	3/8	SFC18KC38 ★	100
1/8-1/4	1/2 & 3/4	SFC18KC1234 ★	100
1/8-1/4	1	SFC18KC1 ★	100
1/8-1/4	1 1/4	SFC18KC114 ★	100
1/8-1/4	1 1/2	SFC18KC112 ★	100
1/8-1/4	2	SFC18KC2 ★	100
5/16-1/2	3/8	SFC516KC38 ★	100
5/16-1/2	1/2 & 3/4	SFC516KC1234 ★	100
5/16-1/2	1	SFC516KC1 ★	100
5/16-1/2	1 1/4	SFC516KC114 ★	100
5/16-1/2	1 1/2	SFC516KC112 ★	100
5/16-1/2	2	SFC516KC2 ★	100
9/16-3/4	3/8	SFC916KC38 ★	100
9/16-3/4	1/2 & 3/4	SFC916KC1234 ★	100
9/16-3/4	1	SFC916KC1 ★	100

★ Made in USA

### ROD/WIRE • BRACKET SUPPORT

#### Angle Brackets

##### Static Load Limit: 160lbs

- Suspends #8 wire, 1/4" and 3/8" plain or threaded rod from overhead mountings with a clearance hole for 1/4" bolt.
- Hangers made from high-carbon steel, zinc phosphate and oil finish. Angle bracket made from pre-galvanized steel.

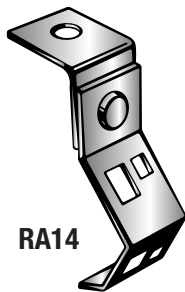
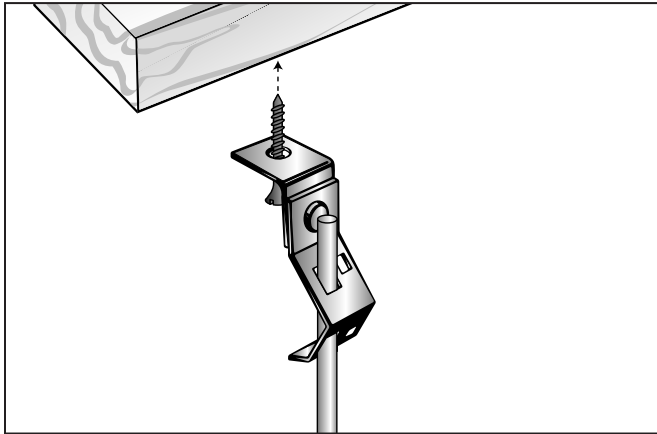

RA14

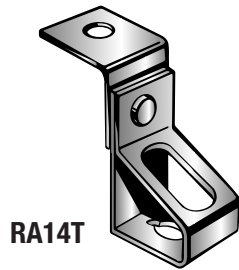

RA14T

#### Offset Brackets

##### Static Load Limit: 160lbs

- Suspends #8 wire, 1/4" and 3/8" plain or threaded rod from overhead mountings with a clearance hole for 1/4" bolt.
- Hangers made from high-carbon steel, zinc phosphate and oil finish. Offset bracket made from pre-galvanized steel.

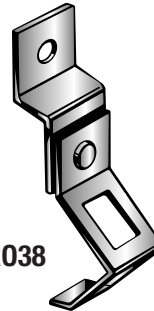
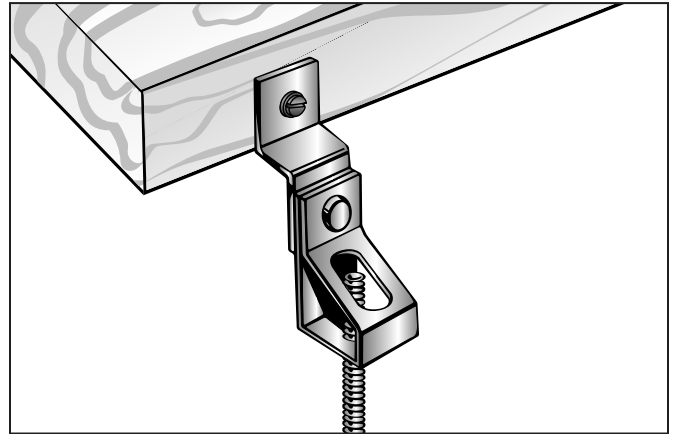

R038

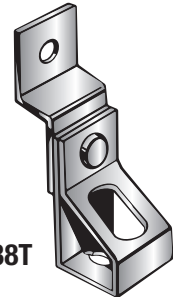

R038T

Angle Bracket Supports For Use With	Part #	Std Pkg
#8 Wire or 1/4" Plain Rod	RA14 ★	100
3/8" Plain Rod	RA38 ★	100
1/4" Threaded Rod with Thread Impression	RA14T ★	100
3/8" Threaded Rod with Thread Impression	RA38T ★	100
1/4" to 3/8" Threaded Rod*	RA1438N ★	100

\*Nut required

★ Made in USA

Angle Bracket Supports For Use With	Part #	Std Pkg
#8 Wire or 1/4" Plain Rod	R014 ★	100
3/8" Plain Rod	R038 ★	100
1/4" Threaded Rod with Thread Impression	R014T ★	100
3/8" Threaded Rod with Thread Impression	R038T ★	100
1/4" to 3/8" Threaded Rod*	R01438N ★	100

\*Nut required

★ Made in USA

## ROD/WIRE BEAM ASSEMBLIES

**Static Load Limit: 160lbs**

- Suspends #8 wire, 1/4" and 3/8" plain rod from overhead mountings.

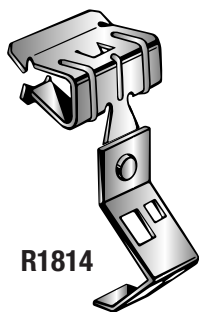
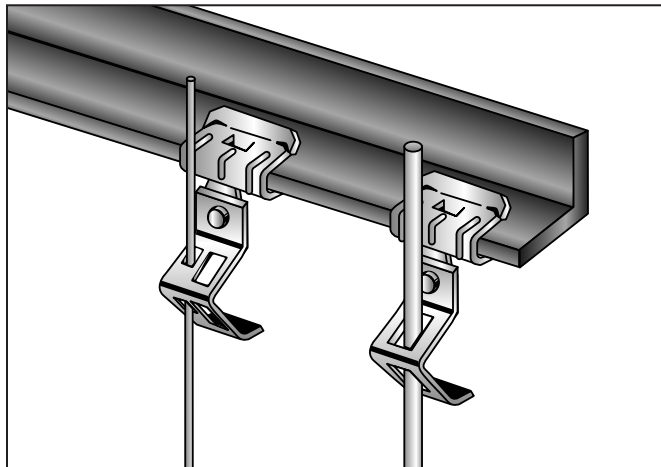

R1814

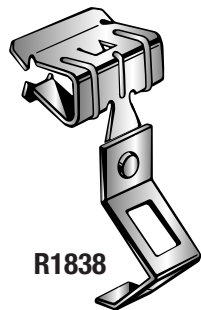

R1838

## THREADED ROD TO BEAM ASSEMBLIES

**Static Load Limit: 200lbs**

- Suspends 1/4" and 3/8" threaded rod from overhead mountings.

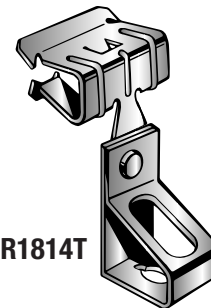
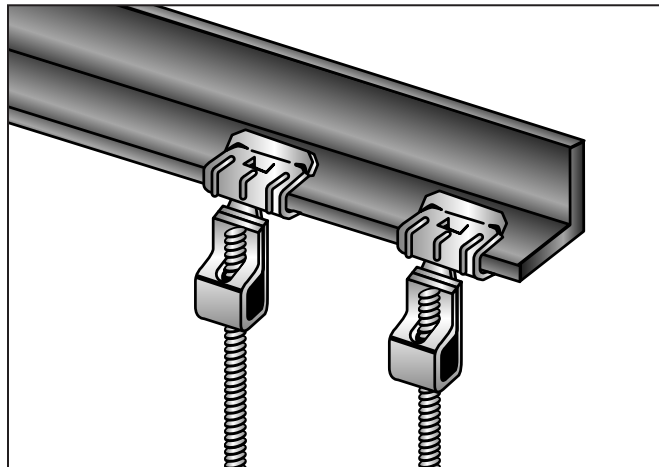

R1814T

BLACK CLAW

Flange Thickness	For Use With	Part #	Std Pkg
1/8-1/4	#8 Wire or 1/4" Plain Rod	<b>R1814</b> ★	100
5/16-1/2	#8 Wire or 1/4" Plain Rod	<b>R51614</b> ★	100
9/16-3/4	#8 Wire or 1/4" Plain Rod	<b>R91614</b> ★	100
1/8-1/4	3/8" Plain Rod	<b>R1838</b> ★	100
5/16-1/2	3/8" Plain Rod	<b>R51638</b> ★	100
9/16-3/4	3/8" Plain Rod	<b>R91638</b> ★	100

★ Made in USA

Flange Thickness	For Use With (Thread Impression)	Part #	Std Pkg
1/8-1/4	1/4" Threaded Rod	<b>R1814T</b> ★	100
5/16-1/2	1/4" Threaded Rod	<b>R51614T</b> ★	100
9/16-3/4	1/4" Threaded Rod	<b>R91614T</b> ★	100
1/8-1/4	3/8" Threaded Rod	<b>R1838T</b> ★	100
5/16-1/2	3/8" Threaded Rod	<b>R51638T</b> ★	100
9/16-3/4	3/8" Threaded Rod	<b>R91638T</b> ★	100

★ Made in USA

### STRAP HANGERS

#### Static Load Limit: 200lbs

- Suspends strapping thru 1" wide from beam flanges  $\frac{1}{8}$ " to  $\frac{3}{4}$ " thick, parallel or at right angles to beam.

Flange Thickness	Part #	Std Pkg
$\frac{1}{8}$ – $\frac{1}{4}$	PSF18 ★	100
$\frac{5}{16}$ – $\frac{1}{2}$	PSF516 ★	100
$\frac{9}{16}$ – $\frac{3}{4}$	PSF916 ★	100

Right Angle Strap Fits Flange Thickness	Part #	Std Pkg
$\frac{1}{8}$ – $\frac{1}{4}$	PSF18R ★	100
$\frac{5}{16}$ – $\frac{1}{2}$	PSF516R ★	100
$\frac{9}{16}$ – $\frac{3}{4}$	PSF916R ★	100

★ Made in USA

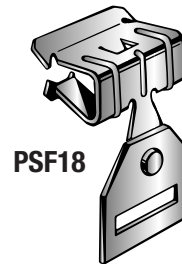
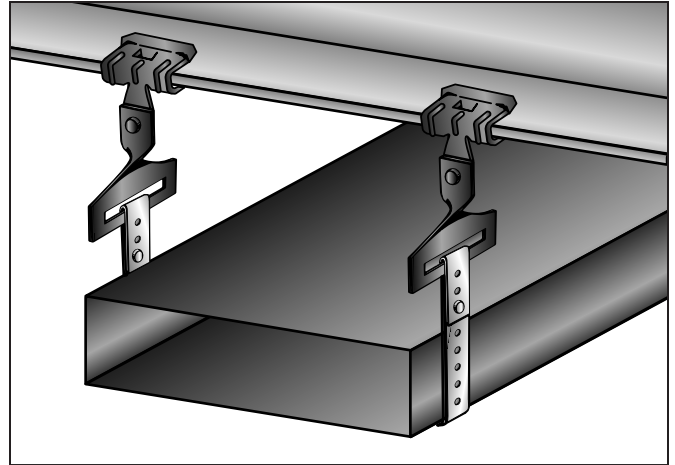

PSF18

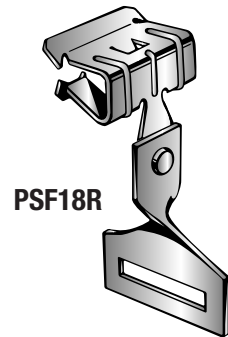

PSF18R

## BEAM CLAMPS

### Static Load Limit: 75lbs or 100lbs

- Can be used to suspend boxes, fixtures and bridle rings to beam flanges 1/8" to 3/4" thick.
- Beam Clamp with 1/4"-20 x 3/8" staked stud used to suspend box from bottom of beam.

**NOTE:** Static load limits cannot be combined.

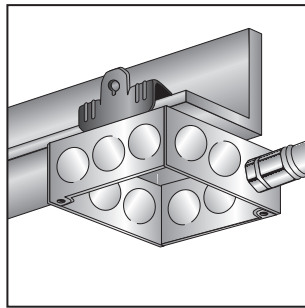
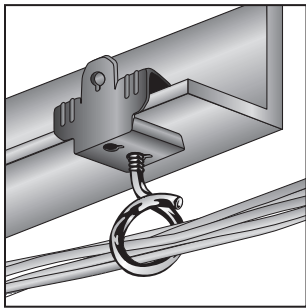

### Static Load Limit: 100lbs

- Fast installation; fits beam flange to 1/2".
- Used with 1/4" and 3/8" threaded rod, "S" hooks, conduit hangers, electrical boxes, and #10-24 or 1/4"-20 bridle rings.
- Tapping 1/4"-20 bottom and back. Also #10-24 tapping on back.

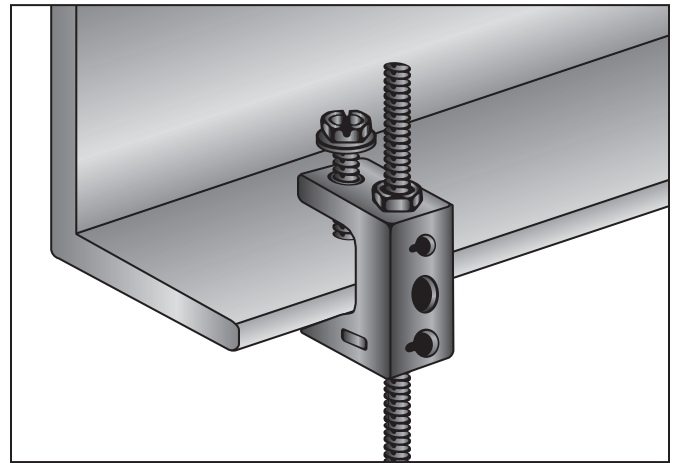

### Static Load Limit

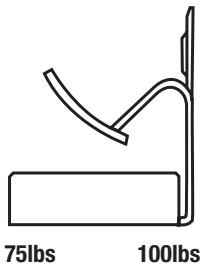

75lbs 100lbs



BC18



BC18ST

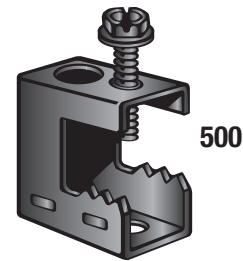

500

Flange Thickness	Part #	Std Pkg
<b>Bottom &amp; Back Tapped 1/4"-20</b>		
1/8-1/4	BC18 ★	100
5/16-1/2	BC516 ★	100
9/16-3/4	BC916 ★	100
<b>1/4"-20 x 3/8" Stud</b>		
1/8-1/4	BC18ST	100
5/16-1/2	BC516ST	100
9/16-3/4	BC916ST	100

★ Made in USA

Accommodates		Part #	Std Pkg
Flange	Drop Rod		
Up to 1/2" Thick	1/4-3/8	500	100



### BEAM CLAMP TO CONDUIT HANGER ASSEMBLIES

#### Ultimate Static Load Limit:

**25lbs Vertical Position**  
**15lbs Horizontal Position**

- Our #500 beam clamp with conduit hanger attached.

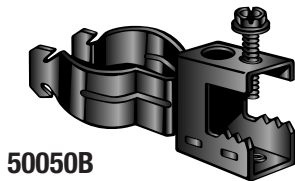
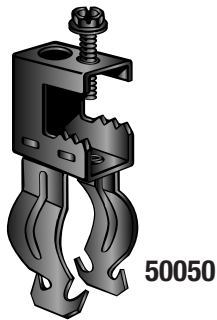
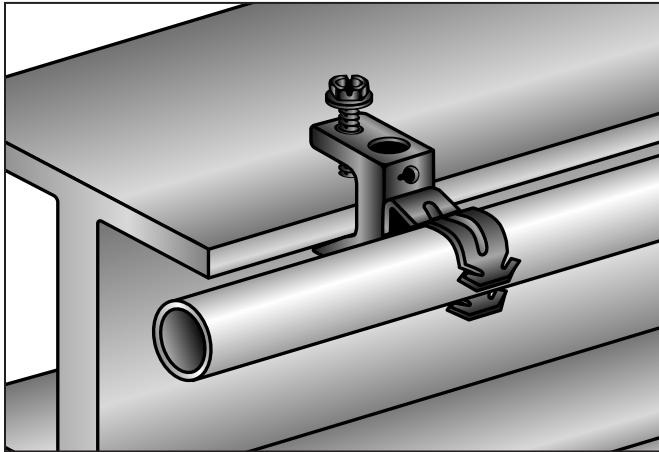

#### Static Load Limit:

**100lbs Vertical Position**  
**25lbs Horizontal Position**

- Part #500 beam clamp with conduit hanger attached.

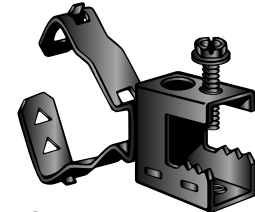
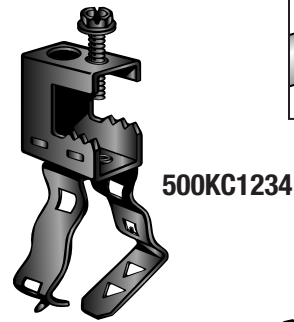
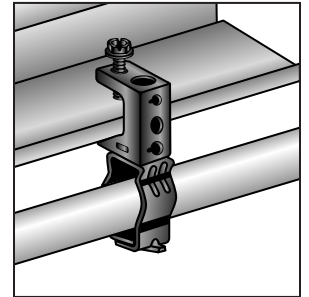

Fits EMT	Fits Rigid/IMC	Part #	Std Pkg
1/2	—	<b>50050</b>	100
3/4	1/2	<b>50075</b>	100
1	3/4	<b>500100</b>	100
1/2	—	<b>50050B</b>	100
3/4	1/2	<b>50075B</b>	100
1	3/4	<b>500100B</b>	100

Fits Conduit	Part #	Std Pkg
1/2 & 3/4	<b>500KC1234</b>	100
1	<b>500KC1</b>	100
1 1/4	<b>500KC114</b>	100
1 1/2	<b>500KC112</b>	100
2	<b>500KC2</b>	100
1/2 & 3/4	<b>500KC1234B</b>	100
1	<b>500KC1B</b>	100

### FLANGE BEAM CLAMP

#### Static Load Limit: 200lbs

- Installed with hammer on bulb tees and beams.
- Clearance for 1/4" bolt in tab.



SFC18

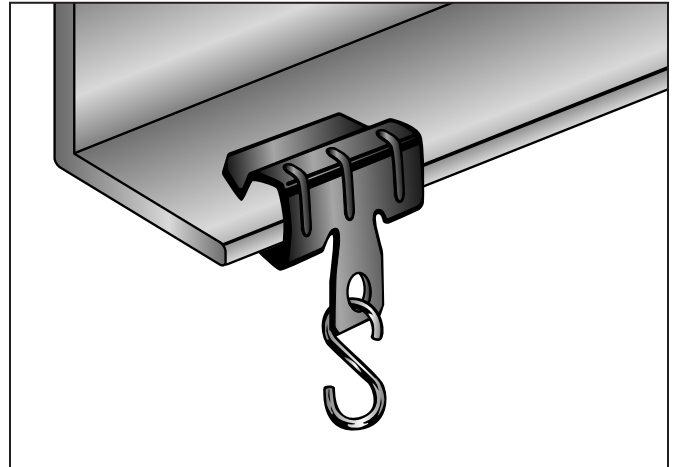

Flange Thickness	Part #	Std Pkg
1/8-1/4	SFC18 ★	100
5/16-1/2	SFC516 ★	100
9/16-3/4	SFC916 ★	100

★ Made in USA

### Z PURLIN HANGER

#### Static Load Limit: 100lbs

- Installed without power tools.
- Compensates for angle of purlin.

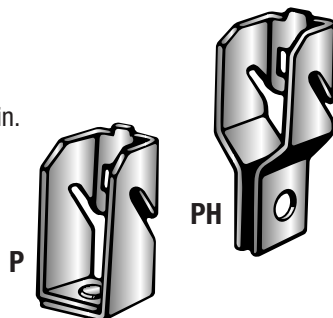

P

PH

Description	Part #	Std Pkg
1/4" Bottom Hole	P ★	100
1/4" Hole for Wire, S-hooks, Perforated Strap and Jack Chain	PH ★	100

★ Made in USA

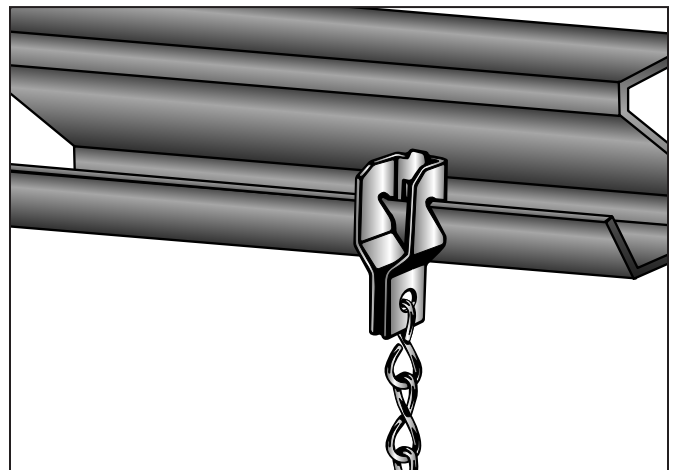

### Z PURLIN HANGER ASSEMBLIES

#### Static Load Limit: 100lbs

- Installed without power tools.
- Compensates for angle of purlin.

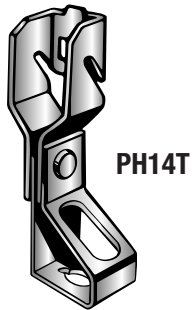
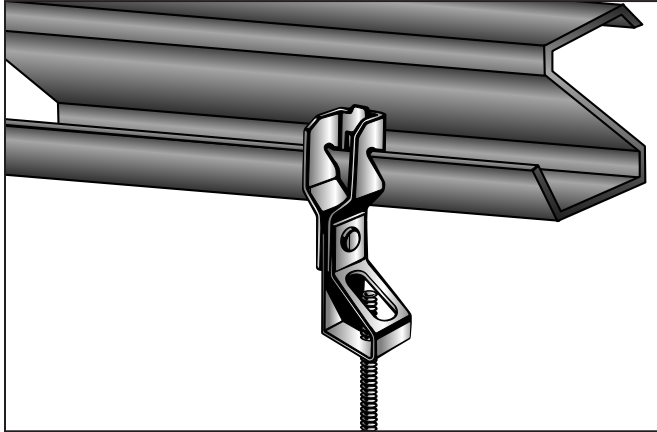

For Use With	Part #	Std Pkg
1/4" Threaded Rod	<b>PH14T</b> ★	100
3/8" Threaded Rod	<b>PH38T</b> ★	100
Up to 1" Strap	<b>PHPSR</b> ★	100

★ Made in USA

#### Ultimate Static Load Limit: 25lbs

- Installed without power tools.
- Compensates for angle of purlin.

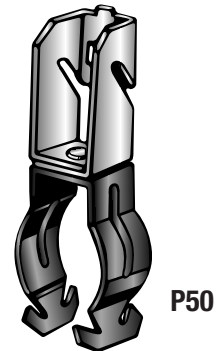
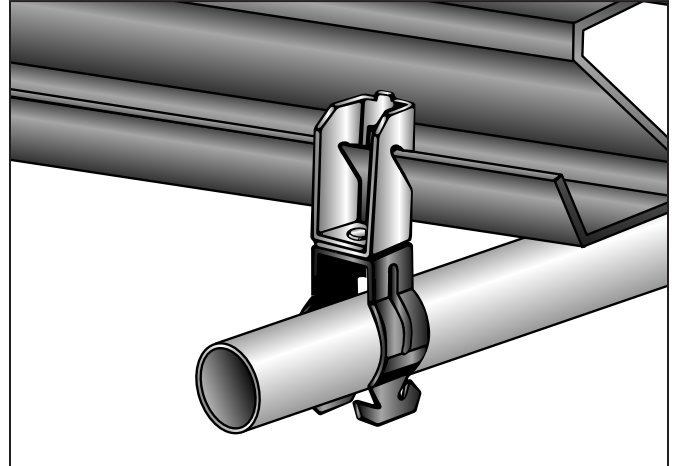

Description	Part #	Std Pkg
1/2" EMT	<b>P50</b> ★	100
1/2" EMT or 3/4" Rigid	<b>P75</b> ★	100
1" EMT or 3/4" Rigid	<b>P100</b> ★	50

★ Made in USA

## Z PURLIN HANGER ASSEMBLIES

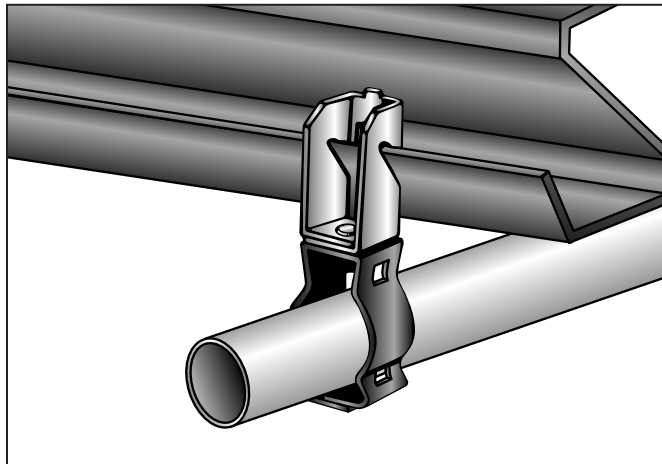

### Static Load Limit: 100lbs

- Installed without power tools.
- Compensates for angle of purlin.

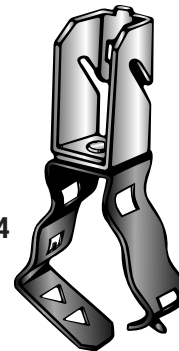

PKC1234

Description	Part #	Std Pkg
3/8" Conduit to Z Purlin	PKC38 ★	100
1/2" or 3/8" Conduit to Z Purlin	PKC1234 ★	100
1" Conduit to Z Purlin	PKC1 ★	100
1 1/4" Conduit to Z Purlin	PKC114 ★	50

★ Made in USA

## Z PURLIN FLANGE HANGER

BLACK CLAW

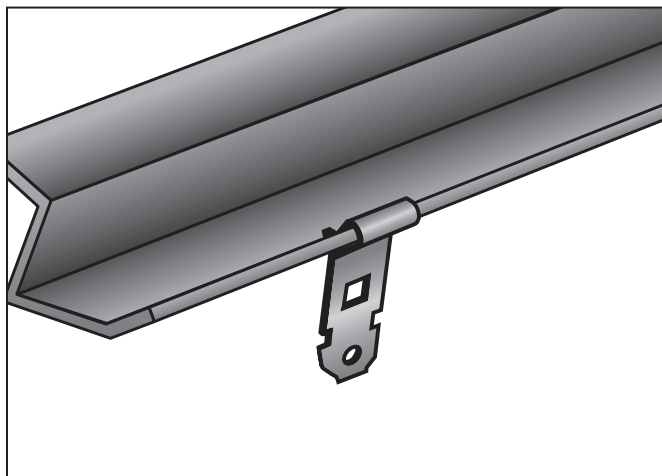

- Fits 1/6" to 1/4" thick Z Purlin (ABC25) or vertical flanges (VBC25).
- Clearance for 1/4" bolt.
- Accommodates tooling for floor installations.
- Assemblies available for ABC25 and VBC25. Please contact customer service.

Flange Thickness	For Use With	Part #	Std Pkg
1/6–1/4	Angled Z Purlin for S-Hooks, Perforated Strap and Wire	ABC25 ★	100
1/6–1/4	Vertical Flange for S-Hooks, Perforated Strap and Wire	VBC25 ★	100

★ Made in USA

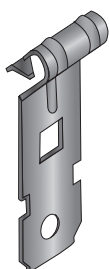

Static Load Limit: 100lbs  
ABC25

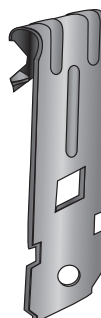

Static Load Limit: 160lbs  
VBC25

### FLANGE HANGER

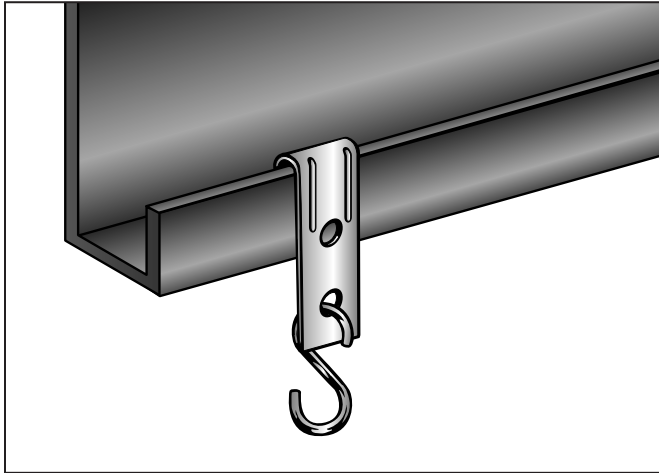

**Static Load Limit: 160lbs**

- Clearance for 1/4" bolt.

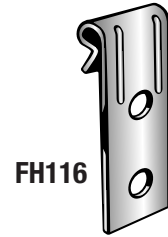

FH116

Flange Thickness	For Use With	Part #	Std Pkg
1/16–5/16	S-Hooks, Perforated Strap and Wire	FH116 ★	100
5/32–1/4	S-Hooks, Perforated Strap and Wire	FH532 ★	100

★ Made in USA

### ROD TO FLANGE HANGER

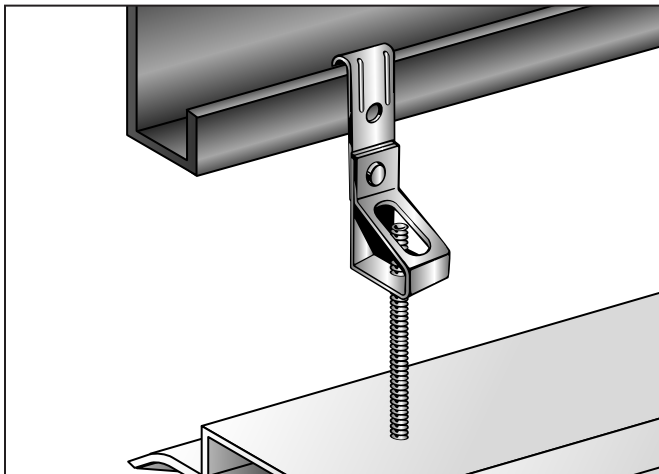

**Static Load Capacity: 160lbs**

- Suspends 1/4" or 3/8" threaded rod from vertical flange 1/16" to 1/4" thick.

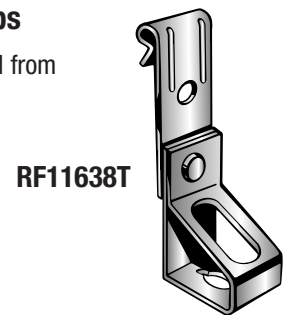

RF11638T

Flange Thickness	For Use With	Part #	Std Pkg
1/16–5/32	1/4" Threaded Rod	RF11614T ★	100
5/32–1/4	1/4" Threaded Rod	RF53214T ★	100
1/16–5/32	3/8" Threaded Rod	RF11638T ★	100
5/32–1/4	3/8" Threaded Rod	RF53238T ★	100

★ Made in USA

## CONDUIT/CABLE SUPPORT

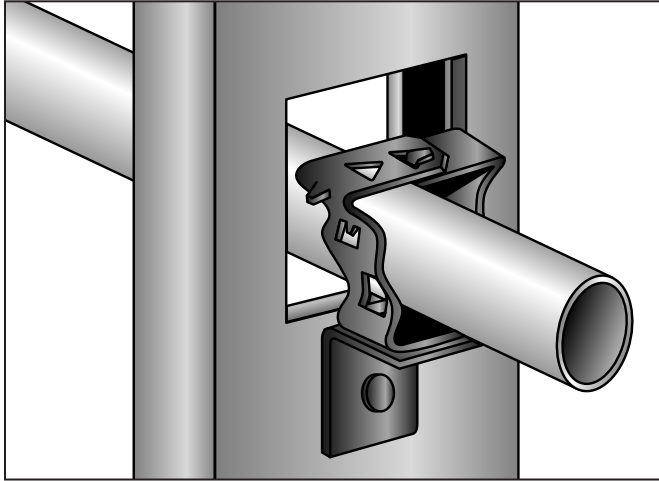

- Designed to secure horizontal runs of Rigid, EMT, AC, MC, BX or PVC through metal studs. 1/4" mounting hole on bracket.

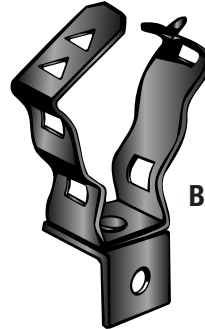

BAKC1234

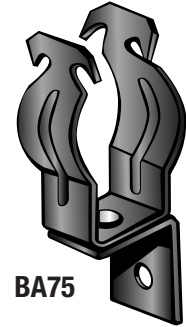

BA75

Fits Conduit	Part #	Std Pkg
3/8 or BX	<b>BAKC38</b> ★	100
1/2 or 3/4	<b>BAKC1234</b> ★	100
1/2 EMT	<b>BA50</b> ★	100
3/4 EMT or 1/2 Rigid	<b>BA75</b> ★	100

★ Made in USA

## FLEXIBLE CONDUIT/CABLE FASTENER

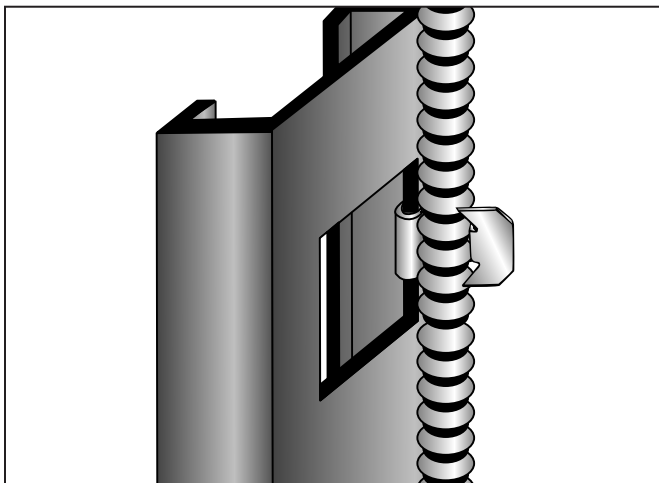

- Push clip attaches BX, MC or AC cable to metal studs.

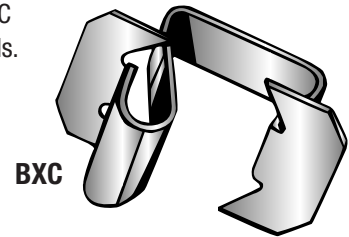

BXC

Description	Part #	Std Pkg
MC, AC or BX to Metal Stud	<b>BXC</b> ★	100

★ Made in USA

- Secures conduit to most metal studs.
- Installed using a hammer only.



SBX

Description	Part #	Std Pkg
MC or BX (12-2 thru 10-3) to Metal Studs	<b>SBX</b> ★	100

★ Made in USA

### CONDUIT TO STUD SUPPORT

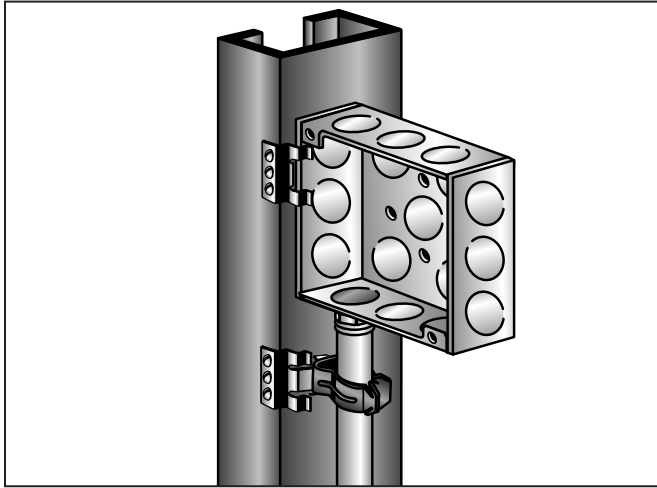

- Screw attached support for vertical runs of Rigid, EMT, or PVC to metal studs.
- See pages 223 and 253 for Far Side Box Support.

Fits EMT	Fits Rigid/IMC	Part #	Std Pkg
1/2	—	<b>SS50</b> ★	100
3/4	1/2	<b>SS75</b> ★	100
1	3/4	<b>SS100</b> ★	100

Fits Conduit	Part #	Std Pkg
1/2 or 3/4	<b>SSKC1234</b> ★	100
1	<b>SSKC1</b> ★	100

★ Made in USA

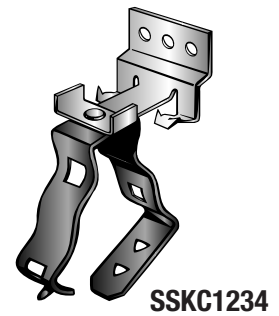
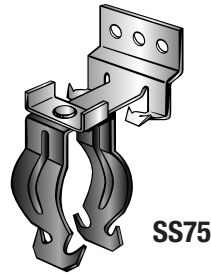

### BOX TO STUD FASTENER

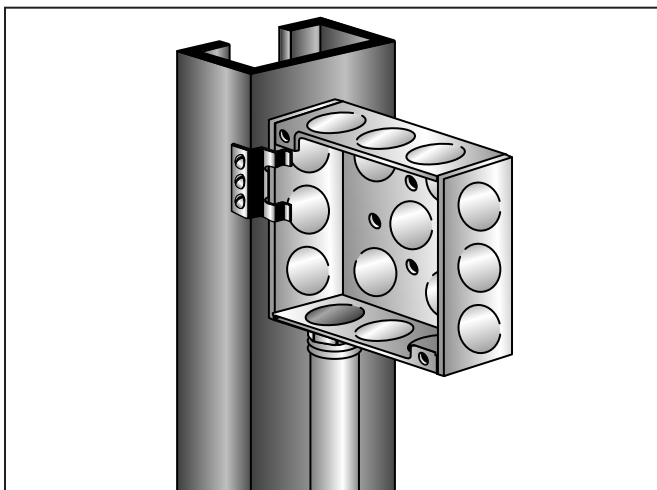

- Screw attached support for box and conduit. For use with either metal or wood studs.
- See pages 223 and 253 for Far Side Box Support.

Description	Part #	Std Pkg
Electrical Box Support Clip Secured with Self-Tapping Screws for Wood or Metal Studs	<b>SS</b> ★	100

★ Made in USA

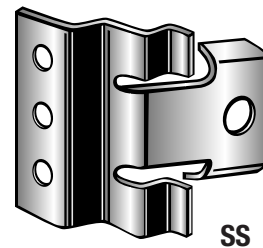

## BOX TO STUD SUPPORT

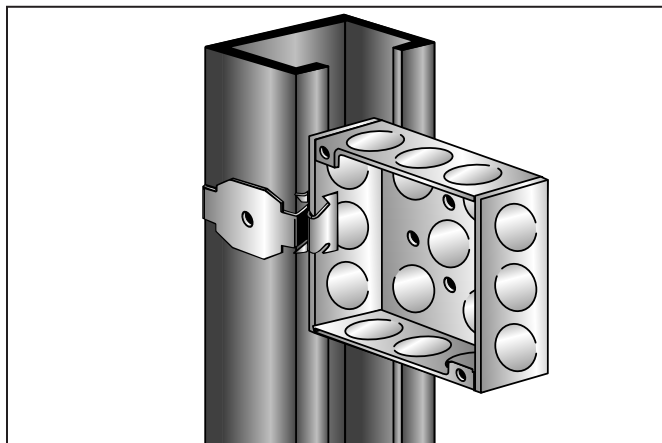

- Secures boxes to most metal studs.
- Installed using a hammer only.
- See pages 223 and 253 for Far Side Box Support.

Description	Part #	Std Pkg
Hammer Installed Electrical Box Support	<b>S1900</b> ★	100

★ Made in USA

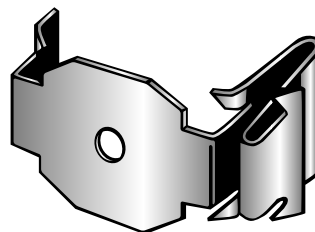

**S1900**

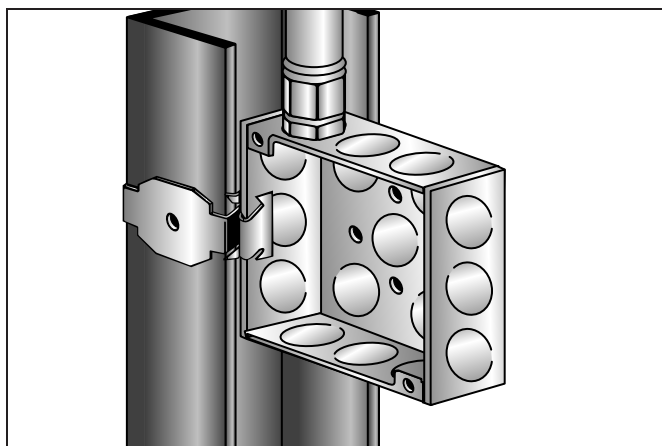

- Secures boxes to most metal studs.
- Series includes adjustable and preset versions.
- Installed using a hammer only.
- See pages 223 and 253 for Far Side Box Support.

Description	Part #	Std Pkg
Adjustable for 1/4" through 3/4" Drywall	<b>SBC</b> ★	100

★ Made in USA

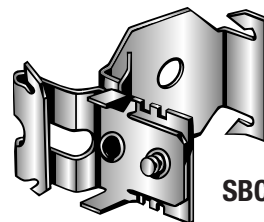

**SBC**

**BLACK CLAW**



### CONDUIT TO STUD FASTENER

- Designed to quickly secure vertical runs of Rigid, EMT, AC, MC, BX or PVC to metal studs.

Fits EMT	Fits Rigid/IMC	Part #	Std Pkg
1/2	—	<b>SB50</b> ★	100
3/4	1/2	<b>SB75</b> ★	100
1	3/4	<b>SB100</b> ★	100

Fits Conduit	Part #	Std Pkg
3/8 or BX	<b>SBKC38</b> ★	100
1/2 or 3/4	<b>SBKC1234</b> ★	100
1	<b>SBKC1</b> ★	100

★ Made in USA

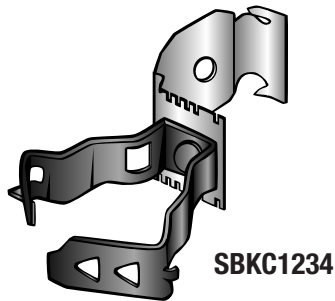
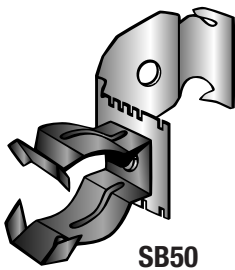
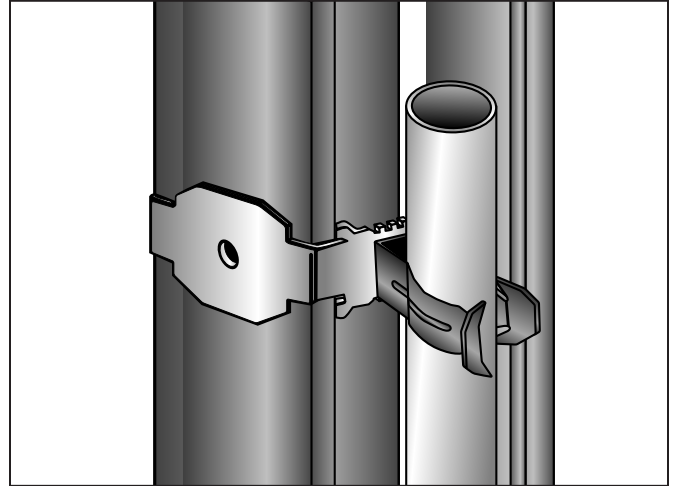

### FAR SIDE BOX SUPPORT

- Clips on electrical boxes for additional support.

Metal Stud Size	Part #	Std Pkg
2 1/2" thru 4", Sized by Bending at Premarked Lines	<b>SBS</b> ★	100
3 1/2	<b>SBS3.5</b> ★	100
6	<b>SBS6</b> ★	100

★ Made in USA

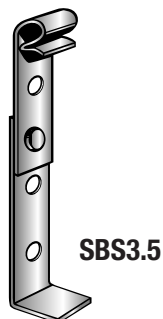
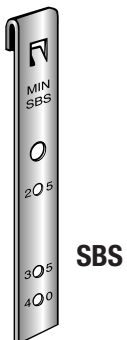
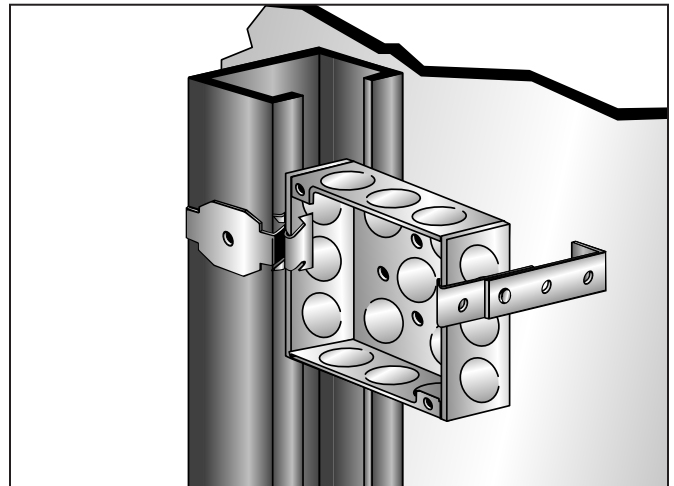

## LIGHTING • TROFFER FASTENER

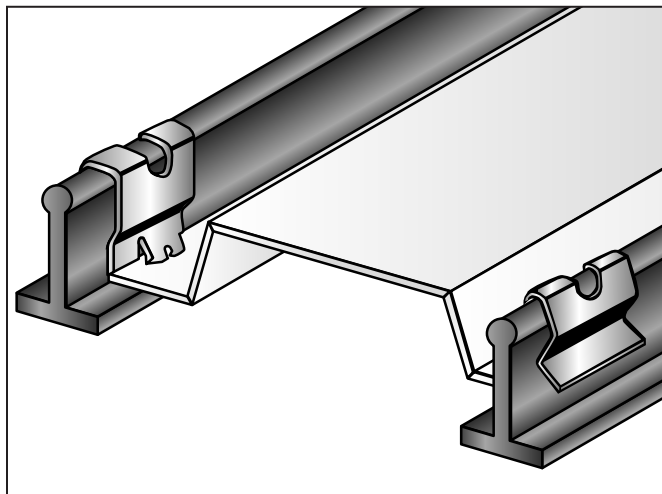

- Clip-on positive support for troffers and lay-in fixtures.
- Complies with 2011 NEC 410.36 (B) means of support.
- Fits round or rectangular head T-bars.

Description	Part #	Std Pkg
T-bar Clip for Troffers	FT ★	100

★ Made in USA

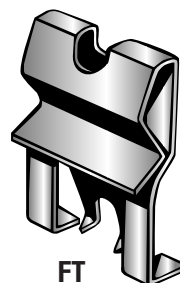

FT

## TWIST-ON T-BAR HANGER

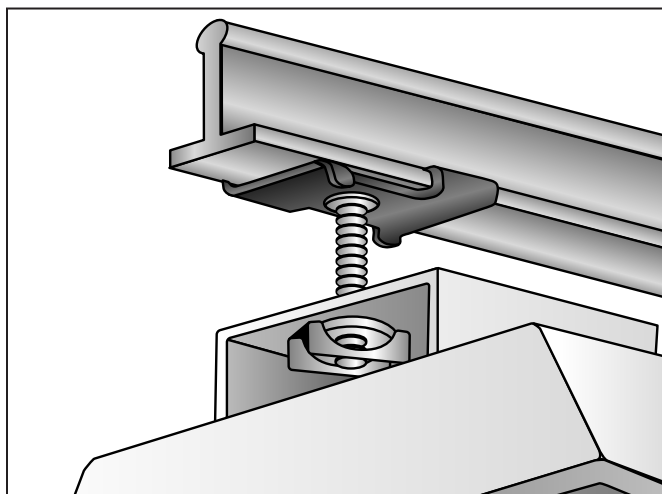

- Supports electrical fixtures to T-Bar 1 $\frac{1}{16}$ " wide.
- Assembled with 1" OD wing nut washer.
- 1/4"-20 stud 5/8" long.

Description	Part #	Std Pkg
Has 1/4"-20 x 5/8" Stud with Wing Nut Washer	SCT3	100

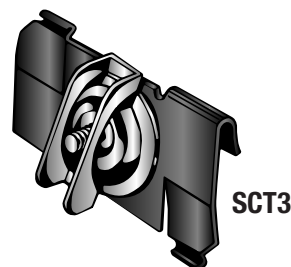

SCT3

### T-BAR FASTENERS

- Positive method of supporting conduit and outlet boxes above acoustical T-bar.

Description	Part #	Std Pkg
With ¼"-20 Thread Impression	<b>TBT</b> ★	100
With Plain Hole	<b>TB</b> ★	100

Description	Part #	Std Pkg
With ¼"-20 Thread Impression	<b>TST</b> ★	100
With Plain Hole	<b>TS</b> ★	100

★ Made in USA

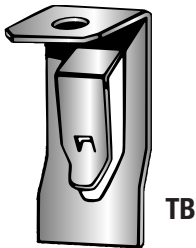
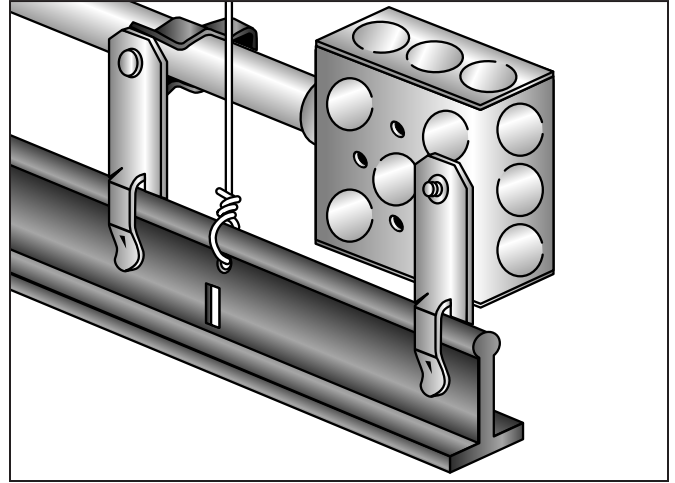

TB

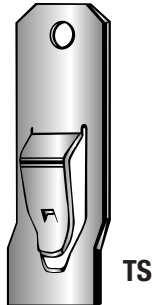

TS

## T-BAR FASTENERS

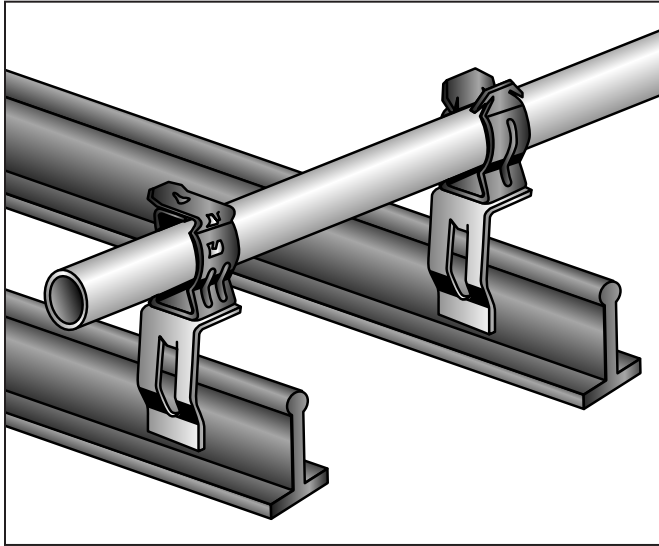

- Top mounted acoustical T-bar fastener. Riveted assembly fits 3/8" to 1" conduit.
- Supports boxes and conduit above T-bar.

Fits EMT	Fits Rigid/IMC	Part #	Std Pkg
1/2	—	<b>TB50</b> ★	100
3/4	1/2	<b>TB75</b> ★	100
1	3/4	<b>TB100</b> ★	100

Fits Conduit	Part #	Std Pkg
3/8 or BX	<b>TBKC38</b> ★	100
1/2, 3/4	<b>TBKC1234</b> ★	100
1	<b>TBKC1</b> ★	100

★ Made in USA



**TB50**

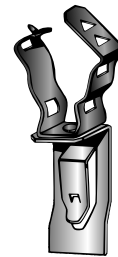

**TBKC1234**

BLACK CLAW

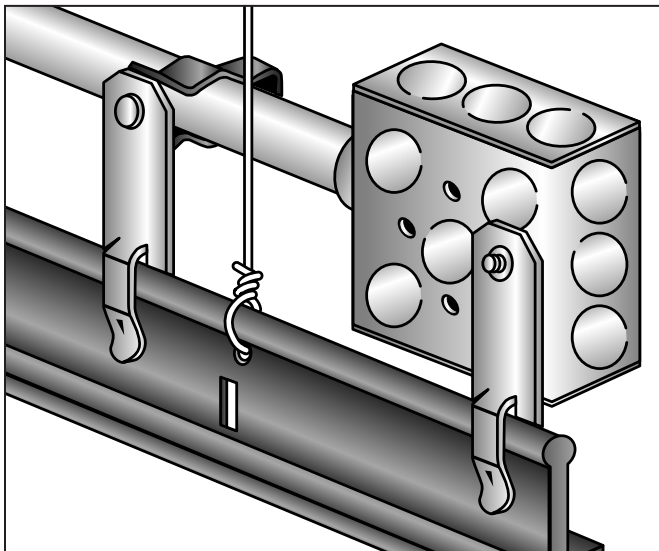

- Side mounted acoustical T-bar fastener. Riveted assembly fits 3/8" to 1" conduit.

Fits EMT	Fits Rigid/IMC	Part #	Std Pkg
1/2	—	<b>TS50</b> ★	100
3/4	1/2	<b>TS75</b> ★	100
1	3/4	<b>TS100</b> ★	100

Fits Conduit	Part #	Std Pkg
3/8 or BX	<b>TSKC38</b> ★	100
1/2, 3/4	<b>TSKC1234</b> ★	100
1	<b>TSKC1</b> ★	100

★ Made in USA

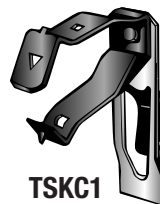

**TSKC1**



**TS50**

### PLASTIC CABLE TIE FASTENER

- For securing data/com cables.
- Supports cable ties up to 5/16" in width.
- Secures directly to wall.

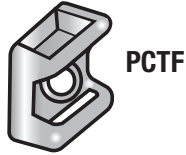

**PCTF**

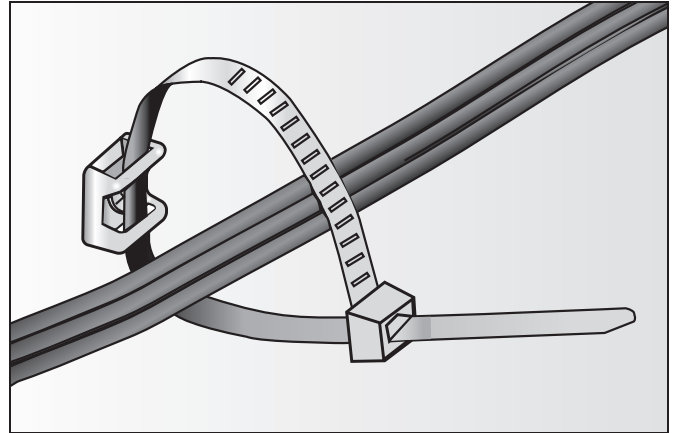

Description	Part #	Std Pkg
Screw Directly to Wall	<b>PCTF</b> ★	100

★ Made in USA

- For securing data/com cables to rod or flanges.
- Supports cable ties up to 5/16" in width.
- Plastic part made from quality UV stabilized and fire resistant material.

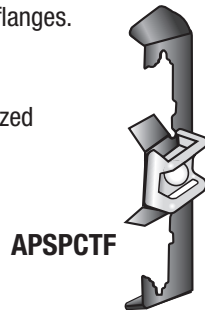

**APSPCTF**

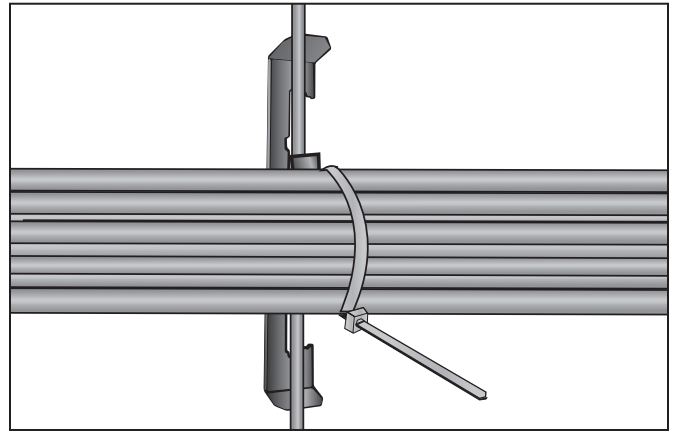

Description	Part #	Std Pkg
#12 Wire thru 1/4" Rod and 1/8" thru 3/8" Flange	<b>APSPCTF</b> ★	100

★ Made in USA

- For securing data/com cables to flanges.
- Supports cable ties up to 5/16" in width.
- Plastic part made from quality UV stabilized and fire resistant material.

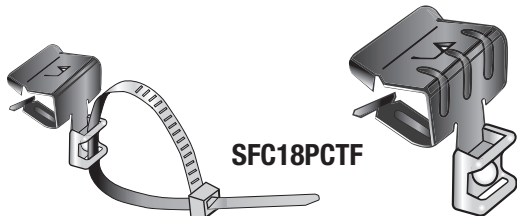

**SFC18PCTF**

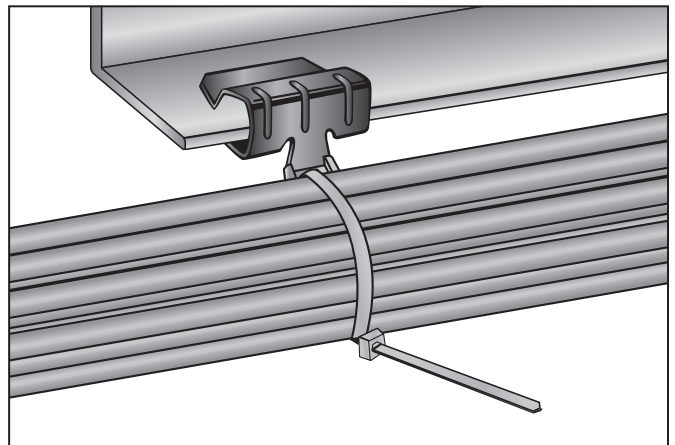

Description	Part #	Std Pkg
1/8" thru 1/4" Flange	<b>SFC18PCTF</b> ★	100
5/16" thru 1/2" Flange	<b>SFC516PCTF</b> ★	100

★ Made in USA

**BLACK CLAW**

### BOX TO BAR FASTENER

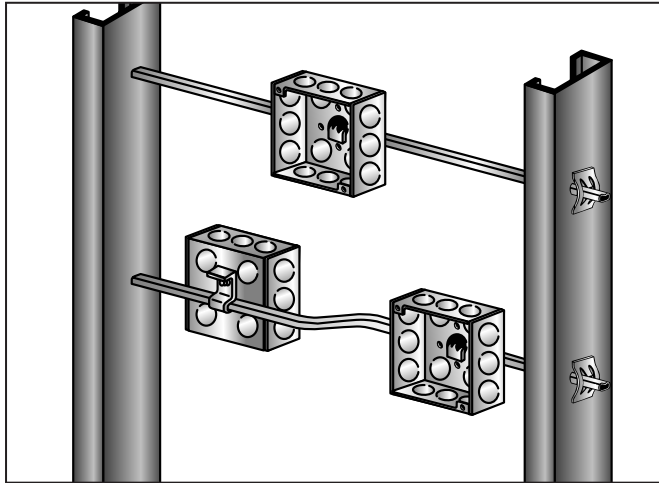

- Box to bar mounting clips.

Description	Part #	Std Pkg
Box Mounting Clip with Screw	<b>BBC</b> ★	100

★ Made in USA

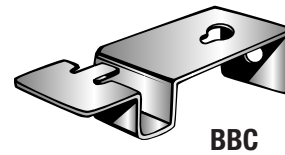

### ROD HANGERS

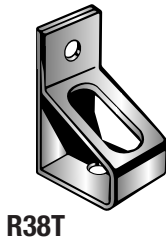

#### Static Load Capacity: 160lbs

- Used for hanging rod.

For Use With	Part #	Std Pkg
1/4" or 3/8" Threaded Rod*	<b>R1438N</b> ★	100
1/4" Threaded Rod with Threaded Impression	<b>R14T</b> ★	100
3/8" Threaded Rod with Threaded Impression	<b>R38T</b> ★	100

\*Nut required

★ Made in USA

# Compatibility & Size Reference Charts

## GALVANIC CORROSION COMPATIBILITY OF METALS

MATERIALS	Stainless Steel	Copper Plated Steel	Zinc Plated Steel	Aluminum	Spring Steel
Stainless Steel	Yes	No	Yes	Yes	Yes
Copper Plated Steel	No	Yes	No	No	No
Zinc Plated Steel	Yes	No	Yes	Yes	Yes
Aluminum	Yes	No	Yes	Yes	Yes
Spring Steel	Yes	No	Yes	Yes	Yes

## RIGID STEEL CONDUIT (Heavy Wall Conduit)

Nominal Conduit Size	Outside Diameter (inches)	Nominal Inside Diameter (inches)	Min. Weight (lbs) per 100 ft w/Couplings Attached	Weight (lbs) of Conduit & Conductor per 100 ft
3/8	0.675	0.493	51.5	65.1
1/2	0.840	0.632	79.0	101.1
3/4	1.050	0.836	105.0	145.8
1	1.315	1.063	153.0	219.3
1 1/4	1.660	1.394	201.0	318.3
1 1/2	1.900	1.624	249.0	408.8
2	2.375	2.083	332.0	593.8
2 1/2	2.875	2.489	527.0	901.0
3	3.500	3.090	682.6	1259.0
3 1/2	4.000	3.570	831.0	1604.0
4	4.500	4.050	972.3	1967.0

## RIGID ALUMINUM CONDUIT

- Dimensions taken from ANSI C80.3-1977.
- Conduit plus weight of heaviest conductor combination as specified by the National Electrical Code.

Nominal Conduit Size	Outside Diameter (inches)	Nominal Inside Diameter (inches)	Min. Weight (lbs) per 100 ft w/Couplings Attached	Weight (lbs) of Conduit & Conductor per 100 ft
1/2	0.840	0.632	27.4	49.5
3/4	1.050	0.836	36.4	84.3
1	1.315	1.063	53.0	130.3
1 1/4	1.660	1.394	69.6	212.3
1 1/2	1.900	1.624	82.2	269.8
2	2.375	2.083	115.7	401.8
2 1/2	2.875	2.489	182.5	579.0
3	3.500	3.090	238.9	626.3
3 1/2	4.000	3.570	287.7	1098.0
4	4.500	4.050	340.0	1364.0
5	5.563	5.073	465.4	2028.0
6	6.625	6.093	612.5	2870.0

## INTERMEDIATE METAL CONDUIT

Nominal Conduit Size	Outside Diameter (inches)	Nominal Inside Diameter (inches)	Min. Weight (lbs) per 100 ft w/Couplings Attached	Weight (lbs) of Conduit & Conductor per 100 ft
½	0.815	0.745	60.0	82.1
¾	1.029	0.954	82.0	122.8
1	1.290	1.205	116.0	182.3
1¼	1.638	1.553	150.0	267.3
1½	1.883	1.793	182.0	341.8
2	2.360	2.266	242.0	503.8
2½	2.857	2.727	401.0	775.0
3	3.476	3.346	493.0	1069.0
3½	3.971	3.841	573.0	1346.0
4	4.466	4.336	638.0	1632.0

## ELECTRICAL METALLIC TUBING (EMT) (Thin Wall Conduit)

- Dimensions taken from ANSI C80.3-1977.
- Conduit plus weight of heaviest conductor combination as specified by the National Electrical Code.

Nominal Conduit Size	Outside Diameter (inches)	Nominal Inside Diameter (inches)	Min. Weight (lbs) per 100 ft w/Couplings Attached	Weight (lbs) of Conduit & Conductor per 100 ft
¾	0.577	0.493	23.0	36.6
½	0.706	0.622	28.5	50.6
¾	0.922	0.824	43.5	84.3
1	1.163	1.049	64.0	130.3
1¼	1.510	1.380	95.0	212.3
1½	1.740	1.610	110.0	269.8
2	2.197	2.067	140.0	401.8
2½	2.875	2.731	205.0	579.0
3	3.500	3.356	250.0	626.3
3½	4.000	3.834	325.0	1098.0
4	4.500	4.334	370.0	1364.0

## SCHEDULE 40 PVC PLASTIC PIPE

Nominal Pipe Size	Outside Diameter (inches)	Wall Thickness (inches)	Weight of Pipe (lbs/ft)	Weight of Water (lbs/ft)
⅛	.405	.068	.04	.02
¼	.540	.088	.07	.04
⅜	.675	.091	.10	.08
½	.840	.109	.15	.1
¾	1.050	.113	.2	.2
1	1.315	.133	.3	.4
1¼	1.660	.140	.4	.6
1½	1.900	.145	.5	.9
2	2.375	.154	.6	1.4
2½	2.875	.203	1.0	2.1
3	3.500	.216	1.3	3.2
3½	4.000	.226	1.6	4.3
4	4.500	.237	1.9	5.5

## DIMENSION ALL THREAD ROD (ATR)

- Dimensions taken from ANSI B1.1-1982 Unified Inch Screw Threads.
- All threads are UNCR series.
- Tabulated loads are based on an allowable tensile stress of 12000 psi (82.7 MPa) reduced by 25% resulting in 9000 psi (62 MPa). From ANSI/MSS SP-58, Table 3.

Nominal Size & Thread	Root Area		Design Load (SF=5)	
	in. <sup>2</sup>	cm <sup>2</sup>	lbs	kN
¼ – 20	0.027	0.174	240	1.07
⅝ – 18	0.045	0.290	400	1.78
¾ – 16	0.068	0.438	610	2.71



## The Right Staple For The Job

The Impact Staples line offers residential insulated and non-insulated staples. Our most popular sizes of metal staples come with the standard dimple at the top—or try our “flat top” version. All plastic staples are made from high quality UV stabilization material for protection against harsh environments.

Minerallac Company's entire Impact Staples line is made in the U.S.A.

**262 Packaging Options**

**263 Non-Insulated Metal Staples**

**264 Insulated Metal Staples**

**265–266 Insulated Plastic Staples**



## PACKAGING OPTIONS

Impact™ staples are packaged in conveniently sized individual boxes. Our most popular styles of Impact™ staples are available in boxes, kraft bags, jars or bulk packed in kegs and reusable plastic pails.



## PLASTIC PAILS

Try Impact™ staples in our unique square-shaped pails. This weather-tight, sturdy, tip-resistant pail is easy to carry from job to job and has various other storage uses once the pail is empty.

## SQUARE JARS

New square jars with finger indent for pouring ease.



IMPACT STAPLES

## INSULATED PLASTIC IMPACT™ STAPLES

- Provide secure mounting without damage to wire and cable.
- Zinc plated nails are designed to minimize wood splitting.
- Pre-positioned nails ensure quick installation, even in vertical and overhead positions.
- Box, bag, jars or bulk packed.
- Available in reusable plastic pails.
- Staples are made from high impact UV stabilized material for severe weather conditions.

## NON-INSULATED & INSULATED METAL IMPACT™ STAPLES

- Leg design minimizes wood splitting.
- Staples are deburred and polished.
- Rust inhibitor applied for longer shelf life.
- Box, jars or bulk packed.
- Available in reusable plastic pails.
- Heavy-Duty 1" x 1/2" available to help eliminate "bending" when driven into hard wood.
- Flat Top" Version available for 1" x 1/2" and 1 1/4" x 9/16".
- Two types of insulated metal cable staples available for 1" x 1/2" and 1 1/4" x 9/16" sizes. PVC dipped and with Plastic Insulator, both in optic blue for high visibility.

## CABLE STAPLES

**Cable Size:** 2 Conductor (#12 & #14) Romex® and other type NM cable.

Style (L x W)	Part #	Pkg Qty (Pcs)	Shipper (Pcs)
Standard 1" x 1/2"	I10A ★	Box of 100	10,000
	I10C ★	Box of 500	10,000
	I10G ★	Jar of 500	3,000
	I10R ★	Pail of 5,000	5,000
Standard HEAVY DUTY 1" x 1/2"	I10HA ★	Box of 100	10,000
	I10HC ★	Box of 500	10,000
	I10HG ★	Jar of 500	3,000
	I10HR ★	Pail of 5,000	5,000
Flat Top HEAVY DUTY 1" x 1/2"	I10HFA ★	Box of 100	10,000
	I10HFC ★	Box of 500	10,000
	I10HFG ★	Jar of 500	3,000
	I10HFR ★	Pail of 5,000	5,000

**Cable Size:** S.E.U. 6/3 Cable

L x W	Part #	Pkg Qty (Pcs)	Shipper (Pcs)
1 5/16" x 3/4"	I13A ★	Box of 100	2,000

**Cable Size:** S.E.U. 2/3 Cable

L x W	Part #	Pkg Qty (Pcs)	Shipper (Pcs)
1 1/2" x 1"	I15A ★	Box of 100	2,000

★ Made in USA

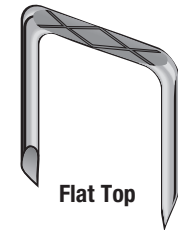
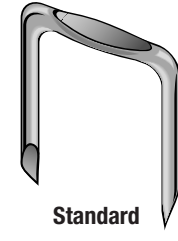
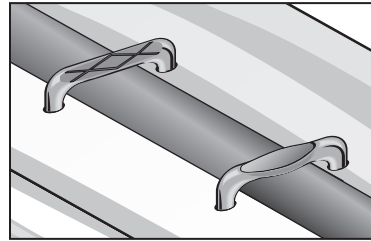

**Cable Size:** 3 Conductor (#10, #12 & #14) Romex®, BX, MC and other cable.

Style (L x W)	Part #	Pkg Qty (Pcs)	Shipper (Pcs)
Standard 1 1/4" x 5/16"	I12A ★	Box of 100	5,000
	I12C ★	Box of 500	5,000
	I12G ★	Jar of 500	3,000
	I12R ★	Pail of 5,000	5,000
	I12S ★	Pail of 7,500	7,500
Flat Top 1 1/4" x 5/16"	I12FA ★	Box of 100	5,000
	I12FC ★	Box of 500	5,000
	I12FG ★	Jar of 500	3,000
	I12FR ★	Pail of 5,000	5,000

## SERVICE ENTRANCE STAPLES

**Cable Size:** 6/3 S.E. 8-3 BX Range Cords

L x W	Part #	Pkg Qty (Pcs)	Shipper (Pcs)
1 3/8" x 1 3/16"	ISE13A ★	Box of 100	2,000

**Cable Size:** 4/3 S.E.R. 2/3 S.E. 3/4" EMT

L x W	Part #	Pkg Qty (Pcs)	Shipper (Pcs)
1 7/16" x 1 1/16"	ISE14A ★	Box of 100	2,000

**Cable Size:** 2/0 S.E., 1" EMT

L x W	Part #	Pkg Qty (Pcs)	Shipper (Pcs)
1 7/8" x 1 1/32"	ISE18U ★	Box of 50	1,000

★ Made in USA



**Cable Size:** 2/3 BX, 1" EMT, 1" Greenfield, 2/3 SER

L x W	Part #	Pkg Qty (Pcs)	Shipper (Pcs)
2 1/4" x 1 3/16"	ISE22U ★	Box of 50	1,000

**Cable Size:** 4/0 S.E. Greenfield, Large BX, Romex®, Tubing

L x W	Part #	Pkg Qty (Pcs)	Shipper (Pcs)
2 1/8" x 1 5/8"	ISE23U ★	Box of 50	1,000

## PLASTIC INSULATOR CABLE STAPLES

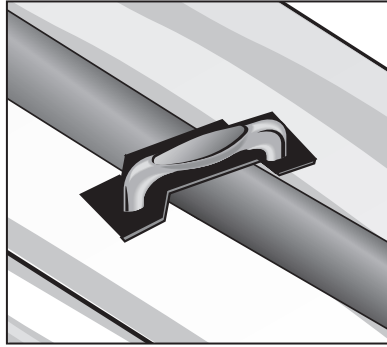
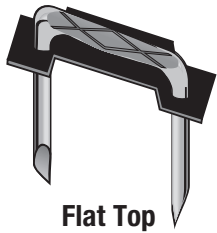

- Highly visible optic blue plastic insulator.
- Standard or flat top staple style.
- Packed in boxes and square plastic pails.

**Cable Size:** 2 Conductor (#12 & #14) Romex®, and other type NM cable.

Style and Size (L x W)	Part #	Pkg Qty (Pcs)	Shipper (Pcs)
Standard 1" x 1/2"	IPN1A ★	Box of 100	5,000
	IPN1C ★	Box of 500	5,000
	IPN1R ★	Pail of 5,000	5,000
Flat Top HEAVY DUTY 1" x 1/2"	IPN1HFA ★	Box of 100	5,000
	IPN1HFC ★	Box of 500	5,000

**Cable Size:** 3 Conductor (#10, #12 & #14) Romex®, BX, MC and other cable.

Style and Size (L x W)	Part #	Pkg Qty (Pcs)	Shipper (Pcs)
Standard 1 1/4" x 5/16"	IPN2A ★	Box of 100	5,000
	IPN2C ★	Box of 500	5,000
	IPN2R ★	Pail of 5,000	5,000
Flat Top 1 1/4" x 5/16"	IPN2FA ★	Box of 100	5,000
	IPN2FC ★	Box of 500	5,000
	IPN2FR ★	Pail of 5,000	5,000

★ Made in USA

## PVC DIPPED CABLE STAPLES

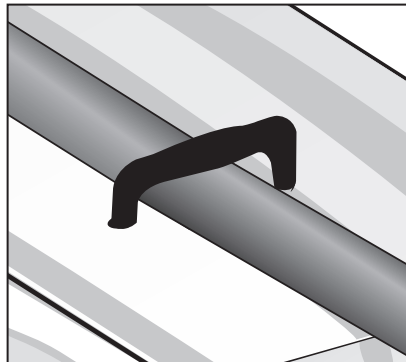

- Top of staple dipped in high impact hot melt PVC.
- Highly visible optic blue.
- Packed in boxes, jars and square plastic pails.

**Cable Size:** 2 Conductor (#12 & #14) Romex®, and other type NM cable.

Style and Size (L x W)	Part #	Pkg Qty (Pcs)	Shipper (Pcs)
HEAVY DUTY 1" x 1/2"	IPVC1HA ★	Box of 100	5,000
	IPVC1HC ★	Box of 500	5,000
	IPVC1HF ★	Jar of 350	2,100
	IPVC1HR ★	Pail of 5,000	5,000

**Cable Size:** 3 Conductor (#10, #12 & #14) Romex®, BX, MC and other cable.

Size (L x W)	Part #	Pkg Qty (Pcs)	Shipper (Pcs)
1 1/4" x 5/16"	IPVC2A ★	Box of 100	5,000
	IPVC2C ★	Box of 500	5,000
	IPVC2F ★	Jar of 350	2,100
	IPVC2R ★	Pail of 5,000	5,000

★ Made in USA

## PLASTIC CABLE STAPLES

**Cable Size:** 2 & 3-wire NM cable up to #12, 2-wire UF cable up to #12 and other cable up to 1/2" wide.

Color	Part #	Pkg Qty (Pcs)	Shipper (Pcs)
White	IPS50A ★	Box of 100	1,000
	IPS50C ★	Box of 500	2,500
	IPS50E ★	Jar of 200	1,200
	IPS50P ★	Pail of 2,000	2,000
	IPS50K ★	Kraft Bag of 500	2,500

**Cable Size:** 2-wire NM and UF cable up to #8, 3-wire UF cable up to #12 and other cable up to 3/4" wide.

Color	Part #	Pkg Qty (Pcs)	Shipper (Pcs)
White	IPS75A ★	Box of 100	1,000
	IPS75C ★	Box of 500	2,500
	IPS75D ★	Jar of 150	900
	IPS75P ★	Pail of 2,000	2,000
	IPS75L ★	Kraft Bag of 250	2,500

★ Made in USA

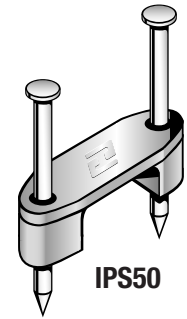
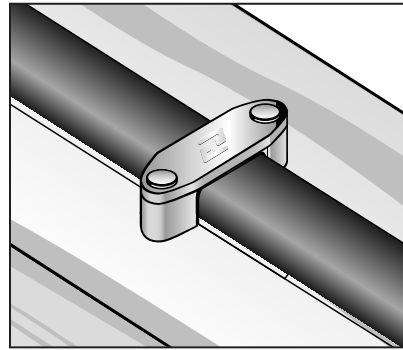

IPS50

- Our top selling insulated staples.
- For 1/2" and 3/4" wide single cables.
- UL Listed.
- Made from UV stabilized high impact plastic.

## STACKING CABLE STAPLES

**Cable Size:** For stacking two 2-wire #14 or #12 NM cable.

Color	Part #	Pkg Qty (Pcs)	Shipper (Pcs)
Tan	IPS502 ★	Box of 50	500

**Cable Size:** For stacking three 2-wire or a 2-wire and a 3-wire #4 and #12 NM cable.

Color	Part #	Pkg Qty (Pcs)	Shipper (Pcs)
Gray	IPS503 ★	Box of 50	500

**Cable Size:** For stacking two 3-wire or four 2-wire #14 or #12 NM cable.

Color	Part #	Pkg Qty (Pcs)	Shipper (Pcs)
White	IPS504 ★	Box of 50	500

★ Made in USA

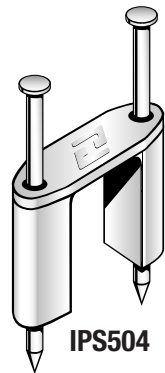
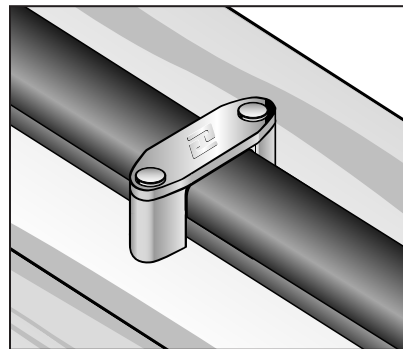

IPS504

- For stacking multiple 1/2" wide cables.
- Made from UV stabilized high impact plastic.

## SERVICE ENTRANCE STAPLES • STYLE SER



**ISER40**

- All staples are UV stabilized for severe weather conditions.
- Zinc plated nails made from high carbon steel for strength and durability.

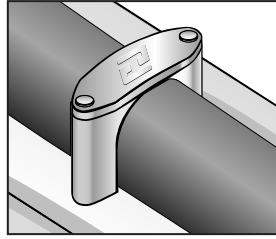

**Cable Size:** #6 Type SE, Style SER, 1/2" EMT (.718" Diameter)

Color	Part #	Pkg Qty (Pcs)	Shipper (Pcs)
Gray	<b>ISER10</b> ★	Box of 50	1,000

**Cable Size:** #2 Type SE, Style SER, 3/4" EMT (.937" Diameter)

Color	Part #	Pkg Qty (Pcs)	Shipper (Pcs)
Gray	<b>ISER20</b> ★	Box of 25	500

**Cable Size:** #2/0 Type SE, Style SER, 1" EMT (1.160" Diameter)

Color	Part #	Pkg Qty (Pcs)	Shipper (Pcs)
Gray	<b>ISER30</b> ★	Box of 25	500

**Cable Size:** #4/0 Type SE, Style SER, (1.438" Diameter)

Color	Part #	Pkg Qty (Pcs)	Shipper (Pcs)
Gray	<b>ISER40</b> ★	Box of 10	200

★ Made in USA

## BELL & THERMOSTAT STAPLES



**IBT251W**

- Available in black and white.
- All staples are UV stabilized for severe weather conditions.
- Zinc plated nails made from high carbon steel for strength and durability.

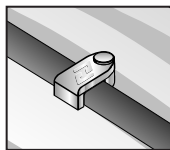

**Cable Size:** 1/4" 1-Nail

Color	Part #	Pkg Qty (Pcs)	Shipper (Pcs)
Black	<b>IBT251B</b> ★	Box of 100	1,000
White	<b>IBT251W</b> ★	Box of 100	1,000

★ Made in USA

## SERVICE ENTRANCE STAPLES • STYLE SEU

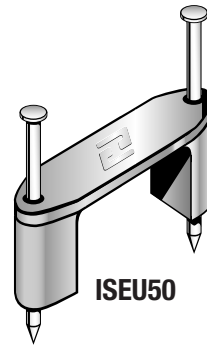

**ISEU50**

- All staples are UV stabilized for severe weather conditions.
- Zinc plated nails made from high carbon steel for strength and durability.

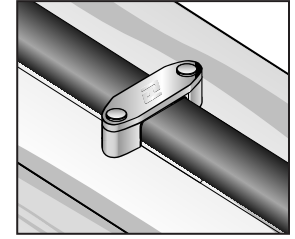

**Cable Size:** #6 Type SE, Style SEU, (.437" x .750")

Color	Part #	Pkg Qty (Pcs)	Shipper (Pcs)
Gray	<b>ISEU50</b> ★	Box of 50	1,000

**Cable Size:** #2 Type SE, Style SEU, (.550" x .972")

Color	Part #	Pkg Qty (Pcs)	Shipper (Pcs)
Gray	<b>ISEU60</b> ★	Box of 50	1,000

**Cable Size:** #2/0 Type SE, Style SEU, (.775" x 1.265")

Color	Part #	Pkg Qty (Pcs)	Shipper (Pcs)
Gray	<b>ISEU70</b> ★	Box of 25	500

**Cable Size:** #4/0 Type SE, Style SEU, (.855" x 1.500")

Color	Part #	Pkg Qty (Pcs)	Shipper (Pcs)
Gray	<b>ISEU80</b> ★	Box of 25	500

## NON-METALLIC SHEATHED CABLE STAPLES

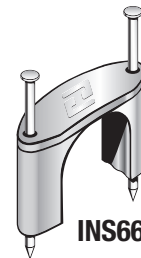

**INS66**

- All staples are UV stabilized for severe weather conditions.
- Zinc plated nails made from high carbon steel for strength and durability.

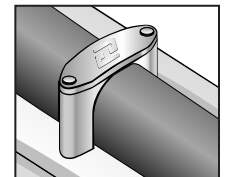

**Cable Size:** For 3-wire #8 and #6 NM cable and other cable up to 2 1/32" wide.

Color	Part #	Pkg Qty (Pcs)	Shipper (Pcs)
Gray	<b>INS66</b> ★	Box of 100	2,000

## Staples, Nails and Wire

Redmore offers popular sizes of utility staples with diamond or cut points in bright wire, mechanical galvanized or copperclad finishes.

Minerallac Company's entire Impact Staples line is made in the U.S.A.

**268** General Product Information

**269–273** Diamond Point Staples

**274–275** Cut Point Staples

**276–277** Nails

**278** Standard Gauge Wire Chart



## MANUFACTURING MATERIALS

**Bright Wire** – Bright Wire has no finish. Parts made from this material are recommended for applications where there is no issue with respect to corrosion as a result of exposure to harsh or outdoor environments.

**Pre-Galvanized** – Mill or Pre-Galvanized wire has a factory bonded zinc coating applied to a bright wire base. Parts made from this material are afforded a minimum zinc protection on uncut surfaces of .00015”.

**Copperclad** – Copperclad wire has a factory bonding of copper material to a bright wire base. This copperclad wire provides excellent corrosion protection for parts made from it and is preferred over coatings. The copper thickness is a minimum of 6% of the wire radius. This finish provides .0034” to .0073” thickness depending on the wire diameter.

## FINISHES

**Electro-Zinc Plated** – Bright wire parts are electro-zinc plated after forming. This plating provides a minimum zinc coating of .00015” applied to all surfaces.

**Mechanical Galvanized** – We coat our staples to Class 50, Type 1. Which is .002” of zinc and is 13 times greater in thickness than conventional electro-zinc coatings mechanical galvanized finish will withstand 300 hours to red rust in a 5% neutral salt spray test.

## MANUFACTURING OPTIONS

Additional sizes and styles of Redmore® products are available. Please contact customer service.

**Staples** – Redmore® Staples are produced with Diamond (rolled) points, Cut (slash points) or Flat (chisel) points. Contact sales for information and pricing on Flat Point Staples.

Most staples are produced with smooth wire, but our serrated diamond point or cut point staples are manufactured with grooves in the legs of the staples to increase holding power and reduce back-out problems.

**Nails** – We offer common nails in a variety of wire gauges in both hot-dipped galvanized and copperclad. We also offer roofing nails in two different sizes and a variety of pole marking nails including pole class, pole height, dating and delta inspection.

## PACKAGING OPTIONS

**Special Packaging/Label Options** – Redmore® is geared to customer service. Two available services include special packaging and custom labeling. Contact sales to discuss packaging options.

**Special Size Requirements** – We carry a large quantity of the most popular sizes. We also carry many sizes not shown in our catalog. If we do not carry the size you require, as a manufacturer, we have the capability to produce custom sizes if sufficient quantities are needed. Please contact sales to discuss specifications, production and plating minimums, set up charges and freight costs.

**Bulk Packaging** – All cut point staples are packed economically in bulk (loose staples packed in 50 lb. kegs.) Bright wire diamond point staples are also available packed in bulk.

### Wire Size

Wire Diameter	Part # Letter	Gauge	Inches
.114	C	—	—
.120	E	11	—
.144	I	—	—
.148	K	9	—
.162	Q	8	—
.187	S	6	3/16”
.250	W	—	—



### STAPLE MEASURING GUIDE

The following measurements correspond to those found at the top of the following pages:

**Dimension A (Overall Length)** – Measurement taken from top of staple to it's tip.

**Dimension B (Inside Spread)** – Measurement taken towards top of staple as indicated.

**Dimension C (Wire Diameter)** – Diameter of wire used in forming the staple. (See Wire Guide Reference on page 278.)

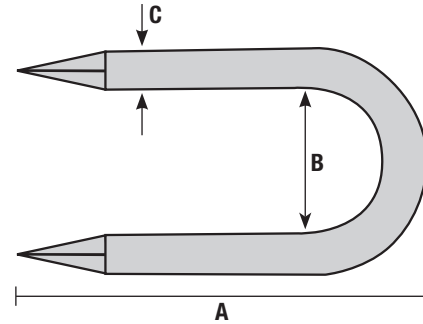

Diamond (Rolled) Point Staple

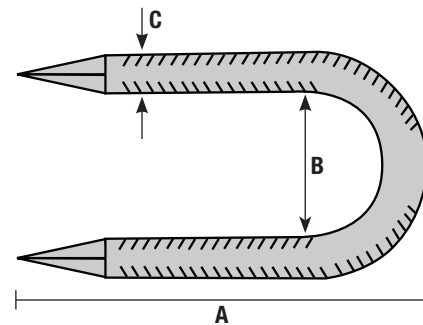

Serrated Diamond (Rolled) Point Staple

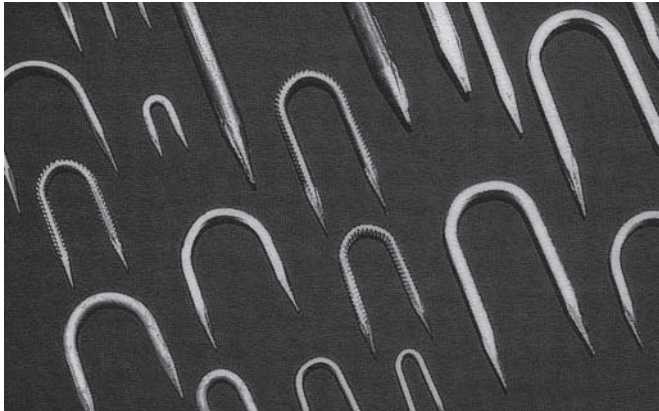

### SQUARE WIRE BARBED STAPLES • BOX PACK

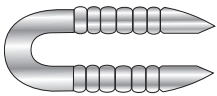

- Pounds per box is approximate and can vary + or – 10% depending on variances in wire weights and tolerances of staples during manufacture.

A	B	C				
Overall Length	Inside Spread	Wire Diameter	Part #	Pcs/Box	Boxes/ Carton	Approximate lbs/Box
<b>Mechanical Galvanized</b>						
1½	¾	.131	CG1538M(B) ★ ♡	350	5	5.0
2	¾	.131	CG2038M(B) ★ ♡	260	5	5.0
2	⅝	.165	CG2063T(B) ★ ♡	160	5	5.0
3	1⅙	.218	CG3090N(B)* ★ ♡	60	5	5.0
<b>Copperclad**</b>						
1½	¾	.140	CC1538P(B) ★	300	5	4.8

\*MOQ (Minimum Order Quantity)

\*\*Due to volatility of copper market, please contact customer service for pricing.

★ Made in USA

♡ Harsh Environment Product

For 50lb keg packaging, contact customer service for quantities and availability.

### BRIGHT WIRE DIAMOND POINT STAPLES • BOX PACK

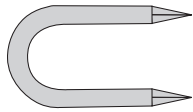

- Pounds per box is approximate and can vary + or – 10% depending on variances in wire weights and tolerances of staples during manufacture.

A	B	C				
Overall Length	Inside Spread	Wire Diameter	Part #	 Pcs/Box	Boxes/ Carton	Approximate lbs/Box
1½	¾	.148	<b>DB1538K</b> ★	100	10	1.28
1½	½	.148	<b>DB1550K</b> ★	100	10	1.30
1¾	¾	.148	<b>DB1738K</b> ★	100	10	1.58
1¾	⅝	.162	<b>DB1763Q</b> ★	100	10	1.92
2	½	.162	<b>DB2050Q</b> ★	100	10	2.13
2	⅝	.162	<b>DB2063Q</b> ★	100	10	2.22
2	⅝	.187	<b>DB2063S</b> ★	100	10	2.82
2	¾	.187	<b>DB2075S</b> ★	100	10	2.89
2½	¾	.187	<b>DB2575S</b> ★	100	10	3.64
2½	29/32	.187	<b>DB2588S</b> ★	100	10	3.77
2½	1¼	.187	<b>DB2592S</b> ★	100	10	3.90
3	¾	.187	<b>DB3075S</b> ★	100	5	4.50
3	1⅙	.250	<b>DB3090W</b> ★	100	5	7.52
3	1½	.250	<b>DB3095W</b> ★	100	5	7.84
3	1¾	.250	<b>DB3097W</b> ★	100	5	8.16
4	1¾	.250	<b>DB4097W*</b> ★	50	5	5.27

\*MOQ (Minimum Order Quantity)

★ Made in USA

For 50lb keg packaging, contact customer service for quantities and availability.

### BRIGHT WIRE DIAMOND POINT STAPLES • BULK PACK • 50LB KEG

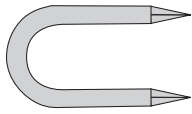

- Pounds per box is approximate and can vary + or – 10% depending on variances in wire weights and tolerances of staples during manufacture.

A	B	C	Part #	Approximate Pcs/50 lb Keg	Approximate Pcs/50lb Keg
Overall Length	Inside Spread	Wire Diameter			
1½	¾	.148	DB1538K-B50 ★	3900	78
1½	½	.148	DB1550K-B50 ★	3850	77
1¾	¾	.148	DB1738K-B50 ★	3250	65
1¾	⅝	.162	DB1763Q-B50 ★	2600	52
2	¾	.120	DB2038E-B50 ★	4150	83
2	½	.162	DB2050Q-B50 ★	2350	47
2	⅝	.162	DB2063Q-B50 ★	2250	45
2	⅝	.187	DB2063S-B50 ★	1750	35
2	¾	.187	DB2075S-B50 ★	1750	35
2½	¾	.187	DB2575S-B50 ★	1400	28
2½	29/32	.187	DB2588S-B50 ★	1350	27
2½	1¼	.187	DB2592S-B50 ★	1250	25
3	¾	.187	DB3075S-B50 ★	1100	22
3	1⅙	.250	DB3090W-B50 ★	650	13
3	1½	.250	DB3095W-B50 ★	650	13
3	1¾	.250	DB3097W-B50 ★	600	12
4	1¼	.250	DB4092W-B50* ★	500	10

\*MOQ (Minimum Order Quantity)

★ Made in USA

### ELECTRO-ZINC DIAMOND POINT STAPLES • BOX PACK

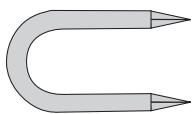

- Pounds per box is approximate and can vary + or – 10% depending on variances in wire weights and tolerances of staples during manufacture.

A	B	C	Part #	Pcs/Box	Boxes/ Carton	Approximate lbs/Box
Overall Length	Inside Spread	Wire Diameter				
1¾	¾	.148	DZ1738K ★	100	10	1.55
2	⅝	.162	DZ2063Q ★	100	10	2.18
2	⅝	.187	DZ2063S* ★	100	10	2.91
3	1⅙	.250	DZ3090W* ★	100	5	7.47

\*MOQ (Minimum Order Quantity)

★ Made in USA

### GALVANIZED DIAMOND POINT STAPLES • BOX PACK

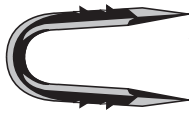
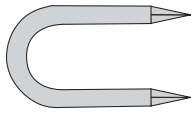

**\*\*Double Barbed  
DG3090W(H)**

• Pounds per box is approximate and can vary + or – 10% depending on variances in wire weights and tolerances of staples during manufacture.

A	B	C				
Overall Length	Inside Spread	Wire Diameter	Part #	 Pcs/Box	Boxes/ Carton	Approximate lbs/Box
1½	¾	.148	DG1538K ★ ▽	100	10	1.38
1½	¾	.120	DG1575E ★ ▽	100	10	1.00
2	½	.162	DG2050Q ★ ▽	100	10	2.22
2	⅝	.162	DG2063Q ★ ▽	100	10	2.25
2	1⅙	.187	DG2090S* ★ ▽	100	10	3.14
2½	29/32	.187	DG2588S ★ ▽	100	10	3.85
2½	1⅙	.187	DG2590S* ★ ▽	100	10	3.85
3	1⅙	.250	DG3090W ★ ▽	100	5	7.96
3	1⅙	.250	DG3090W(H)** ★ ▽	100	5	7.69
3	1¾	.250	DG3097W* ★ ▽	100	5	8.50
3½	1¾	.250	DG3597W* ★ ▽	50	5	4.76

\*MOQ (Minimum Order Quantity)

\*\*Double barbed

★ Made in USA

▽ Harsh Environment Product

### COPPERCLAD DIAMOND POINT STAPLES • BOX PACK

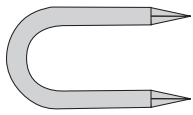

• Due to volatility of copper market, please contact customer service for pricing.

• Pounds per box is approximate and can vary + or – 10% depending on variances in wire weights and tolerances of staples during manufacture.

A	B	C				
Overall Length	Inside Spread	Wire Diameter	Part #	 Pcs/Box	Boxes/ Carton	Approximate lbs/Box
1	¼	.114	DC1025C ★	500	10	2.50
1¼	¼	.114	DC1225C ★	500	10	3.21
1½	⅝	.144	DC1531I ★	500	5	6.20
1¾	¾	.144	DC1738I ★	500	5	7.46
2	½	.162	DG2050Q ★	100	10	2.17
2	⅝	.162	DC2063Q ★	100	10	2.22
2	⅝	.187	DC2063S ★	100	10	2.89

★ Made in USA

For 50lb keg packaging, contact customer service for quantities and availability.

### DRIVE STOP® DIAMOND POINT STAPLES • BOX PACK

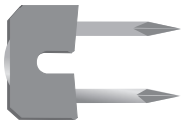

All Drive Stop® staples fitting #4 wire have a grey Drive Stop™.

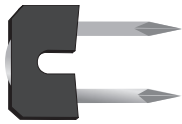

All Drive Stop® staples fitting #6 wire have a black Drive Stop™.

- Pounds per box is approximate and can vary + or – 10% depending on variances in wire weights and tolerances of staples during manufacture.

★ Made in USA  
 🛡️ Harsh Environment Product

A	B	C				
Overall Length	Inside Spread	Wire Diameter	Part #	Pcs/Box	Boxes/ Carton	Approximate lbs/Box
<b>For #4 AWG Ground Wire</b>						
2	5/8	.162	DG2063Q-#4 ★ 🛡️	100	5	3.20
<b>For #6 AWG Ground Wire</b>						
2	5/8	.162	DG2063Q-#6 ★ 🛡️	100	5	3.30

### SERRATED ELECTRO-ZINC DIAMOND POINT STAPLES • BOX PACK

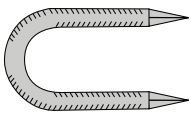

- Pounds per box is approximate and can vary + or – 10% depending on variances in wire weights and tolerances of staples during manufacture.

A	B	C				
Overall Length	Inside Spread	Wire Diameter	Part #	Pcs/Box	Boxes/ Carton	Approximate lbs/Box
1 3/4	3/8	.148	DZ1738K(S)* ★	100	10	1.57
2	5/8	.187	DZ2063S(S)* ★	100	10	2.81

\*MOQ (Minimum Order Quantity)

★ Made in USA

### ELECTRO-ZINC FLAT TOP DIAMOND POINT STAPLE

A	B	C				
Overall Length	Inside Spread	Wire Diameter	Part #	Pcs/Box	Boxes/ Carton	Approximate lbs/Box
2	5/8	.162	DZ2063Q(F) ★	100	10	2.24

★ Made in USA

### SERRATED GALVANIZED DIAMOND POINT STAPLES • BOX PACK

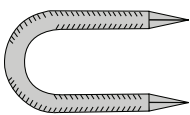

- Pounds per box is approximate and can vary + or – 10% depending on variances in wire weights and tolerances of staples during manufacture.

A	B	C				
Overall Length	Inside Spread	Wire Diameter	Part #	Pcs/Box	Boxes/ Carton	Approximate lbs/Box
1 3/4	3/8	.148	DG1738K(S) ★ 🛡️	100	10	1.57

★ Made in USA

🛡️ Harsh Environment Product

## STAPLE MEASURING GUIDE

The following measurements correspond to those found at the top of the following pages:

**Dimension A (Overall Length)** – Measurement taken from top of staple to its tip.

**Dimension B (Inside Spread)** – Measurement taken towards top of staple as indicated.

**Dimension C (Wire Diameter)** – Diameter of wire used in forming the staple. (See wire guide reference on page 278.)

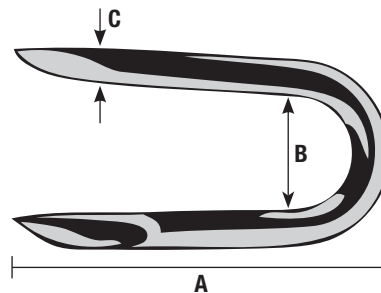
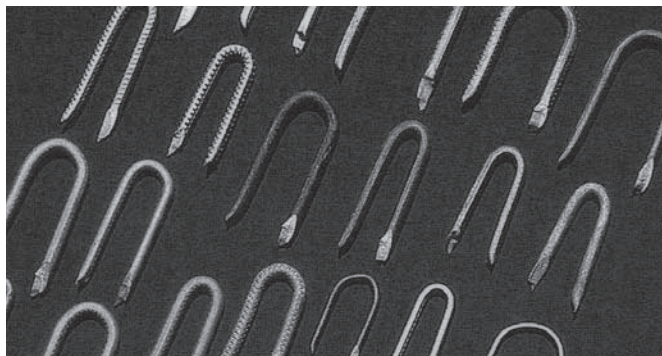

Cut (Slash) Point Staple

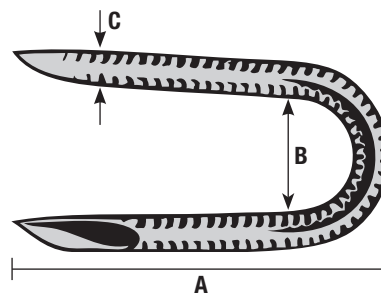

Serrated Cut (Slash) Point Staple

## PRE-GALVANIZED CUT POINT STAPLES • BULK PACK • 50LB KEG



- Pounds per box is approximate and can vary + or – 10% depending on variances in wire weights and tolerances of staples during manufacture.

REDMORE

A	B	C	Part #	Approximate Pcs/50 lb Keg	Approximate Pcs/lb
Overall Length	Inside Spread	Wire Diameter			
1¼	¼	.148	CP1225K ★	4675	94.00
1½	¼	.148	CP1525K ★	3750	75.00
1½	5/16	.148	CP1531K ★	3750	75.00
1½	½	.148	CP1550K ★	3750	75.00
1¾	¼	.148	CP1725K ★	3200	64.00
2	¼	.148	CP2025K* ★	2907	58.14
2¾	¾	.187	CP2775S* ★	1285	25.70

\*MOQ (Minimum Order Quantity)

★ Made in USA

For 5lb box packaging, contact customer service for quantities and availability.

### GALVANIZED CUT POINT STAPLES • BULK PACK • 50LB KEG



- Pounds per box is approximate and can vary + or – 10% depending on variances in wire weights and tolerances of staples during manufacture.

A	B	C	Part #	Approximate Pcs/50 lb Keg	Approximate Pcs/lb
Overall Length	Inside Spread	Wire Diameter			
1½	¼	.148	CG1525K ★ ▽	3500	70.00
1½	⅜	.148	CG1538K* ★ ▽	3600	72.00
1¾	⅜	.148	CG1738K* ★ ▽	3125	62.50
2	½	.162	CG2050Q ★ ▽	2235	44.70

\*MOQ (Minimum Order Quantity)

★ Made in USA

▽ Harsh Environment Product

### COPPERCLAD CUT POINT STAPLES • BULK PACK • 50LB KEG



- Due to volatility of copper market, please contact customer service for pricing.
- Pounds per box is approximate and can vary + or – 10% depending on variances in wire weights and tolerances of staples during manufacture.

A	B	C	Part #	Approximate Pcs/50 lb Keg	Approximate Pcs/lb
Overall Length	Inside Spread	Wire Diameter			
1½	⅜	.162	CC1538Q ★	3075	61.50
1¾	⅜	.144	CC1738I ★	3275	66.00
2	¼	.162	CC2025Q ★	2450	49.00
2	½	.162	CC2050Q ★	2275	46.00

★ Made in USA

## COMMON NAILS SIZE GUIDE

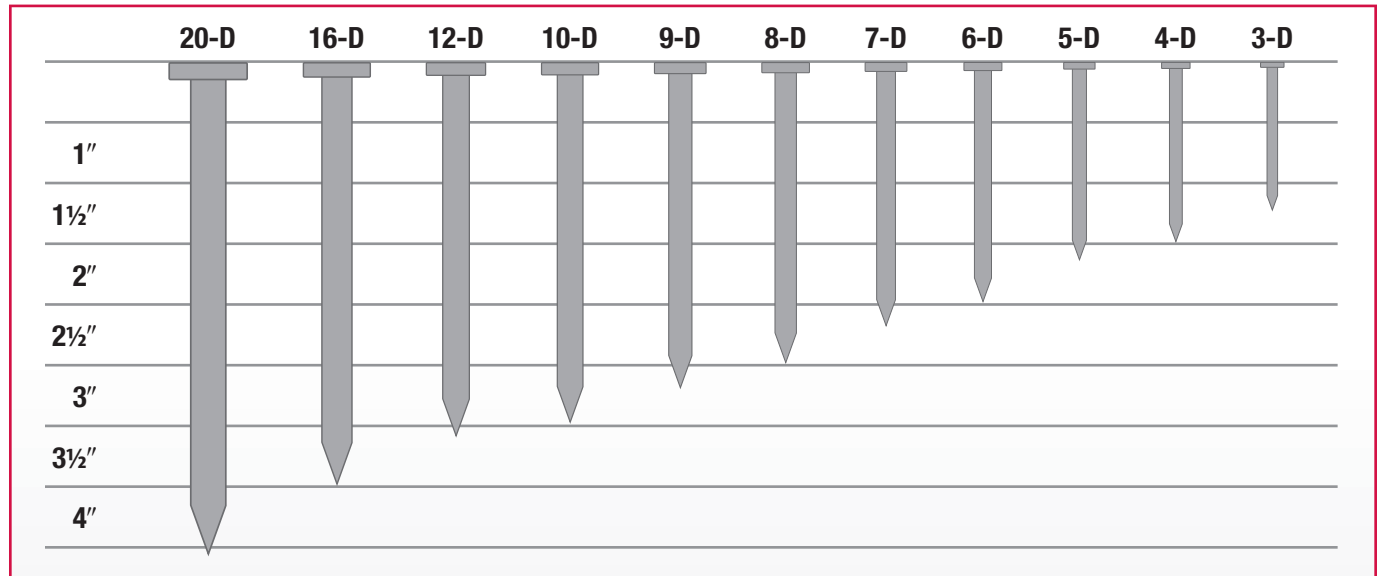

Note: Wire guide reference is on page 278.

## GALVANIZED ROOFING NAILS • BULK PACK • 50LB KEG

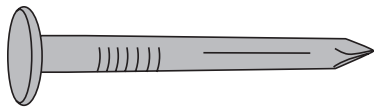

• Pounds per box is approximate and can vary + or – 10% depending on variances in wire weights and tolerances of staples during manufacture.

Size	Head	Part #	Approximate Pcs/50 lb Keg	Approximate Pcs/lb
1½ x 11 Gauge	¾"	NT11 ★ ♡	7600	152

★ Made in USA

♡ Harsh Environment Product

## GALVANIZED COMMON NAILS • BULK PACK • 50LB KEG



• Pounds per box is approximate and can vary + or – 10% depending on variances in wire weights and tolerances of staples during manufacture.

Size	Length (Inches)	Diameter (Inches)	Part #	Approximate Pcs/50 lb Keg	Approximate Pcs/lb
6-D	2	.114	NK06 ★ ♡	7450	149
16-D	3½	.162	NK16 ★ ♡	2300	46
20-D	4	.187	NK20 ★ ♡	1500	30

★ Made in USA

♡ Harsh Environment Product



### COPPERCLAD COMMON NAILS • BULK PACK • 50 LB KEG



- Pounds per box is approximate and can vary + or – 10% depending on variances in wire weights and tolerances of staples during manufacture.
- Due to volatility of copper market, please contact customer service for pricing.

Size	Length (Inches)	Diameter (Inches)	Part #	 Approximate Pcs/50 lb Keg	Approximate Pcs/lb
6-D	2	.114	<b>NC06*</b> ★	7500	150
10-D	3	.144	<b>NC10</b> ★	3450	69
16-D	3½	.162	<b>NC16</b> ★	2350	47

\*MOQ (Minimum Order Quantity)

★ Made in USA

### GALVANIZED MARKING NAILS

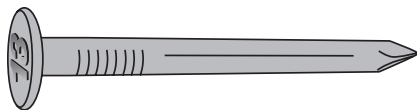

- All marking nails are 2½ x 6 gauge with ½" heads and weigh approximately 2.3 lbs per 100 pieces + or – 10% depending on variances in wire weights and tolerances of nails during manufacture.

Data & Blank Dating			
Description	Part #	 Pcs/Box	lbs/Box
2012 Dating	<b>ND212</b> ★ ♡	100	2.2
2013 Dating	<b>ND213</b> ★ ♡	100	2.2
Blank Dating	<b>ND1900</b> ★ ♡	100	2.2

★ Made in USA

♡ Harsh Environment Product

Data Dating		
Description	Part #	 Approximate Pcs/50 lb Keg
2012 Dating	<b>ND312</b> ★ ♡	2350
2013 Dating	<b>ND313</b> ★ ♡	2350

American Steel and Wire Gauge					
Actual Size of Wire	Gauge	Gauge	Diameter	lbs/ft	ft/lb
		000	.3625	.3505	2.853
		00	.3310	.2922	3.422
		0	.3065	.2506	3.991
		1	.2830	.2136	4.681
		2	.2625	.1838	5.441
		3	.2437	.1584	6.313
		4	.2253	.1354	7.386
		5	.2070	.1143	8.750
		6	.1920	.09832	10.17
		7	.1770	.08356	11.97
		8	.1620	.07000	14.29
		9	.1483	.05866	17.05
		10	.1350	.04861	20.57
		11	.1205	.03873	25.82
		12	.1055	.02969	33.69
		13	.0915	.02233	44.78
		14	.0800	.01707	58.58
		15	.0720	.01383	72.32
		16	.0625	.01042	95.98
		17	.0540	.007778	128.6
		18	.0475	.006018	166.2

Fraction	Decimal
1/64	.015625
1/32	.03125
3/64	.046875
1/16	.0625
5/64	.078125
3/32	.09375
7/64	.109375
1/8	.125
9/64	.140625
5/32	.15625
11/64	.171875
3/16	.1875
13/64	.203125
7/32	.21875
15/64	.234375
1/4	.25
17/64	.265625
9/32	.28125
19/64	.296875
5/16	.3125
21/64	.328125
11/32	.34375
23/64	.359375
3/8	.375
25/64	.390625
13/32	.40625
27/64	.421875
7/16	.4375
29/64	.453125
15/32	.46875
31/64	.484375
1/2	.5
33/64	.515625
17/32	.53125
35/64	.546875
9/16	.5625
37/64	.578125
19/32	.59375
39/64	.609375
5/8	.625
41/64	.640625
21/32	.65625
43/64	.671875
11/16	.6875
45/64	.703125
23/32	.71875
47/64	.734375
3/4	.75
49/64	.765625
25/32	.78125
31/64	.796875
13/16	.8125
53/64	.828125
27/32	.84375
55/64	.859375
7/8	.875
57/64	.890625
29/32	.90625
59/64	.921875
15/16	.9375
61/64	.953125
31/32	.96875
63/64	.984375
1	1

The Wire Gauge Chart shown above is used as a standard by practically all the steel manufacturers in the United States, on recommendation of the Bureau of Standards at Washington, D.C.

**Gauges such as Brown & Sharpe and screw gauges do not apply.**

REDMORE



## PRODUCT DISPLAYS

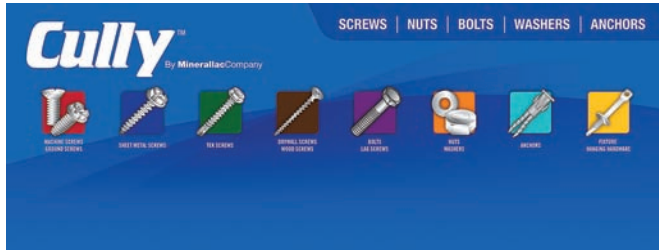

## Gravity Feed Jar Display

- Available in three and four foot displays to maximize showroom space.
- Heavy duty display with locking casters.
- Color coded headers.
- Stair stepped shelving to maximize product visibility.
- Wire dividers for product organization and space allocation.
- Magnetic shelf labels featuring product color code and UPC information.

Description	Part #	Qty
36" W x 75" H	94353	1
48" W x 75" H	94352	1

## Gravity Feed Gondola Headers

Description	Part #	Qty
36" Header	00067	1
48" Header	00068	1



DISPLAYS



## Gondola Display

Increase sales with our gravity feed gondola display and custom merchandising Plan-O-Gram program with qualifying order. Together we will design a custom merchandising Plan-O-Gram program to target your specific market needs. Contact a Minerallac Company representative for details

- Available in three and four foot displays.
- Low maintenance gravity feed display to promote high impulse buying.
- Clean and organized display presentation.
- Suitable for a wall installation or freestanding set-up.

Description	Part #	Qty
36" W x 54" H, Gondola	94354	1
36" W x 12" D, Shelf	94312	1
48" W x 54" H, Heavy Duty	94454	1
48" W X 66" H, Heavy Duty	94466	1
48" W x 10" D, Shelf	94410	1
48" W x 12" D, Shelf	94412	1
Caster Base for 36" Gondola	94356	1
Caster Base for 48" Gondola	94456	1

## Peg Hooks

Description	Part #	Qty
1/8" Gauge x 6" Long	94006	1
1/4" Gauge x 8" Long	94008	1

## Gondola Headers

Description	Part #	Qty
48" Header	00001A	1
36" Header	00002A	1



## Accusharp® Knife Sharpener Display

### Part #00037

- Attractive signage attached to a demo unit.
- No charge with qualifying order of 12 sharpeners.



## Accusharp® Knife Sharpener Floor Display

### Part #00046

- Free standing unit.
- Attention grabbing signage.
- No charge with qualifying order of 36 sharpeners.



## SOG® Display

### Part #00036

- High quality, lockable acrylic counter display.
- Designed to hold an assortment of SOG knives and multi-tools.
- No charge with qualifying order.



## Hex Power Bit Display

### Part #37999

- High quality acrylic counter display.
- Holds 24 1-3" bits and 6 4-6" bits.
- No charge with qualifying opening order. See page 141-142 for details.



## Plastic Boxes



Description	Part #
Single Compartment Plastic Box	93315
Double Compartment Plastic Box	93320

## Krylon®/Sprayon® Display

### Part #00047

- Gravity fed, 5 shelf freestanding unit.
- Attention grabbing header sign.
- Free with qualifying order of \$300 or more.



## Cully™ Screwdriver Counter Display

### Part #37125

- Maximize your POP sales with this great looking counter display.
- See page 136-138 for a full list of parts.



## Krylon®/Sprayon® Counter Display

### Part #37700

- Holds 18 cans of paint, chemicals or caulk.
- Attention grabbing header sign.
- Free with qualifying order of 72 cans/tubes.



# Displays

## Masonry Drill Bit Wall Mount Display

### Part #59761

- 10 peg wall mounting rack with attractive signage.
- No charge with qualifying order. See page 148 for details.



## Morse® Reciprocating Saw Blade Wall Mount Display

### Part #95328

- No charge with qualifying order.



## CrossFire® Display

### Part #19119

- No charge counter display with qualifying order.



## Shovel Hooks

### Part #00042

- Wall mounted peg hooks are designed to hold shovels in smaller spaces.
- Free with qualifying order of 12.

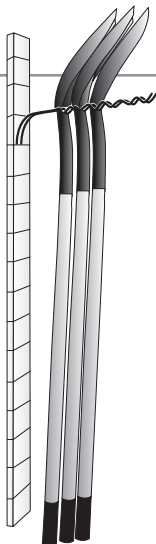

## Glove Wall Mount Display • Peg Hook

### Part #67598

- 10 peg wall mounting display with bold header sign.
- Place an opening order of \$300 to receive this glove rack and header at no additional charge.
- See pages 182-184 for glove selection.



## Counter Glove Display

### Part #67585

- Free with first time order of 24 pairs of work gloves.
- See pages 182-184 for glove selection.



## Morse® Hole Saw Wall Mount Display

### Part #86553

- No charge with qualifying order.



## Jobber Drill Display

### Part #91808

- High quality metal display with locking door.
- Holds up to 29 sizes.
- 15"W x 13"H x 8"D
- Choose from Trinidad, 118° or 135° jobber drills.



# Numerical Index

## 0

0	202
OB	202
OS	203
OSB	203
00001A	281
00002A	281
00036	282
00037	282
00042	283
00046	282
00047	282
00064	187
00067	280
00068	280
09382	150

## 1

1	202
1B	202
1S	203
1SB	203
10	202
10B	202
102	205
103	205
105	205
105SC	207
10030	122
10406	14
10408	14
10410	14
10412	14
10604	14
10606	14
10606TP	46
10608	14
10608TP	46
10610	14
10610TP	46
10612	14
10612J	14
10612TP	46
10616	14
10616J	14
10616TP	46
10620	14
10620TP	46
10624	14
10624J	14
10624TP	46
10628	14
10632	14
10632TP	46
10707	24
10707-6	24
10707J	24
10708	24
10708-6	24
10708J	24
10806	14
10806J	14
10806TP	46
10808	14
10808J	14
10808TP	46
10808XP	47
10810	14
10812	14
10812-6	14
10812J	14
10812SP	47
10812TP	46
10812XP	47
10816	14
10816-6	14
10816J	14
10816SP	47
10816TP	46

10816XP	47
10820	14
10820-6	14
10820J	14
10820TP	46
10820XP	47
10824	14
10824-6	14
10824J	14
10824TP	46
10828	14
10832	14
10832J	14
10832TP	46
10840	14
10840J	14
10848	14
110	205
11008	14
11008-6	14
11008J	14
11008SP	47
11008TP	46
11008XP	47
11010	14
11010J	14
11010TP	46
11012	14
11012-6	14
11012J	14
11012SP	47
11012TP	46
11012XP	47
11016	14
11016-6	14
11016J	14
11016SP	47
11016TP	46
11016XP	47
11020	14
11020-6	14
11020J	14
11020TP	46
11020XP	47
11024	14
11024-6	14
11024J	14
11024TP	46
11024XP	47
11028	14
11032	14
11032-6	14
11032J	14
11032TP	46
11040	14
11040J	14
11048	14
11048J	14
1105	210
11208	14
11208J	14
11208TP	46
11210	14
11212	14
11212J	14
11212TP	46
11216	14
11216J	14
11216TP	46
11220	14
11220J	14
11220TP	46
11224	14
11224J	14
11224TP	46
11228	14
11232	14
11232J	14
11232TP	46
11240	14
11240J	14
11248	14

11248J	14
11408	15
11408TP	46
11410	15
11412	15
11412TP	46
11416	15
11416TP	46
11420	15
11420TP	46
11424	15
11428	15
11432	15
11440	15
11448	15
115	205
1155C	207
120	205
121	205, 211
12406	39
12408	39
12412	39
12412J	39
12416	39
12416J	39
125	205, 211
12512	39
12606	21
12606TP	46
12608	21, 39
12608TP	46
12610	21, 39
12610TP	46
12612	21, 39
12612J	39
12612TP	46
12616	21, 39
12616J	21, 39
12616TP	46
12620	39
12620TP	46
12621	21
12624	39
12624TP	46
12625	21
12628	39
12632	39
12632TP	46
12633	21
12806TP	46
12808	21, 39
12808J	39
12808TP	21
12808XP	46
12810	21, 39
12810J	21, 39
12812	21, 39
12812J	21, 39
12812TP	46
12812XP	47
12816	21, 39
12816J	21, 39
12816TP	46
12820	39
12820TP	46
12820XP	47
12821	21
12821J	21
12824	39
12824J	39
12824TP	46
12825	21
12828	39
12832	39
12832J	39
12832TP	46
12833	21
12840	39
12848	39
12856	39

12864	39
130	205, 211
13008	21, 39
13008TP	46
13010	21
13010TP	46
13012	21, 39
13012J	21, 39
13012TP	46
13012XP	47
13016	21, 39
13016J	21, 39
13016TP	46
13016XP	47
13020	39
13020J	39
13020TP	46
13020XP	47
13021	21
13024	39
13024J	39
13024TP	46
13025	21
13028	39
13032	39
13032J	39
13032TP	46
13033	21
13036	39
13040	39
13048	39
13056	40
13064	40
13208TP	46
13212	21, 40
13212TP	46
13216	21, 40
13216TP	46
13220	40
13220TP	46
13221	21
13224	40
13224TP	46
13225	21
13232	40
13232TP	46
13240	40
13248	40
13256	40
13264	40
13408TP	46
13412	40
13412TP	46
13416	40
13416TP	46
13420	40
13420TP	46
13424	40
13432	40
13440	40
13448	40
13456	40
13464	40
135	205
13616	42
13624	42
13632	42
13716	41
137161lb	41
13726	41
137261lb	41
13736	41
137361lb	41
13748	41
137481lb	41
13812	42
13812J	42
13814	41
13815	41
13816	42
13820	42
13820J	42

13822	41
13824	42
13824J	42
13826	41
13828	42
13830	41
13832	42
13832J	42
13834	41
13836	42
13838	41
13840	42
13840J	42
13842	41
13848	42
13850	41
14WNW	230
140	205, 211
14016	42
14020	42
14022	41
14024	42
14026	41
14028	42
14030	41
14032	42
14036	42
14038	41
14040	42
14048	42
14300	126
14305	126
145	205, 211
14608TP	46
14612TP	46
14616TP	46
14620TP	46
14624TP	46
14808	20
14808J	20
14808TP	46
14809	23
14809-6	23
14809J	23
14810	20
14810J	20
14811	23
14811-6	23
14811J	23
14812	20
14812-6	20
14812J	20
14812TP	46
14813	23
14813-6	23
14813J	23
14816	20
14816-6	20
14816J	20
14816TP	46
14817	23
14817-6	23
14817J	23
14820	20
14820-6	20
14820J	20
14820TP	46
14821	23
14821-6	23
14821J	23
14824	20
14824J	20
14824TP	46
14828	20
14832	20
14832J	20
14840	20
14848	20
150	205, 211
15008	20
15008-6	20
15008J	20



# Numerical Index

15008TP	46	19013-6	17	19844	178	20720	34	22508TP	48
15010TP	46	19013J	17	19850	179	20720TP	48	22508XP	49
15012	20	19017	17	19852	179	20724	34	22512	31
15012-6	20	19017-6	17	19860	179	20724J	34	22512SP	49
15012J	20	19017J	17	19862	179	20724SP	49	22512TP	48
15012TP	46	19021	17	19870	179	20724TP	48	22512XP	49
15016	20	19021-6	17	19872	179	20732	34	22516	31
15016-6	20	19021J	17	19874	179	20732J	34	22516SP	49
15016J	20	19025	17	19880	178	20732TP	48	22516TP	48
15016TP	46	19025-6	17			20740	34	22516XP	49
15020	20	19025J	17			20748	34	22520	31
15020-6	20	19033	17			20808	34	22520TP	48
15020J	20	19033-6	17			20808SP	49	22524	31
15020TP	46	19033J	17			20812	34	22524TP	48
15024	20	19041	17			20812SP	49	22532	31
15024-6	20	19041J	17			20816	34	22532TP	48
15024J	20	19049	17			20816SP	49	22604XP	49
15024TP	46	19049J	17			20820	34	22606	31
15032	20	19100	176			20824SP	49	22606SP	49
15032-6	20	19101	176			21008	34	22606TP	48
15032J	20	19102	176			21008SP	49	22606XP	49
15048	20	19103	176			21012	34	22608	31
15212	20	19105	176			21012SP	49	22608SP	49
15216	20	19106	176			21016	34	22608TP	48
155	205, 211	19110	177			21016SP	49	22608XP	49
160	205, 211	19115	177			21020	34	22610	31
165	205	19119	283			21020SP	49	22612	31
170	205	19120	177			21024	34	22612SP	49
18020-6	45	19125	176			21024SP	49	22612TP	48
180201lb	45	19126	176			21032	34	22612XP	49
180205lb	45	19127	176			21032SP	49	22616	31
18022-6	45	19130	177			21040	34	22616SP	49
180221lb	45	19131	177			21048	34	22616TP	48
180225lb	45	19132	177			212	212	22616XP	49
18026-6	45	19135	176			2203	212	22620	31
180261lb	45	19136	176			221	212	22620TP	48
180265lb	45	19137	176			22200	188	22624	31
18132-6	45	19209	17			22202	188	22624SP	49
181321lb	45	19209J	17			22204	188	22624TP	48
181325lb	45	19213	17			22206	188	22628	31
18140-6	45	19213J	17			22208	188	22632	31
181405lb	45	19217	17			22210	188	22632TP	48
181401lb	45	19217J	17			22212	188	22632TP	48
18148-6	45	19221	17			22212	188	22704SP	49
181481lb	45	19221J	17			22214	188	22706SP	49
181485lb	45	19225	17			22216	188	22708	31
18264-6	45	19225J	17			22218	188	22708SP	49
182641lb	45	19233	17			22220	188	22708TP	48
182645lb	45	19233J	17			22222	188	22710TP	48
182801lb	45	19241	17			22224	188	22712	31
182805lb	45	19241J	17			22226	188	22712SP	49
182961lb	45	19249	17			22228	188	22712TP	48
182965lb	45	19249J	17			22230	188	22716	31
18609	17	19413	17			22240	188	22716J	31
18609J	17	19413J	17			22244	188	22716SP	49
18613	17	19417	17			22254	188	22716TP	48
18613J	17	19417J	17			22256	188	22720	31
18617	17	19421	17			22258	188	22720TP	48
18617J	17	19421J	17			22260	188	22724	31
18621	17	19425	17			22262	188	22724J	31
18621J	17	19425J	17			22264	188	22724SP	49
18625	17	19433	17			22280	188	22724TP	48
18625J	17	19433J	17			22282	188	22732	31
18809	17	19602	180			22284	188	22732TP	48
18809J	17	19604	180			22286	188	22740	31
18813	17	19608	180			22290	187	22748	31
18813-6	17	19610	180			22292	187	22748J	31
18813J	17	19612	180			22294	187	228	209, 212
18817	17	19804	178			22296	187	22804SP	49
18817-6	17	19805	178			22298	187	22806SP	49
18817J	17	19806	178			223	212	22808	32
18821	17	19807	178			22329	181	22808SP	49
18821-6	17	19808	178			22337	181	22808TP	48
18821J	17	19809	178			225	209, 212	22810	32
18825	17	19810	178			22504	31	22812	32
18825J	17	19811	178			22504SP	49	22812SP	49
18833	17	19812	178			22504XP	49	22812TP	48
18833J	17	19814	178			22506	31	22816	32
19009	17	19831	178			22506SP	49	22816SP	49
19009-6	17	19832	178			22506TP	48	22816TP	48
19009J	17	19840	178			22506XP	49	22820	32
19013	17	19843	178			22508	31	22820SP	49
						22508SP	49	22824	32

## 2

# Numerical Index

22824SP	49	26808J	25	30006TP	137	35001	137	37440	127
22832	32	26809	28	30008TP	137	35002	137	37450	156
22832SP	49	26809-6	28	30010TP	137	35003	137	37455	111-112
230	209, 212	26809J	28	30012TP	137	37009	139	37456	112
230SS	209, 212	26810	25	30014TP	137	37011	135	37457	112
23006	32	26810J	25	301	208	37014	136	37458	112
23008	32	26811	28	301SC	208	37016	136	37459	111-112
23008J	32	26811-6	28	305	208	37020	136	37460	111-112
23012	32	26811J	28	31000	137	37021	136	37461	111-112
23012J	32	26812	25	31106	139, 143	37022	136	37462	111-112
23016	32	26812-6	25	31108	139, 143	37023	137	37463	111-112
23016J	32	26812J	25	31110	139, 143	37100	138	37465	111-112
23020	32	26813	28	31112	143	37101	138	37466	111-112
23024	32	26813-6	28	31114	143	37103	138	37467	111-112
23024J	32	26813J	28	31206	137	37104	138	37468	111-112
23032	32	26816	25	31210	137	37105	138	37469	111-112
23032J	32	26816-6	25	31214	137	37107	138	37470	111-112
23040	32	26816J	25	32065	180	37108	138	37471	111-112
23298	182	26817	28	32066	180	37109	138	37472	111-112
23300	182	26817-6	28	32067	180	37111	138	37473	113
240	209, 212	26817J	28	32068	180	37112	138	37474	113
240SS	209, 212	26820	25	33304	146	37113	138	37475	113
2403	212	26820J	25	33305	146	37114	138	37476	113
24433	37	26821	28	33306	146	37115	138	37477	113
24449	37	26821-6	28	33307	146	37116	138	37478	113
24465	37	26821J	28	33308	146	37117	138	37479	113
245	209, 212	270	209	33309	146	37118	138	37480	113
245SS	209, 212	27008	25	33310	146	37119	138	37481	113
24608	37	27008-6	25	33311	146	37120	138	37482	111-112
24733	37	27008J	25	33312	146	37121	138	37485	113
24749	37	27010	25	33313	146	37122	138	37486	113
24765	37	27010J	25	33314	146	37123	138	37487	113
250	209, 212	27012	25	33315	146	37124	138	37488	113
250SS	209, 212	27012-6	25	33316	146	37125	282	37489	113
25049	37	27012J	25	33317	146	37150	135	37490	113
25065	37	27016	25	33318	146	37160	130-131	37491	113
255	209, 212	27016-6	25	33319	146	37161	130-131	37492	113
25508	74	27016J	25	33320	146	37162	130-131	37495	120
25508J	74	27020	25	33321	146	37163	130-131	37497	115, 117
25512	74	27020-6	25	33322	146	37164	130-131	37498	115-117
25512J	74	27020J	25	33323	146	37165	130-131	37499	115, 117
25516	74, 230	27024	25	33324	146	37166	130-131	37501	114-115, 117
25516J	74	27024-6	25	33325	146	37167	130-131	37502	115, 117
25520	74, 230	27024J	25	33326	146	37200	134	37504	114, 116
25520J	74	27032	25	33333	146	37204	168	37505	114, 116
25524	74, 230	27032-6	25	33335	146	37205	168	37508	118
25524J	74	27032J	25	33336	146	37206	168	37509	118
25532	74	27212	25	33400	189	37207	168	37510	118
25532J	74	27216	25	33402	189	37208	168	37511	118
25540	74	27216J	25	33404	189	37209	168	37513	118
25548	74	27220	25	33406	189	37216	168	37514	124
25606TP	48	275	209	33408	189	37218	168	37515	124
25608TP	48	280	209	33410	189	37250	130-131	37516	124
25612TP	48	285	209	33412	189	37251	130-131	37518	119
25616TP	48	290	209	33414	189	37253	130-131	37520	119
25620TP	48	292	209	33416	189	37256	130-131	37521	119
25624TP	48	294	209	33418	189	37257	130-131	37522	121
25716	74	29410	181	33420	189	37259	130-131	37523	121
25716J	74	29412	181	33422	189	37262	130-131	37524	120
25720	74	29418	181	33424	189	37263	130-131	37525	120-121
25724	74	29424	181	33426	189	37265	130-131	37528	119
25732	74	29430	181	33428	189	37267	130-131	37529	119
25808TP	48	29432	181	33430	189	37269	130-131	37530	124
25812TP	48	29434	181	33432	189	37271	130-131	37531	124
25816TP	48	29436	181	33434	189	37273	130-131	37566	114
25820TP	48	29438	181	33436	189	37275	130-131	37580	127
25824TP	48	29440	181	33438	189	37277	130-131	37582	127
260	209, 212	29442	181	33439	189	37279	130-131	37584	127
26008TP	48	29444	181	33440	189	37285	134	37586	127
26010TP	48			33441	189	37296	160	37587	127
26012TP	48			33442	189	37301	159	37588	127
26016TP	48			33443	189	37302	159	37590	127
26020TP	48			33444	189	37304	159	37591	127
26024TP	48			33446	189	37308	159	37595	121
26208TP	48			33448	189	37369	161	37596	187
26212TP	48			33450	189	37389	164	37597	187
26216TP	48			33452	189	37390	164	37600	187
265	209			33454	189	37393	165	37601	187
26606	25			33456	189	37395	164	37602	187
26606J	25			34001	137	37400	158	37603	187
26808	25			34002	137	37400C	158	37604	187
26808-6	25			34003	137	37404	158	37605	187

3

3	202
3B	202
3S	203
3SB	203
300	208
300A	208
300SC	208
30002	137
30003	137

# Numerical Index

37606	187	38561	140-142	39370	132	39914	96	40130	57
37607	187	38562	142	39373	132	39915	91	40130J	57
37608	187	38563	142	39411	95	39915-6	91	40135	57
37609	187	38564	142	39412	95	39915J	91	40135-6	57
37647	111-112	38601	140-141	39414	95	39916	91	40135HJ	57
37651	117	38602	141	39415	95	39916-6	91	40135J	57
37655	111-112	38602-5	141	39417	95	39916J	91	40137	57
37680	114, 116	38603	141	39418	95	39917	140	40140	57
37681	111-112	38604	141	39420	95	39920	93	40140-6	57
37700	282	38606	141	39421	95	39920-6	93	40140HJ	57
37760	160	38642	142	39422	95	39920J	93	40140J	57
37761	160	38648	140	39505	25	39921	93	40145	57
37763	162	38661	140, 142	39507	26	39921-6	93	40145J	57
37765	164	38662	142	39508	38	39921J	93	40150	57
37768	162	38704	143	39509	28	39922	93	40150HJ	57
37769	160	38705	139, 143	39514	38	39922J	93, 98	40150J	57
37770	160	38983	139, 143	39515	38	39923	93	40155	57
37771	160	38984	139, 143	39516	57	39923J	93	40225	59
37772	160	38985	139, 143	39517	68	39925	91	40230	59
37773	160	38988	139, 143	39518	64	39926	89	40235	59
37774	162	38990	139, 143	39519	66	39926J	89	40235J	59
37789	165	38992	139, 143	39525	30	39927	89	40240	59
37791	160	38994	139, 143	39526	30	39927J	89	40240J	59
37795	162	38996	139, 143	39527	32	39928	92	40250	59
37797	160	38998	139, 143	39532	30	39928J	92	40305	64
37876	161	38999	143	39534	32	39929	92	40305J	64
37918	163	39004	142	39536	30	39929J	92	40305SAEJ	64
37926	163	39004-5	142	39537	32	39930	92	40310	64
37927	161	39005	142	39538	30	39931	92	40310J	64
37929	165	39005-5	142	39539	74	39932	92	40310SAEJ	64
37967	161	39006	142	39540	74	39933	94	40315	64
37968	159	39014	142	39541	36	39933J	94	40315J	64
37972	163	39014-5	142	39546	37	39940	78	40317	64
37975	158	39015	142	39548	42	39940-6	78	40317J	64
37976	165	39015-5	142	39551	15	39940J	78	40325	64
37999	282	39016	142	39552	15			40325-6	64
38001	141	39018	140	39553	15			40325J	64
38002	141	39020	140	39554	40			40330	64
38003	141	39024	142	39555	40			40330J	64
38101	140-141	39025	142	39556	17			40330SAEJ	64
38102	141	39026	142	39557	17			40335	64
38103	141	39034	142	39558	23			40335-6	64
38104	141	39035	142	39562	18			40335J	64
38106	141	39036	142	39563	44			40340	64
38200	141	39101	101	39564	44			40340-6	64
38201	140-141	39102	101	39565	20			40340J	64
38201-5	141	39103	101	39566	20			40340SAEJ	64
38202	141	39104	142	39708	97			40345	64
38202-5	141	39105	142	39710	98			40345J	64
38203	141	39106	142	39710-6	98			40350	64
38203-5	141	39114	142	39711	98			40350J	64
38204	141	39312	132	39712	98			40402	60
38206	141	39314	132	39717	99			40405	60
38208	141	39316	132	39718	99			40410	62
38210	141	39318	132-133	39721	99			40411	60
38212	141	39319	132	39722	99			40412	62
38215	140	39320	132-133	39723	99-100			40414	62
38220	141	39322	132-133	39724	99-100			40416	60
38222	140	39324	132-133	39747	99			40420	60
38301	140-141	39325	132	39748	99			40425	60
38301-5	141	39328	132-133	39752	99			40425J	60
38302	141	39330	132	39753	100			40430	60
38302-5	141	39332	132	39754	99-100			40435	60
38303	141	39334	132	39756	99			40435J	60
38304	141	39335	132	39759	99			40440	60
38306	141	39336	132-133	39761	99			40480	59
38308	141	39338	132-133	39762	99			40480J	59
38401	140-141	39340	132-133	39763	99-100			40481	59
38402	141	39342	132	39763-6	99			40481J	59
38403	141	39343	132	39764	99-100			40482	59
38404	141	39344	132	39816	97			40482J	59
38406	141	39346	132-133	39816J	97			40483	59
38500	141	39348	132-133	39818	97			40483J	59
38501	140-141	39350	132	39819	97			40505	68
38501-5	141	39352	132	39820	98			40505J	68
38502	141	39354	132-133	39820-6	98			40510	68
38502-5	141	39356	132-133	39821	98			40510J	68
38503	141	39358	132-133	39822	98			40515	68
38503-5	141	39360	132-133	39908	97			40515J	68
38504	141	39362	132	39910	98			40517	68
38506	141	39364	132	39911	98			40517J	68
38520	141	39368	132-133	39912	98			40525	68

## 4

4	202	40330J	64
4B	202	40330SAEJ	64
4S	203	40335	64
4SB	203	40335-6	64
40003	134	40335J	64
40003NP	134	40340	64
40004	134	40340-6	64
40004NP	134	40340J	64
40005	134	40340SAEJ	64
40005NP	134	40345	64
40006	134-135	40345J	64
40006NP	134	40350	64
40007	134	40350J	64
40007NP	134	40402	60
40008	134	40405	60
40009	134	40410	62
40012	135	40411	60
40013	135	40412	62
40014	135	40414	62
40015	135	40416	60
40016	135	40420	60
40017	135	40425	60
40018	135	40425J	60
40019	135	40430	60
40020	135	40435	60
40021	134	40435J	60
40021NP	134	40440	60
40022	134	40480	59
40022NP	134	40480J	59
40103	57	40481	59
40105	57	40481J	59
40105J	57	40482	59
40110	57	40482J	59
40110J	57	40483	59
40115	57	40483J	59
40115J	57	40505	68
40120	57	40505J	68
40120J	57	40510	68
40122	57	40510J	68
40125	57	40515	68
40125-6	57	40515J	68
40125J	57	40517	68
40126	57	40517J	68
		40525	68

# Numerical Index

40525J	68	41325	61	50113	36	51107J	38	52240	29
40530	68	41331	61	50113J	36	51108	38	52240J	29
40530J	68	41336	61	50116	35	51108J	38	52248	29
40535	68	41341	61	50116J	35	51109	38	52248J	29
40535J	68	41415	61	50117	36	51109J	38	52249	37
40540	68	41420	61	50117J	36	51110	38	52265	37
40540J	68	41425	61	50120	35	51110J	38	52306SS	33
40545	68	41430	61	50120J	35	51111	38	52306SSJ	33
40545J	68	41435	61	50121	36	51112	38	52308SS	33
40605	62	42310	65	50121J	36	51112J	38	52308SSJ	33
40606	62	42315	65	50124	35	51113	38	52312SS	33
40606J	62	42325	65	50124J	35	51113J	38	52312SSJ	33
40610	62	42330	65	50125	36	51114	38	52316SS	33
40611	62	42335	65	50125J	36	51115	38	52316SSJ	33
40615	62	42340	65	50128	35	51116	38	52356	29
40616	62	42340J	65	50132	35	51116J	38	52364	29
40620	62	42345	65	50132J	35	51117	38	52364J	29
40621	62	42350	65	50133	36	51117J	38	52406	29
40621J	62	42505	67	50133J	36	51118	38	52406-6	29
40625	62	42510	67	50140	35	51208	52	52406J	29
40626	62	42515	67	50140J	35	51212	52	52408	29
40705	66	42515J	67	50141	36	51216	52	52408-6	29
40705J	66	42517	67	50141J	36	51412	52	52408J	29
40709	66	42525	67	50148	35	51416	52	52412	29
40709J	66	42525J	67	50148J	35	51420	52	52412-6	29
40710	66	42530	67	50149	36	51424	52	52412J	29
40710J	66	42535	67	50149J	36	51432	52	52416	29
40715	66	42540	67	50164	35	51512	52	52416-6	29
40715J	66	42540J	67	50306	35	51516	52	52416J	29
40720	66	42545	67	50308	35	51520	52	52420	29
40720-6	66	42550	67	50308J	35	51524	52	52420-6	29
40720J	66	43105	58	50312	35	51532	52	52420J	29
40725	66	43110	58	50312J	35	51706	52	52424	29
40725-6	66	43115	58	50316	35	51708	52	52424-6	29
40725J	66	43120	58	50316J	35	51712	52	52424J	29
40730	66	43122	58	50320	35	51716	52	52432	29
40730-6	66	43125	58	50320J	35	51720	52	52432-6	29
40730J	66	43125J	58	50324	35	51724	52	52432J	29
40733	66	43130	58	50324J	35	51806	52	52440	29
40733J	66	43135	58	50325	36	51808	52	52440J	29
40735	66	43140	58	50332	35	51812	52	52448	29
40735J	66	43305	65	50332J	35	51816	52	52448J	29
40740	66	43310	65	50340	35	51820	52	52516SS	33
40740J	66	43315	65	50340J	35	51820J	52	52516SSJ	33
40743	66	43320	65	50348	35	51824	52	52606	29
40743-6	66	43325	65	50348J	35	51824J	52	52606J	29
40743J	66	43330	65	50508	35	51832	52	52608	29
40745	66	43335	65	50512	35	52008	37	52608J	29
40745-6	66	43340	65	50516	35	52008J	37	52612	29
40745J	66	43345	65	50520	35	52012	37	52612J	29
40750	66	43350	65	50524	35	52012J	37	52616	29
40750J	66	43805	63	50532	35	52016	37	52616J	29
40755	66	43810	63	50540	35	52016-6	37	52620	29
40755J	66	43815	63	50548	35	52016J	37	52620J	29
40760	62	45432	147	50708	35	52020	37	52624	29
40760J	62	478C	231	50712	35	52020J	37	52624J	29
40762	62			50716	35	52024	37	52632	29
40762J	62			50716J	35	52024-6	37	52632J	29
40905	63			50720	35	52024J	37	52648	29
40910	63			50724	35	52032	37	52648J	29
40915	63			50732	35	52032-6	37	52716SS	33
40925	63			50740	35	52032J	37	52716SSJ	33
40925SS	63			50748	35	52048	37	52809	29
40925SSJ	63			50908	35	52064	37	52809-6	29
410C	231			50912	35	52133	37	52809J	29
410C100	231			50916	35	52149	37	52813	29
41110	58			50916J	35	52165	37	52813J	29
41115	58			50920	35	52206	29	52817	29
41120	58			50920J	35	52206J	29	52817J	29
41122	58			50924	35	52208	29	52821	29
41125	58			50924J	35	52208-6	29	52821J	29
41125J	58			50932	35	52208J	29	52825	29
41130	58			50940	35	52212	29	52825J	29
41130J	58			50948	35	52212J	29	52833	29
41135	58			50948J	35	52216	29	52833J	29
41135J	58			51103	38	52216J	29	52906SS	33
41140	58			51103J	38	52220	29	52906SSJ	33
41140J	58			51104	38	52220J	29	52908SS	33
41145	58			51104J	38	52224	29	52908SSJ	33
41310	61			51105	38	52224J	29	52912SS	33
41315	61			51105J	38	52232	29	52912SSJ	33
41320	61			51107	38	52232J	29	52916SS	33

5

5	202
5B	202
5S	203
5SB	203
500	244
500KC1	245
500KC1B	245
500KC2	245
500KC112	245
500KC114	245
500KC1234	245
500KC1234B	245
50050	245
50050B	245
50075	245
50075B	245
50108	35
50108J	35
50109	36
50109J	36
50112	35
50112J	35

# Numerical Index

52916SSJ	33	54820	51	55217J	73	55456	72	57224	69
52920SS	33	54824	51	55217USJ	73	55456J	72	57224J	69
52920SSJ	33	54824J	51	55220	72	55464	72	57232	69
52924SS	33	54828	51	55220J	72	55464J	72	57232J	69
52924SSJ	33	54832	51	55221	73	55512	70	57240	69
53006	30	54832J	51	55221J	73	55516	70	57240J	69
53006-6	30	54840	51	55221USJ	73	55520	70	57248	69
53006J	30	54840J	51	55224	72	55524	70	57248J	69
53008	30	54848	51	55224J	72	55532	70	57256	69
53008-6	30	54848J	51	55225	73	55540	70	57264	69
53008J	30	54856	51	55225J	73	55540J	70	57264J	69
53012	30	54864	51	55225USJ	73	55548	70	57416	69
53012-6	30	55008	72	55227	71	55556	70	57416J	69
53012J	30	55008J	72	55232	72	55564	70	57420	69
53016	30	55009	73	55233	73	55812	72	57420J	69
53016-6	30	55009J	73	55233J	73	55812J	72	57424	69
53016J	30	55009USJ	73	55233USJ	73	55813	73	57424J	69
53020	30	55012	72	55234	71	55813J	73	57432	69
53020J	30	55012J	72	55240	72	55813USJ	73	57432J	69
53024	30	55013	73	55240J	72	55816	71-72	57440	69
53024J	30	55013J	73	55241	73	55816J	72	57440J	69
53032	30	55013USJ	73	55241J	73	55817	73	57448	69
53032J	30	55016	72	55241USJ	73	55817J	73	57448J	69
53040	30	55016J	72	55242	71	55817USJ	73	57456	69
53040J	30	55017	73	55248	72	55820	72	57456J	69
53048	30	55017J	73	55248J	72	55820J	72	57464	69
53048J	30	55017USJ	73	55256	72	55821	73	57464J	69
53064	30	55020	72	55264	72	55821J	73	57472	69
53064J	30	55020J	72	55312	70	55821USJ	73	57480	69
53212	30	55021	73	55316	70	55822	71	57480J	69
53212J	30	55021J	73	55320	70	55822J	71	57488	69
53216	30	55021USJ	73	55324	70	55824	72	57496	69
53216J	30	55022	71	55332	70	55824J	72	57824	69
53220	30	55022J	71	55340	70	55825	73	57824J	69
53220J	30	55024	72	55348	70	55825J	73	57832	69
53224	30	55024J	72	55356	70	55825USJ	73	57840	69
53224J	30	55025	73	55364	70	55826	71	57848	69
53232	30	55025J	73	55408	72	55832	72	57848J	69
53232J	30	55025USJ	73	55408J	72	55832J	72	57856	69
53248	30	55026	71	55409	73	55833	73	57864	69
53248J	30	55026J	71	55409USJ	73	55833J	73	57864J	69
53264	30	55032	72	55412	72	55833USJ	73	57872	69
53264J	30	55032J	72	55412J	72	55834	71	57880	69
53608	38	55033	73	55413	73	55840	72	57888	69
53608J	38	55033J	73	55413J	73	55840J	72	57896	69
53612	38	55033USJ	73	55413USJ	73	55841	73	58031	86
53616	38	55034	71	55416	72	55841J	73	58031J	86
53708	38	55035	71	55416J	72	55841USJ	73	58132	85
53712	38	55040	72	55417	73	55842	71	58132J	85
53716	38	55040J	72	55417J	73	55848	72	58133	85
53716J	38	55041	73	55417USJ	73	55848J	72	58133J	85
53808	38	55041J	73	55420	72	55849	73	58148	85
53812	38	55041USJ	73	55420J	72	55850	71	58148J	85
53816	38	55048	72	55421	73	55856	72	58149	85
53816J	38	55048J	72	55421J	73	55856J	72	58149J	85
54108	51	55049	73	55421USJ	73	55864	72	58164	85
54110	51	55049J	73	55422	71	55864J	72	58165	85
54112	51	55049USJ	73	55422J	71	56108	52	58165J	85
54116	51	55050	71	55424	72	56112	52	58231	86
54120	51	55056	72	55424J	72	56116	52	58332	85
54124	51	55064	72	55425	73	56312	52	58333	85
54132	51	55112	70	55425J	73	56316	52	58333J	85
54208	51	55116	70	55425USJ	73	56320	52	58348	85
54212	51	55120	70	55432	72	56324	52	58348J	85
54216	51	55124	70	55432J	72	57016	69	58349	85
54216J	51	55132	70	55433	73	57016J	69	58349J	85
54220	51	55140	70	55433J	73	57020	69	58364	85
54224	51	55148	70	55433USJ	73	57020J	69	58364J	85
54232	51	55156	70	55434	71	57024	69	58365	85
54408	51	55164	70	55434J	71	57024J	69	58365J	85
54412	51	55208	72	55440	72	57032	69	58396	86
54416	51	55209	73	55440J	72	57032J	69	58396J	86
54420	51	55209J	73	55441	73	57040	69	58431	86
54424	51	55209USJ	73	55441J	73	57040J	69	58431J	86
54424J	51	55212	72	55441USJ	73	57048	69	58496	86
54432	51	55212J	72	55442	71	57048J	69	58496J	86
54440	51	55213	73	55448	72	57056	69	58531	86
54448	51	55213J	73	55448J	72	57056J	69	58548	85
54456	51	55213USJ	73	55449	73	57064	69	58548J	85
54464	51	55216	71-72	55449J	73	57064J	69	58549	85
54812	51	55216J	72	55449USJ	73	57216	69	58549J	85
54816	51	55217	73	55450	71	57220	69	58564	85

# Numerical Index

58564J	85	59515	93
58565	85	59515J	93
58565J	85	59520	89
58631	86	59520J	89
58631J	86	59521	89
58647	86	59522	93
58648	86	59522J	93
58648J	86	59604	108
58664	86	59604J	108
58664J	86	59605	108
58680	86	59606	108
58696	86	59606J	108
58696J	86	59608	108
58732	84	59608J	108
58742	84	59613	107
58743	84	59613J	107
58744	84	59614	106
58816	84	59614J	106
58817	84	59615	106
58818	84	59615J	106
58900	84	59616	106
59011	78	59616J	106
59011J	78	59617	106
59012	78	59617J	106
59012J	78	59618	107
59016	78	59620	107
59016-6	78	59625	108
59016J	78	59625J	108
59020	78	59626	108
59020-6	78	59626J	108
59020J	78	59635	107
59024	78	59640	107
59024J	78	59641	107
59032	78	59643	106
59032J	78	59645	106
59124	79	59702	107
59132	79	59703	107
59140	79	59704	107
59148	79	59705	107
59156	79	59706	107
59164	79	59708	107
59248	54	59710	107
59248J	54	59720	148
59250	54	59722	148
59251	54	59724	148
59251J	54	59726	148
59264	54	59728	148
59280	54	59730	148
59408	97	59732	148
59408J	97	59734	148
59410	97	59736	148
59410J	97	59738	148
59411	95	59740	148
59412	97	59761	283
59412J	97	59804	107
59414	97	59805	107
59416	95	59806	107
59416J	95	59808	107
59417	95	59810	107
59418	95	59904	148
59425	96	59906	148
59425J	96	59908	148
59431	99	59910	148
59431J	99	59912	148
59432	99	59914	148
59432J	99	59916	148
59433	99	59918	148
59440	100	59920	148
59450	96	59922	148
59504	96	59980	148
59504J	96	59984	148
59505	96	59986	148
59505J	96	59987	148
59506	96	59988	148
59506J	96	59990	148
59507	96	59991	148
59507J	96	59992	148
59510	91	59994	148
59510J	91	59996	148
59512	92	59998	148
59512J	92		

## 6

6	202
6B	202
6S	203
6SB	203
600	217
60002	90
60004	90
60004J	90
60006	90
60008	90
60010	217
60011	90
60012	90
60014	90
60016	90
60016J	90
60018	90
60018J	90
60020	90
60020J	90
60022	90
60024	90
60026	90
60026J	90
60028	90
60030	90
60112SS	36
60112SSJ	36
60116SS	36
60116SSJ	36
60120	88
60120J	88
60124SS	36
60124SSJ	36
60128	88
60128J	88
60132SS	36
60132SSJ	36
60136	88
60136J	88
60144	88
60144J	88
60152	88
60152J	88
60160	88
60164	88
602	217
602B	217
602BSS	217
60206	83
60206J	83
60212	83
60212J	83
60214	83
60214J	83
60216	83
60216J	83
60218	83
60218J	83
60236	83
60240	83
60242	83
60244	83
60248	83
60320	88
60320J	88
60328	88
60328J	88
60336	88
60336J	88
60344	88
60344J	88
60352	88
60352J	88
60360	88
60364	88
60364J	88
60402	83
60402J	83

60404	83	61164	103
60404J	83	61164J	103
60405	83	61165	103
60406	83	61165J	103
60406J	83	61166	103
60408	83	61166J	103
60410	83	61167	103
60440	83	61167J	103
60444	83	61168	103
60446	83	61168J	103
60448	83	61169	103
60450	83	61169J	103
60520	87	61170	103
60528	87	61170J	103
60536	87	61172	103
60544	87	61172J	103
60552	87	61174	103
60560	87	61174J	103
60564	87	61175	103
60602	82	61175J	103
60602J	82	61176	103
60604	82	61176J	103
60606	82	61177	103
60606J	82	61177J	103
60608	82	61179	103
60610	82	61179J	103
60610J	82	61180	103
60612	82	61180J	103
60612J	82	61181	103
60614	82	61181J	103
60616	82	61182	102
60618	82	61182J	102
60720	87	61183	102
60728	87	61183J	102
60736	87	61185	104
60736J	87	61185J	104
60744	87	61186	104
60752	87	61186J	104
60764	87	61187	104
60802	82	61187J	104
60804	82	61188	104
60806	82	61188J	104
60808	82	61189	104
60810	82	61189J	104
60812	82	61190	104
60814	82	61194	105
60816	82	61194J	105
61102	87	61195	105
61103	87	61197	105
61105	87	61197J	105
61107	87	61198	105
61108	87	61198J	105
61109	87	61200	105
61111	87	61201	105
61113	87	61202	105
61144	102	61202J	105
61144J	102	61203	105
61145	102	61203J	105
61145J	102	61204	105
61147	102	61204J	105
61147J	102	61218	79
61148	102	61218J	79
61148J	102	61226	79
61150	102	61226J	79
61150J	102	61232	79
61152	102	61248	79
61152J	102	61413	76
61154	102	61413J	76
61154J	102	61422	76
61155	102	61617	76
61155J	102	61617J	76
61156	102	61630	76
61156J	102	61630J	76
61157	102	61640	76
61157J	102	61640J	76
61160	103	61822	76
61160J	103	61822J	76
61162	103	61830	76
61162J	103	61830J	76
61163	103	61840	76
61163J	103	62003	88

# Numerical Index

62006.....	88	64364.....	75	67488.....	189	67720.....	170	70010.....	217
62028.....	81	64364J.....	75	67490.....	189	67722.....	170	70012.....	110
62028J.....	81	64380.....	75	67492.....	189	67724.....	170	70012J.....	110
62029.....	76	64380J.....	75	67494.....	189	67726.....	170	70016.....	110
62029J.....	76	64396.....	75	67496.....	189	67728.....	170	70016J.....	110
62036.....	81	64396J.....	75	67498.....	189	67730.....	170	70020.....	110
62036J.....	81	64399.....	75	67499.....	189	67740.....	171	70020J.....	110
62037.....	81	64496.....	75	67509.....	184	67742.....	171	70024.....	110
62052.....	81	64499.....	75	67510.....	184	67744.....	171	70024J.....	110
62052J.....	81	64510.....	75	67511.....	184	67746.....	171	70032.....	110
62053.....	81	64512.....	75	67512.....	184	67748.....	171	70032J.....	110
62236.....	81	646R.....	226	67551.....	185	67748.....	171	70040.....	110
62236J.....	81	646RS.....	227	67553.....	185	67752.....	171	70040J.....	110
62237.....	81	646RW.....	226	67555.....	185	67754.....	171	70048.....	110
62244.....	81	646RWS.....	227	67561.....	185	67756.....	171	70048J.....	110
62244J.....	81	648R.....	226	67563.....	185	67758.....	171	70105.....	59
62245.....	81	648RS.....	227	67565.....	185	67760.....	171	70105J.....	59
62248.....	81	648RW.....	226	67567.....	185	67762.....	171	701.....	217
62248J.....	81	648RWS.....	227	67569.....	185	67800.....	169	70110.....	59
62249.....	81	65000.....	53	67571.....	185	67802.....	169	70115.....	59
62260.....	81	65002.....	53	67573.....	185	67804.....	169	70120.....	59
62260J.....	81	65004.....	53	67575.....	185	67806.....	169	70120J.....	59
62280.....	81	65006.....	53	67577.....	185	67808.....	169	70122.....	59
62280J.....	81	65008.....	53	67579.....	185	67810.....	169	70125.....	59
62298.....	81	65010.....	53	67579CAMO.....	185	67812.....	169	70125J.....	59
62444.....	81	65012.....	53	67581.....	185	67814.....	169	70130.....	59
62444J.....	81	654R.....	226	67581CAMO.....	185	67816.....	169	70135.....	59
62460.....	81	654RS.....	227	67583.....	185	67818.....	169	70135J.....	59
62460J.....	81	66124.....	101	67583CAMO.....	185	67820.....	169	70137.....	59
62468.....	81	66124J.....	101	67584.....	185	67822.....	169	70140.....	59
62468J.....	81	66132.....	101	67585.....	283	67824.....	169	70140J.....	59
62488.....	81	66132J.....	101	67598.....	283	67826.....	169	70145.....	59
62498.....	81	66140.....	101	67600.....	183	67828.....	169	702.....	217
62656.....	81	66148.....	101	67601.....	183	67830.....	169	703.....	217
62672.....	81	66148J.....	101	67602.....	183	67832.....	169	70305.....	64
62680.....	81	66164.....	101	67604.....	183	67834.....	169	70305J.....	64
62696.....	81	66340.....	101	67608.....	183	67836.....	169	70310.....	64
62700.....	81	66348.....	101	67609.....	183	67838.....	169	70310J.....	64
62876.....	81	66348J.....	101	67611.....	183	67840.....	169	70315.....	64
62888.....	81	66356.....	101	67612.....	183	67842.....	169	70315J.....	64
62897.....	81	66364.....	101	67613.....	183	67844.....	169	70325.....	64
62898.....	81	66400.....	53	67618.....	183	67846.....	169	70325J.....	64
62900.....	81	66402.....	53	67622.....	183	67848.....	169	70330.....	64
62910.....	81	66404.....	53	67624.....	184	68006.....	91	70335.....	64
63028.....	77	66406.....	53	67625.....	184	68008.....	91	70335J.....	64
63029.....	77	66408.....	53	67626.....	184	68010.....	91	70337.....	64
63038.....	77	66410.....	53	67630.....	183	68012.....	91	70340.....	64
63039.....	77	66412.....	53	67632.....	183	68036.....	135, 155	70345.....	64
63132.....	77	66414.....	53	67634.....	183	68037.....	155	70405.....	60
63144.....	77	66466.....	54	67636.....	183	68038.....	135, 155	70410.....	60
63238.....	77	66467.....	54	67638.....	183	68039.....	155	70415.....	60
63239.....	77	67005.....	75	67640.....	183	68040.....	135, 155	70420.....	60
63256.....	77	67007.....	75	67642.....	183	68041.....	155	70425.....	60
63257.....	77	67009.....	75	67648.....	183	68042.....	155	70430.....	60
63276.....	77	67400.....	122	67650.....	183	68044.....	135, 155	70435.....	60
634R.....	226	67402.....	122	67652.....	183	68046.....	135, 155	70440.....	60
634RW.....	226	67404.....	122	67654.....	183	68047.....	155	70445.....	60
63444.....	77	67405.....	122	67658.....	184	68049.....	155	70505.....	67
63456.....	77	67410.....	122	67661.....	184	68080.....	155	70505J.....	67
63476.....	77	67420J.....	172	67662.....	184	68084.....	155	70510.....	67
63496.....	77	67421J.....	172	67663.....	184	68096.....	135, 155	70515.....	67
63664.....	77	67422J.....	172	67664.....	184	69001.....	135	70515J.....	67
63676.....	77	67423J.....	172	67665.....	184	69002.....	135	70525.....	67
63696.....	77	67424J.....	172	67671.....	184	69003.....	135	70525J.....	67
63898.....	77	67450.....	189	67672.....	184	69004.....	135	70530.....	67
64024.....	75	67452.....	189	67680.....	169	69005.....	135	70530J.....	67
64032.....	75	67454.....	189	67682.....	169	69006.....	135	70535.....	67
64040.....	75	67456.....	189	67684.....	169	69007.....	135	70535J.....	67
64048.....	75	67458.....	189	67686.....	169	69902.....	155	70537.....	67
64132.....	75	67460.....	189	67688.....	169	69904.....	155	70540.....	67
64132J.....	75	67462.....	189	67690.....	169	69950.....	108	70540J.....	67
64140.....	75	67464.....	189	67692.....	169			70545.....	67
64140J.....	75	67466.....	189	67694.....	169			70608.....	16
64148.....	75	67468.....	189	67695.....	184			70612.....	16
64148J.....	75	67470.....	189	67696.....	169			70616.....	16
64164.....	75	67472.....	189	67699.....	170			70620.....	16
64164J.....	75	67474.....	189	67700.....	170			70709.....	66
64180†.....	75	67476.....	189	67710.....	170			70710.....	66
64180J.....	75	67478.....	189	67712.....	170			70720.....	66
64252†.....	75	67480.....	189	67714.....	170			70720J.....	66
64264.....	75	67484.....	189	67716.....	170			70725.....	66
64280.....	75	67486.....	189	67718.....	170			70725J.....	66

## 7

7.....	202
7B.....	202
7S.....	203
7SB.....	203
700.....	217
70000.....	110
70002.....	110

# Numerical Index

70730	66	72828	22	76608	19	77420J	19	79240J	27
70730J	66	72832	22	76610	19	77424	19	79248	27
70740	66	72840	22	76612	19	77432	19	79248J	27
70743	66	72848	22	76616	19	77432J	19	79412	27
70745	66	73012	22	76616J	19	77440	19	79412J	27
70745J	66	73016	22	76620	19	77440J	19	79416	27
70808	16	73020	22	76624	19	77448	19	79416J	27
70810	16	73024	22	76736	80	77448J	19	79420	27
70812	16	73028	22	76748	80	78606	27	79424	27
70816	16	73032	22	76748J	80	78606SS	28	79424J	27
70820	16	73040	22	76760	80	78606SSJ	28	79432	27
70824	16	73048	22	76760J	80	78608	27	79432J	27
70832	16	73216	22	76780	80	78610	27	79440	27
71000	108	73220	22	76808	19	78612	27	79448	27
71001	108	73224	22	76808J	19	78616	27	79505	23
71008	16	73228	22	76810	19	78616SS	28	79505-6	23
71010	16	73232	22	76812	19	78616SSJ	28	79505J	23
71012	16	73240	22	76812J	19	78808	27	79508	23
71016	16	73248	22	76816	19	78808-6	27	79508-6	23
71016J	16	73416	22	76816J	19	78808J	27	79508J	23
71020	16	73420	22	76820	19	78808SS	28	79512	23
71020J	16	73424	22	76820J	19	78808SSJ	28	79512-6	23
71024	16	73432	22	76824	19	78810	27	79512J	23
71024J	16	73440	22	76824J	19	78810J	27	79516	23
71032	16	73448	22	76832	19	78812	27	79516-6	23
71032J	16	74002	109	76832J	19	78812-6	27	79516J	23
71040	16	74010	109	76840	19	78812J	27	79524	23
71105	63	74011	109	76840J	19	78816	27	79524-6	23
71110	63	74013	109	76848	19	78816-6	27	79524J	23
71115	63	74014	109	76848J	19	78816J	27	79532	23
71120	63	74212	50	76944	80	78816SS	28	79532-6	23
71125	63	74212J	50	76960	80	78816SSJ	28	79532J	23
71135	63	74216	50	76968	80	78820	27	79616	43
71212	16	74216J	50	76988	80	78824	27	79616J	43
71216	16	74220	50	76998	80	78824J	27	79617	44
71220	16	74220J	50	77008	18	79008	27	79617J	44
71224	16	74224	50	77008-6	18	79008-6	27	79618	43
71232	16	74232	50	77008J	18	79008J	27	79618J	43
71240	16	74240	50	77010	19	79008SS	28	79619	44
71412	16	74248	50	77012	18	79008SSJ	28	79619J	44
71416	16	74312	50	77012-6	18	79010	27	79620	44
71420	16	74316	50	77012J	18	79010J	27	79620-6	44
71424	16	74320	50	77016	18	79012	27	79620J	44
71432	16	74324	50	77016-6	18	79012-6	27	79622	44
71440	16	74332	50	77016J	18	79012J	27	79622-6	44
71448	16	74340	50	77020	18	79016	27	79622J	44
71921	107	74348	50	77020-6	18	79016-6	27	79623	43
71922	107	74412	50	77020J	18	79016J	27	79623J	43
71923	107	74416	50	77024	18	79016SS	28	79624	43
71924	107	74416J	50	77024-6	18	79016SSJ	28	79624-6	43
71931	107	74420	50	77024J	18	79020	27	79624J	43
71932	107	74420J	50	77028	19	79020-6	27	79625	44
71933	107	74424	50	77032	18	79020J	27	79625-6	44
71934	107	74424J	50	77032-6	18	79024	27	79625J	44
71961	107	74432	50	77032J	18	79024-6	27	79626	43
71962	107	74440	50	77040	19	79024J	27	79626-6	43
71963	107	74448	50	77040J	19	79024SS	28	79626J	43
71964	107	74612	50	77048	19	79024SSJ	28	79627	43
72010	109	74616	50	77048J	19	79028	27	79627J	43
72010SS	109	74620	50	77156	80	79032	27	79628	44
72011	109	74624	50	77172	80	79032-6	27	79628-6	44
72012	109	74632	50	77196	80	79032J	27	79628J	44
72012SS	109	74640	50	77208	19	79040	27	79629	44
72013	109	74648	50	77208J	19	79048	27	79629-6	44
72014	109	75608	22	77212	19	79048J	27	79629J	44
72015	109	75612	22	77212J	19	79212	27	79630	43
72016	109	75616	22	77216	19	79212-6	27	79630J	43
72018	109	75812	22	77216J	19	79212J	27	79632	43
72020	109	75816	22	77220	19	79216	27	79632-6	43
72608	22	75820	22	77220J	19	79216-6	27	79632J	43
72612	22	75832	22	77224	19	79216J	27	79634	44
72616	22	76012	22	77224J	19	79216SS	28	79634-6	44
72620	22	76016	22	77232	19	79216SSJ	28	79634J	44
72726	41	76020	22	77232J	19	79220	27	79635	44
72736	41	76024	22	77240	19	79220J	27	79635-6	44
72748	41	76028	22	77248	19	79224	27	79635J	44
72808	22	76032	22	77248J	19	79224J	27	79636	43
72810	22	76040	22	77408	19	79224SS	28	79636J	43
72812	22	76048	22	77412	19	79224SSJ	28	79637	44
72816	22	76528	80	77416	19	79232	27	79637-6	44
72820	22	76536	80	77416J	19	79232J	27	79637J	44
72824	22	76552	80	77420	19	79240	27	79840	43



# Numerical Index

79840J	43
79841	44
79841J	44
79843	44
79843-6	44
79843J	44
79845	43
79848	43
79848J	43
79849	44
79849J	44
79850	43
79851	44
79851-6	44
79851J	44
79964	43
79965	44
79972	43
79980	43
79981	44
79997	44

## 8

8	202
8B	202
8S	203
8SB	203
80006	55
80006-6	55
80006J	55
80007	55
80011	55
80011J	55
80014	189
80015	55
80016	55
80017	55
80017-6	55
80017J	55
80018	55
80020	55
80021	55
80022	55
80022J	55
80608	150
80609	150
80610	150
80612	150
80613	150
80614	150
80615	150
80616	150
80618	150
80620	150
80622	150
80624	150
80910	149
80911	149
80912	149
80913	149
80914	149
80916	149
80918	149
80920	149
81012SS	18
81012SSJ	18
81016SS	18
81016SSJ	18
81020SS	18
81020SSJ	18
81024SS	18
81024SSJ	18
81032SS	18
81032SSJ	18
81806	150
81807	150
81808	150
81809	150
81810	150
81811	150

81812	150
81813	150
81814	150
81815	150
81816	150
81817	150
81818	150
81820	150
81822	150
81824	150
82009	150
82012	150
82018	150
82024	150
82204	149
82205	149
82206	149
82207	149
82208	149
82303	149
82304	149
82305	149
82306	149
82307	149
82308	149
82404	149
82405	149
82406	149
82408	149
82608	26
82608J	26
82610	26
82612	26
82612J	26
82616	26
82616J	26
82808	26
82808J	26
82810	26
82810J	26
82812	26
82812J	26
82816	26
82816J	26
82820	26
82820J	26
82824	26
82824J	26
83008	26
83008J	26
83010	26
83010J	26
83012	26
83012-6	26
83012J	26
83016	26
83016J	26
83020	26
83020J	26
83024	26
83024J	26
85004	151
85005	151
85006	151
85007	151
85008	151
85009	151
85010	151
85011	151
85012	151
85013	151
85014	151
85015	151
85016	151
85018	151
85020	151
85022	151
85024	151
86209	153
86212	153
86214	153
86216	153

86217	153
86218	153
86219	153
86220	153
86222	153
86224	153
86226	153
86228	153
86232	153
86234	153
86236	153
86238	153
86240	153
86242	153
86244	153
86246	153
86248	153
86252	153
86254	153
86256	153
86258	153
86260	153
86264	153
86266	153
86268	153
86270	153
86272	153
86276	153
86280	153
86284	153
86288	153
86292	153
86296	153
86298	153
86301	154
86302	154
86303	154
86304	154
86305	154
86306	154
86314	154
86322	154
86328	154
86338	154
86511	152
86512	152
86514	152
86522	153
86528	154
86530	154
86540	152
86544	152
86545	152, 154
86553	283
86554	152
86556	152, 154
86558	152
86560	152
86566	152
86618	157
86624	157
86632	157
86633	157
86634	157
86637	157
86638	157
86640	157
86641	157
86644	157
86650	157
86655	157
86660	157
86665	157
86670	157
86708	152
86712	152
86714	152
86718	152
86722	152
86724	152
86814	152
86922	151

## 9

9	202
9B	202
9S	203
9SB	203
90010	190
90020	190
90024	190
90028	190
90032	190
90036	190
90040	190
90050	190
90052	190
90054	190
90056	190
90058	190
90060	190
90062	190
90064	190
90066	190
90068	190
90072	190
90074	190
90100	228
90108	216
90108J	216
90109	216
90112	216
90112J	216
90113	216
90116	216
90116J	216
90117	216
90214	158
90215	158
90228	158
90229	158
90500	228
90505	228
90600	228
90605	228
91597	144
91599	144
91600	144
91601	144
91602	144
91603	144
91604	144
91605	144
91606	144
91607	144
91608	144
91609	144
91610	144
91611	144
91612	144
91613	144
91614	144
91615	144
91616	144
91617	144, 155
91618	144
91619	144
91620	144
91621	144
91622	144
91623	144
91624	144, 155
91625	144
91626	144

91627	144
91628	144
91629	144
9170F	155
91707	144, 155
91721	155
91725	144, 155
91729	144, 155
91736	155
91801	144
91802	144
91804	144
91805	147
91806	144
91807	147
91808	283
91809	147
91901	145
91902	145
91903	145
91904	145
91905	145
91906	145
91907	145
91908	145
91909	145
91910	145
91911	145
91912	145
91913	145
91914	145
91915	145
91916	145
91917	145
91918	145
91919	145
91920	145
91921	145
91922	145
91923	145
91924	145
91925	145
91926	145
91927	145
91928	145
91929	145
91945	145
91949	145
92050	149
92051	149
92052	149
92053	149
92054	149
92055	149
92056	149
92057	149
92058	149
92500	139
92600	139
92602	139-140
92627	146
92628	146
92629	146
92630	146
92631	146
92632	146
92706	139, 143
92707	139, 143
92709	139, 143
92710	139, 143
92711	139, 143
92718	139, 143
92720	139, 143
93315	282
93320	282
94006	281
94008	281
9408S	230
9410A	230
9410S	230
9412S	230
94312	281

94315	173
94317	173
94320	173
94325	173
94330	174
94340	174
94352	280
94353	280
94354	281
94356	281
94357	174
94361	173
94362	173
94363	173
94364	173
94365	173
94366	173
94368	173
94369	173
94394	174
94396	174
94410	281
94412	281
94422	110
94426	110
94428	110
94430	110
94433	174
94434	174
94435	174
94436	174
94454	281
94456	281
94466	281
94605	175
94606	175
94607	175
94614	175
94615	175
94616	175
94617	175
94618	175
94625	175
94628	175
94635	175
94636	175
94638	175
94639	175
94640	175
94641	175
95000	186
95002	186
95004	186
95006	186
95008	186
95010	186
95012	186
95014	186
95050	56
95052	56
95054	56
95070	56
95072	56
95074	56
95090	172
95092	172
95094	172
95096	172
95098	172
95100	172
95102	172
95120	186
95122	186
95124	186
95126	186
95128	186
95130	186
95132	186
95134	186
95136	186
95138	186

95150	56
95151	56
95152	56
95154	56
95156	56
95158	56
95168	56
95170	56
95190	56
95192	56
95194	56
95328	283
96000	124
96002	129
96010	125
96030	125
96035	126
96040	125
96042	155
96046	156
96047	156
96050	125
96055	129
96058	129
96059	129
96060	125
96062	129
96064	129
96066	129
96070	124
96140	125
96150	125
96160	186
96230	128
96232	129
96234	128
96236	128
96238	128
96240	128
96242	128
96244	128
96246	129
96248	129
96260	157
500100	245
500100B	245

## A

A2-1/2 600	218
A2-1/2 600B	218
A0600	218
A0600B	218
A1600	218
A1600B	218
A2600	218
A2600B	218
A3600	218
A3600B	218
A4600	218
A4600B	218
A5600	218
A5600B	218
ABC25	248
APS	237
APS50	237
APS75	237
APS100	237
APSK1	237
APSKC1234	237
APSPCTF	257

## B

BA	84, 232
BA50	250
BA75	250
BAKC38	250
BAKC1234	250
BAR	220
BB	84

BBC	258
BC	84
BC18	244
BC18KC1	239
BC18KC2	239
BC18KC38	239
BC18KC112	239
BC18KC114	239
BC18KC1234	239
BC18ST	244
BC516	244
BC516KC1	239
BC516KC2	239
BC516KC38	239
BC516KC112	239
BC516KC114	239
BC516KC1234	239
BC516ST	244
BC916	244
BC916KC1	239
BC916KC2	239
BC916KC38	239
BC916KC112	239
BC916KC114	239
BC916KC1234	239
BC916ST	244
BC1850	239
BC1875	239
BC18100	239
BC51650	239
BC51675	239
BC516100	239
BD	84
BE	84
BJNP	228
BJNPH	228
BJW4	232
BJW6	232
BMB16	220
BMB16D	220
BMB24	220
BMB24D	220
BO	232
BRS2	227
BRS15	227
BS18	221
BST	222
BXC	250

## C

CBS18HIC50	213
CBS18HIC50APS	214
CBS18HIC50ST	213
CBS18HIC75	213
CBS18HIC75APS	214
CBS18HIC75ST	213
CBS18HIC100	213
CBS18HIC100APS	214
CBS18HIC100ST	213
CBS18HIC5018	219
CBS18HIC7518	219
CBS18HIC10018	219
CBS18HIC50516	219
CBS18HIC75516	219
CBS18HIC100516	219
CBS18KC1	213
CBS18KC1APS	214
CBS18KC1ST	213
CBS18KC38	213
CBS18KC38APS	214
CBS18KC38ST	213
CBS18KC118	219
CBS18KC1234	213
CBS18KC1234APS	214
CBS18KC1234ST	213
CBS18KC1516	219
CBS18KC3818	219
CBS18KC38516	219
CBS18KC123418	219
CBS18KC1234516	219

## D

CC1538P(B)	269
CC1538Q	275
CG1738I	275
CG2025Q	275
CG2050Q	275
CG1525K	275
CG1538K	275
CG1538M(B)	269
CG1738K	275
CG2038M(B)	269
CG2050Q	275
CG2063T(B)	269
CG3090N(B)	269
CP1225K	274
CP1525K	274
CP1531K	274
CP1550K	274
CP1725K	274
CP2025K	274
CP2775S	274
CPRS25J	171
CULWM09	191
CULWM09LT	191
CULWM045	191
CULWM123	191
CULWM130	191
CULWM145	191
CULWM190	191
CULWM190AZ	191
CULWM4690	191
CULWMABC	191
CULWMAZ	191
CULWMAZ015	191
CULWMBA	192
CULWMFA	192
CULWMINST	191
CULWML1	191
CULWMNEMA	192
CULWMRC	192
CULWMT1	191
CULWMVOLT	192

DC2050Q	272
DC2063Q	272
DC2063S	272
DG1538K	272
DG1575E	272
DG1738K(S)	273
DG2050Q	272
DG2063Q	272
DG2063Q-#4	273
DG2063Q-#6	273
DG2090S	272
DG2588S	272
DG2590S	272
DG3090W	272
DG3090W(H)	272
DG3097W	272
DG3597W	272
DLS1	223
DR20	229
DR30	229
DR40	229
DWC1	224
DZ1738K	271
DZ1738K(S)	273
DZ2063Q	271
DZ2063Q(F)	273
DZ2063S	271
DZ2063S(S)	273
DZ3090W	271

## E

ES137S	167
ES200S	167
ES200SV	167
ES1150	167

## F

F2A	238
F2B	238
F2C	238
F2D	238
F2E	238
F2F	238
F2G	238
F4A	238
F4B	238
F4C	238
F4D	238
F4E	238
F4F	238
F4G	238
F8A	238
F8B	238
F8C	238
F8D	238
F8E	238
F8F	238
F8G	238
FB06	222
FB023	222
FB0234	222
FH116	249
FH532	249
FS1	236
FS2	236
FS3	236
FS4	236
FSBX	236
FT	254

## G

G100	227
GWC1	215

## H

H12	211
-----	-----

# Numerical Index

H16	211	IPS75C	265
H16A	211	IPS75D	265
H30	207	IPS75P	265
H40	207	IPSS502	265
H45	207	IPSS503	265
H50	207	IPSS504	265
H55	207	IPVC1HA	264
H60	207	IPVC1HC	264
H65	207	IPVC1HF	264
H70	207	IPVC1HR	264
H75	207	IPVC2A	264
H80	207	IPVC2C	264
H85	207	IPVC2F	264
H90	207	IPVC2R	264
H92	207	ISE13A	263
H94	207	ISE14A	263
H95	207	ISE18U	263
H96	207	ISE22U	263
H97	207	ISE23U	263
H98	207	ISER10	266
HD260	210	ISER20	266
HD270	210	ISER30	266
HD280	210	ISER40	266
HD290	210	ISEU50	266
HD292	210	ISEU60	266
HD294	210	ISEU70	266
HD295	210	ISEU80	266
HD296	210		
HD297	210		
HD298	210		
HIC50	234		
HIC75	234		
HIC100	234		
HIC5050	235		
HIC5075	235		
HIC7575	235		
<b>I</b>			
I10A	263		
I10C	263		
I10G	263		
I10HA	263		
I10HC	263		
I10HFA	263		
I10HFC	263		
I10HFG	263		
I10HFR	263		
I10HG	263		
I10HR	263		
I10R	263		
I12A	263		
I12C	263		
I12FA	263		
I12FC	263		
I12FG	263		
I12FR	263		
I12G	263		
I12R	263		
I12S	263		
I13A	263		
I15A	263		
IBT251B	266		
IBT251W	266		
INS66	266		
IPN1A	264		
IPN1C	264		
IPN1HFA	264		
IPN1HFC	264		
IPN1R	264		
IPN2A	264		
IPN2C	264		
IPN2FA	264		
IPN2FC	264		
IPN2FR	264		
IPN2R	264		
IPS50A	265		
IPS50C	265		
IPS50E	265		
IPS50P	265		
IPS75A	265		
<b>J</b>			
J200	225		
J200ABC25	225		
J200APS	225		
J200B	225		
J200B500	225		
J200B600	225		
J200BBC18	225		
J200BBC516	225		
J200BBC916	225		
J200SFC18	225		
J200SFC516	225		
J200SFC916	225		
J200VBC25	225		
J200500	225		
J200600	225		
<b>K</b>			
K0B	203		
K1B	203		
K2B	203		
KC1	234		
KC2	234		
KC38	234		
KC38KC1	235		
KC38KC1234	235		
KC38T	234		
KC112	234		
KC114	234		
KC1234	234		
KC1234KC1234	235		
KC1234T	234		
K050	190		
K075	190		
K0100	190		
K0125	190		
K0150	190		
K0200	190		
KOSORT	190		
<b>L</b>			
LSBAR	223		
<b>M</b>			
MED2	211		
MED3	211		
MED5	211		
MED7	211		

MED9	211		
MED12	211		
MED12A	211		
MED13	211		
MED13A	211		
MED14	211		
MED16	211		
MED30	206		
MED30SS	206		
MED40	206		
MED40SS	206		
MED45	206		
MED45SS	206		
MED50	206		
MED50SS	206		
MED55	206		
MED55SS	206		
MED60	206		
MED60SS	206		
MED65	206		
MED70	206		
MED70SS	206		
MED75	206		
MED80	206		
MED80SS	206		
MED85	206		
MED90	206		
MED90SS	206		
MINE28	206		
MINE30	206		
MINE40	206		
MINE45	206		
MINE50	206		
MINE55	206		
MSU050EG	215		
MSU075EG	215		
MSU100EG	215		
MSU125EG	215		
MSU150EG	215		
MSU200EG	215		
MSU250EG	215		
MSU300EG	215		
MSU350EG	215		
MSU400EG	215		
<b>N</b>			
NC06	277		
NC10	277		
NC16	277		
ND212	277		
ND213	277		
ND312	277		
ND313	277		
ND1900	277		
NK06	276		
NK16	276		
NK20	276		
NP3	228		
NP6	228		
NP6M	228		
NP12	228		
NP18	228		
<b>O</b>			
OR	221		
<b>P</b>			
P	246		
P50	247		
P75	247		
P100	247		
PBA	232		
PCTF	257		
PH	246		
PH14T	247		
PH38T	247		
PHPSR	247		

PKC1	248		
PKC38	248		
PKC114	248		
PKC1234	248		
PS50	210		
PS75	210		
PS100	210		
PS125	210		
PS150	210		
PS200	210		
PS250	210		
PS300	210		
PS400	210		
PSF18	243		
PSF18R	243		
PSF516	243		
PSF516R	243		
PSF916	243		
PSF916R	243		
<b>R</b>			
R14T	258		
R38T	258		
R1438N	258		
R1814	242		
R1814T	242		
R1838	242		
R1838T	242		
R51614	242		
R51614T	242		
R51638	242		
R51638T	242		
R91614	242		
R91614T	242		
R91638	242		
R91638T	242		
RA14	241		
RA14T	241		
RA38	241		
RA38T	241		
RA1438N	241		
RBAR	220		
RC50	171		
RC50J	171		
RC75	171		
RC75J	171		
RF11614T	249		
RF11638T	249		
RF53214T	249		
RF53238T	249		
RO14	241		
RO14T	241		
RO38	241		
RO38T	241		
RO1438N	241		
RSS	172		
RSSJ	172		
<b>S</b>			
S1900	252		
SB50	253		
SB75	253		
SB100	253		
SBC	252		
SBKC1	253		
SBKC38	253		
SBKC1234	253		
SBS	253		
SBS3.5	253		
SBS6	253		
SBX	250		
SCH48	231		
SCT2	224		
SCT3	254		
SCX1W	224		
SCX1XL	224		
SFC18	246		
SFC18KC1	240		
SFC18KC2	240		

SFC18KC38	240		
SFC18KC112	240		
SFC18KC114	240		
SFC18KC1234	240		
SFC18PCTF	257		
SFC516	246		
SFC516KC1	240		
SFC516KC2	240		
SFC516KC38	240		
SFC516KC112	240		
SFC516KC114	240		
SFC516KC1234	240		
SFC516PCTF	257		
SFC916	246		
SFC916KC1	240		
SFC916KC38	240		
SFC916KC1234	240		
SFC1850	240		
SFC1875	240		
SFC18100	240		
SS	251		
SS50	251		
SS75	251		
SS100	251		
SSKC1	251		
SSKC1234	251		
SSS	172		
SSSJ	172		
<b>T</b>			
TB	255		
TB50	256		
TB75	256		
TB100	256		
TBAR	223		
TBKC1	256		
TBKC38	256		
TBKC1234	256		
TBT	255		
TS	255		
TS50	256		
TS75	256		
TS100	256		
TSK1	256		
TSK1C38	256		
TSK1234	256		
TST	255		
<b>V</b>			
VBC25	248		
<b>W</b>			
WBF1	229		

## Symbols

<b>3-Piece Knock-Out Seals</b> .....	190
<b>6-in-1 Economy Screwdriver</b> .....	136
<b>10 Person First Aid Kit</b> .....	182
<b>13-in-1 Ratcheting Screwdriver</b> .....	136
<b>14-in-1 HVAC Screwdriver</b> .....	136
<b>15-in-1 MEGAPRO Screwdriver, Stainless Steel</b> .....	134
<b>15-in-1 Shaftlock 2 Screwdriver</b> .....	137
<b>15-in-1 Tamperproof 2 Screwdriver</b> .....	136
<b>16-in-1 MEGAPRO Screwdriver</b> .....	135
<b>25 Person First Aid Kit</b> .....	182
<b>118° Point</b>	
High Speed Jobber Drills .....	144
<b>135° Point</b>	
High Speed Jobber Drills .....	145
Trinado Heavy-Duty Drills .....	146

## A

<b>Accusharp® Knife Sharpener</b> ..	158
<b>Acoustical</b>	
Eye Lags .....	54
Eye TekS .....	54
Lighting	
Support Assembly .....	223
Troffer Fastener.....	254
T-Bar	
Box to T-Bar Fastener.....	223
Drop Wire Clip .....	224
Fasteners .....	261–262
Hanger, Two Piece.....	224
Scissor Clips, Two Piece .....	224
Twist on T-Bar Hanger.....	254
Wedge Anchors .....	76
<b>Acrylic Enamel Paint</b>	
Krylon Industrial Tough Coat ..	113
<b>Adhesive</b>	
Firestop .....	128–129
Industrial .....	125
Repositionable, Easy Tack .....	121
Roof Cement.....	125
Silicon Sealant.....	124
Splice Kits.....	167
<b>All Purpose Rags &amp; Scrubs</b> .....	127
Scrubs-In-A-Bucket.....	127
<b>All Thread Rod (ATR)</b>	
Threaded Rod.....	107
Size Reference Charts .....	260
<b>Anchor Kits</b>	
Double Drywall .....	78
Expander Anchor .....	100
EZ Ancor.....	91
EZ Toggle .....	89
Green Plug .....	96

Hangermate .....	106
Red Plastic Conical .....	97–100
SnapSkru .....	94
Tapcon .....	88
Toggler Alligator Solid Wall.....	95
Yellow Winged .....	99–100
<b>Anchors</b>	
Acoustical Wedge .....	76
Alligator Solid Wall	
Plastic Toggler .....	95
Double Drywall .....	78
Flat Head Split Bolt.....	79
Green Plug .....	96
Hollow Wall	
Phillips/Slotted .....	90
Phillips/Slotted with Drive Point .....	90
Lag Screw Shield .....	82
Lead, Machine Screw .....	83
Lead, Sheet Metal or Wood Screw .....	82
Nail-In	
Nylon .....	79
Zamac “Hammer Drive” .....	78
Plastic Anchors	
Expander.....	100
Red Conical.....	97–98
Yellow Winged.....	99
Self-Drilling	
EZ Ancors	
#6 Plastic Lite .....	93
#6-8 Zinc Alloy.....	92
#8 Plastic.....	93
#8 Zinc Alloy .....	91
Triple Pack .....	92
Sleeve Anchor .....	76
SnapSkru SP Toggler .....	94
Steel Drop-In.....	83
Strike Set .....	77
Tapcon Concrete	
Flat Head Phillips .....	87
Hex Washer Head Slotted .....	88
Toggle Bolt	
EZ Toggle .....	89
Plastic Toggler.....	91
Toggler Snaptoggle .....	84
with Wings	
Mushroom Head	
Slotted/Square .....	85
Mushroom Head	
Phillips/Slotted .....	85
Round Head Slotted .....	86
Toggle Bolt Wings .....	86
Wall Dog.....	96
Wedge Anchor, Trubolt .....	80–81
Stainless Steel .....	80
<b>Anti-Short Bushings</b> .....	172
<b>Auger Bits</b>	
6" Ship .....	150

17" Ship.....	150
Extensions.....	150
Sharpening File .....	150

## B

<b>Bar Joist Washers</b> .....	232
<b>Barricade Tape</b> .....	175
<b>Beam Clamp</b>	
Malleable .....	217
Spring Steel.....	244, 246
Universal .....	217
<b>Beam Clamp Assemblies</b>	
Cable Support J Hook.....	225
Cable Tie Fastener .....	257
Conduit	
Conduit & Box Support .....	219
Spring Steel	
Hammer On ... 239–240, 246	
Set Screw .....	245
Steel .....	218
Rod/Wire Hanger .....	242
Strap Hangers .....	243
Threaded Rod Hangers .....	242
<b>Belleville Washers</b> .....	63
<b>Bell Hanger Bits, Wood</b> .....	149
<b>Bell &amp; Thermostat Staples</b> .....	266
<b>Belts</b> .....	132
<b>Bits (see Drill Bits &amp; Driver Bits)</b>	
<b>Blink, SOG</b> .....	162
<b>Blow Twine, Polypropylene</b> .....	170
<b>Bolts</b>	
Anchors.....	83
Cap Screws, Hex Head	
Grade 2 .....	71–72
Grade 5 .....	73
Silicon Bronze .....	51
Stainless Steel .....	50
Carriage Bolts.....	70
Eye Bolts with Hex Nuts.....	75
Hex Lag Screws .....	69
Stove Bolts .....	74, 230
U-Bolts .....	75
<b>Box Support</b>	
Bar .....	258
Beam .....	257, 244
Conduit & Box .....	213
Wire & Rod Clip.....	214
Beam Clamp .....	219
Far Side.....	223, 253
Flange .....	218
Screwless .....	222
Stud	
Stabilizer.....	222
Mounting Bracket.....	220–221
Box to Bar .....	220
Fastener.....	251–252
T-Bar .....	223, 255
Wire .....	237
<b>Brackets</b> .....	232

## C

<b>Bridle Rings</b> .....	226
Cable Support.....	227
<b>Bushings</b>	
Anti-Short.....	172
Knock-Out.....	172
Steel Stud .....	172, 227
<b>Cabinet Screwdrivers</b> .....	138
<b>Cable Clip</b>	
Flexible Conduit/Cable	
Flange .....	236, 238
Flexible Conduit/Cable Stud... ..	250
<b>Cable Connectors</b> .....	171
<b>Cable Protection</b>	
Nail Plates .....	228
Stud Grommets .....	172, 227
<b>Cable Support</b>	
Bridle Rings.....	226–227
D-Rings.....	229
J-Hooks .....	225
Service Entrance	
One-Hole Straps.....	211
Two-Hole Straps.....	212
Staples.....	263–266
Ties .....	188
Tie Fasteners.....	227
<b>Cable Ties</b> .....	187–188
Fastener .....	257
Kits.....	187
Mounting Bases.....	188
Mounting Ties.....	188
Tensioning Tool.....	187
<b>Cap Screws, Hex Head</b>	
Grade 2 .....	71–72
Grade 5 .....	73
Silicon Bronze .....	51
Stainless Steel.....	50
<b>Cap Nuts, Specialty</b> .....	61
<b>Carbide Drill Bits</b>	
Rotary/Percussion .....	148
SDS Rotary/Hammer .....	148
Straight Shank, Rotary Only... ..	148
<b>Carbide Grit Hole Saws</b> .....	154
<b>Carbide-Tipped Masonry Drill Bits</b> .....	87
<b>Carbon Steel &amp; Hex Shank Taps</b>	
Carbon Steel Taps.....	155
Wrenches.....	155
Drill Set .....	155
<b>Carriage Bolts</b> .....	70
<b>Carton Sealing Tape</b> .....	174
<b>Caulk</b>	
Firestop .....	129
Gun .....	124, 129
Silicone .....	124
<b>Ceiling Cover Plate</b> .....	190
<b>Chain</b>	
Double Loop Tenso .....	109

- Jack ..... 109
    - Stainless ..... 109
  - S-Hooks ..... 110
  - Cleaners**
  - Contact ..... 116
  - Electronic ..... 117
  - General Purpose ..... 120
  - Glass ..... 120
  - Rags ..... 127
  - Scrubs ..... 127
  - Selection Guide ..... 114–115
  - Closed Clip** ..... 210
  - Coarse Thread Screws**
  - Drywall, Phillips ..... 44
  - Common Nails** ..... 276
    - Galvanized ..... 276
    - Copperclad ..... 277
    - Size Guide ..... 276
  - Concrete/Masonry Anchors**
  - Acoustical Wedge ..... 76
  - Flat Head Split Bolt,
    - Zinc-Plated Steel ..... 79
  - Lag Screw Shields ..... 82
  - Lead Machine Screw ..... 83
  - Lead Screw ..... 82
  - Nail-In
    - Light Duty ..... 79
    - Zamac “Hammer” Drive ..... 78
  - Sleeve, Medium Duty ..... 76
  - Steel Drop-In ..... 83
  - Strike Set, Solid Concrete ..... 77
  - Tapcon ..... 87–88
  - Wedge ..... 81
    - Stainless Steel ..... 80
  - Condrive Installation Tool**
  - Kits ..... 87
  - Conduit**
  - Beam Clamp
    - Assembly ..... 218, 239, 245
  - Clip ..... 234, 236
  - Conduit & Box
    - Support ..... 213–214, 219
  - Conduit to Conduit, Trapeze ... 235
  - Conduit to Stud ..... 251, 253
  - Conduit Support w/Bracket ... 250
  - Conduit to T-Bar ..... 256
  - Flange Mount Assembly ..... 240
  - Flexible (see Flexible Conduit)
  - Foam Pistons ..... 171
  - Hangers
    - Spring Steel ..... 234
    - Stainless Steel ..... 203
    - Steel ..... 202–203
  - Hubs ..... 56
  - Installation Clips, Quick
    - Spacers & Caps ..... 187
  - Measuring Tape ..... 170
  - Multi-Function
    - Clip Assembly ..... 237
  - Nail Straps, Flat & Round ..... 216
  - One-Hole Straps ..... 205–207
    - Stainless Steel ..... 206
  - Perforated Strapping ... 110, 231
  - Reducing Washers &
    - Bushings ..... 189
  - Roof Jacks, Flashing ..... 186
  - Service Entrance Caps ..... 186
  - Size Reference Charts ... 259–260
  - Sleepers, Pre-Kuts Plastic ..... 186
  - Strut Clamps, Universal ..... 218
  - Two-Hole Straps
    - Plastic ..... 210
    - Stainless Steel ..... 209
  - Z Purlin Assembly ..... 247–248
  - Cone Bits, 2-Flute Design** ..... 152
  - Contact Cleaner** ..... 114–116
  - Contractor I, SOG** ..... 161
  - Corrosion Compatibility** ..... 259
  - Corrosion Inhibitors** ..... 119
  - Crayons, Lumber** ..... 122
  - Crossfire Safety Glasses** ..... 176–177
  - Cut Point Staples** ... 269, 274–275
  - Cutting Oil** ..... 126
- D**
- Damaged Screw Removal Set** ..... 156
  - Deck Screws**
    - Woodex All-Weather, Square ... 45
  - Degreaser**
    - Contact ..... 116
    - Electronic ..... 117
    - General Purpose ..... 120
    - Selection Guide ..... 114–115
  - Deep Thread Particle Board** ..... 41–42
  - Dial-A-Bit Kit** ..... 140
  - Dial-A-Drill Set** ..... 147
  - Diamond Point Staples** ..... 270–273
  - Displays**
  - Accusharp® Knife Sharpener ... 282
  - Cully™ Screwdriver ..... 282
  - CrossFire® ..... 283
  - Glove ..... 283
  - Gondola Header & Display ... 281
  - Gravity Feed Jar
    - Header & Display ..... 280
  - Hex Power Bit ..... 282
  - Hole Saw, Morse® ..... 283
  - Jobber Drill ..... 283
  - Krylon®/Sprayon® ..... 282
  - Masonry Drill Bit ..... 283
  - Plastic Boxes ..... 282
  - Reciprocating Saw Blade,
    - Morse® ..... 283
  - Shovel Hooks ..... 283
  - SOG® ..... 282
  - Drill Bits**
  - Bell Hanger ..... 149
  - Carbide
    - Rotary/Percussion ..... 148
    - SDS Rotary/Hammer ..... 148
    - Straight Shank Rotary ..... 148
    - Tipped ..... 87
  - Dial-A-Drill Set ..... 147
  - Electrician’s Power Bits ..... 149
  - Flex Shank (Fish) ..... 149
  - Hex 135° Split Point Set ..... 147
  - Jobber High Speed
    - 118° Point ..... 144
    - 135° Point ..... 145
  - Sawtooth ..... 151
  - Special Set, Cobolt &
    - Titanium ..... 147
  - Speedbor 2000 ..... 151
  - Trinado
    - 135° Point Heavy Duty ..... 146
    - Metal Index Set
      - Heavy Duty ..... 146
  - Wood, Auger
    - 6" Ship ..... 150
    - 17" Ship ..... 150
    - Extension &
      - Sharpening File ..... 150
  - D-Rings** ..... 229
  - Driver Bit** ..... 140
    - Accessories ..... 140
    - Dial-A-Bit Kit ..... 140
    - Drill Adaptor ..... 140
    - Phillips
      - Hex Power ..... 141
      - Screwdriver ..... 134–135
    - Pozi Drive ..... 139
    - Slotted
      - Hex Power ..... 142
      - Screwdriver ..... 134–135
    - Socket Pin
      - Insert ..... 139, 143
      - Screwdriver ..... 135
    - Spanner
      - Insert ..... 139, 143
      - Screwdriver ..... 135
    - Square
      - Hex Power ..... 141
      - Screwdriver ..... 134–135
    - Star Pin
      - Insert ..... 139, 143
      - Screwdriver ..... 135
    - Tamperproof Insert ..... 143
    - Tri-Wing ..... 139, 143
  - Drive Stop® Diamond Point Staples** ..... 273
  - Drywall Anchors** ..... 78, 84–86, 89–100
  - Hole Saws ..... 153–154
  - Jab Saw ..... 156
  - Screws ..... 43–44
  - Duct Seal Compound** ..... 126
  - Duct Tape** ..... 174
  - Duplex Jiffy Clip** ..... 208
  - Dust Mask** ..... 180
- E**
- Ear Plugs** ..... 180
  - Electronic Cleaners** ..... 117
  - Degreasers** ..... 117
  - Entrenching Tool** ..... 165
  - Expander Anchors** ..... 100
  - Eye Bolts with Hex Nuts** ..... 75
  - Eye Lags** ..... 53–54
  - EZ Ancors™** ..... 91–93
  - EZ Toggle™ Ancors** ..... 89
- F**
- Far Side Box Support** ..... 253
  - Fender Washers** ..... 66
    - Stainless Steel ..... 66
  - Fiberglass Handled Tools** ..... 130–131
  - Fielder Mini, SOG®** ..... 163
  - Field Pup, SOG®** ..... 164
  - Fine Thread Drywall, Phillips** ..... 43
  - Finish Cup Washers**
    - Brass ..... 63
    - Stainless Steel ..... 63
  - Firestop Products**
  - Caulk ..... 129
  - Gaskets ..... 128
  - Lectra-Stop™ ..... 128
  - Pillows ..... 129
  - Putty Pad ..... 128
  - Putty Sticks ..... 129
  - First Aid Kits**
  - 10 Person ..... 182
  - 25 Person ..... 182
  - Fixture Hanging Hardware**
  - Brackets ..... 232
  - Chain ..... 109
  - Hangerbolts ..... 101
  - Lighting Support Assembly ... 223
  - Plumber’s Tape,
    - Perforated Strap ..... 110, 231
  - S-Hooks ..... 110
  - Stud Clip Adaptor ..... 231
  - T-Bar
    - Drop Wire Clip ..... 224
    - Hanger, Two-Piece ..... 224
    - Scissor Clip ..... 224
    - Twist-On ..... 254

Tie Wire ..... 108  
 Threaded Rod ..... 107  
 Bracket Supports ..... 241  
 Beam Assembly ..... 242  
 Flange Hanger ..... 249  
 Hangermate® ..... 106–107  
 Hangers ..... 258  
 Hex Rod &  
 Reduced Couplings ..... 108  
 Sammys® ..... 102–105  
 Z Purlin ..... 247  
 Troffer Fastener ..... 254  
 V-Hooks ..... 110

**Flange**  
 Cable/Conduit Clips ..... 236, 238  
 Clamps, Beam ..... 217, 244, 246  
 Clip, Two-Piece ..... 218  
 Hanger ..... 248–249  
 Multi-Function Clip ..... 237

**Flash I & II, SOG®** ..... 160  
**Flash Rescue, SOG®** ..... 161

**Flat Cut Washers**  
 Brass ..... 65  
 Silicon Bronze ..... 65  
 Stainless Steel ..... 64

**Flat Head Screws**  
 Machine  
 Brass ..... 52  
 Phillips ..... 36  
 Slotted ..... 35–36  
 Square ..... 34  
 Stainless Steel ..... 36  
 Wood, Square ..... 39–40  
 Sheet Metal  
 Square ..... 21  
 Spanner ..... 46  
 Stainless Steel ..... 22

**Flat Head Split Bolt Anchors** ... 79

**Flexible Conduit/Cable Clip**  
 Anti-Short Bushings ..... 172  
 Cable Clip ..... 236, 238  
 Cable Ties ..... 187–188  
 Connectors ..... 171  
 Hanger ..... 202, 234  
 Grommets ..... 172, 227  
 Knock-Out Bushings ..... 172  
 Nail Plates ..... 228  
 Straps  
 One-Hole ..... 205–207, 211  
 Two-Hole ..... 212  
 Stud Fastener ..... 250  
 Support  
 Bridle Rings ..... 226–227  
 D-Rings ..... 229

**Flex Shank Drill Bits (Fish Bits)**  
 Wood, Self-Feed  
 Screw Point ..... 149

**Foam Conduit Pistons** ..... 171

**Framing Screws** ..... 24

**Friction Tape** ..... 173  
**Fusion Micron, SOG®** ..... 161

**G**

**Galvanic Corrosion** ..... 259  
**Gaskets, Firestop** ..... 128  
**Glass Cleaner** ..... 120

**Gloves**  
 1927® Cold Weather  
 Grain Pigskin ..... 183  
 Fingerless Ragg Wool ..... 184  
 Frostbreaker® Thermal  
 Latex Gripping ..... 184  
 Grain Leather Drivers ..... 183  
 Kevlar® Lined ..... 184  
 Latex Coated Knit ..... 183  
 Lined Brown Jersey ..... 183  
 Nitrile Palm Coated ..... 184  
 Pro-Grip  
 Full Finger ..... 185  
 Half Finger ..... 185  
 Mechanic's Plus ..... 185  
 Mesh Utility ..... 185  
 Winter Plus ..... 185  
 PVC Dipped ..... 184  
 Split Leather Drivers ..... 183  
 Split Leather Work ..... 183  
 Unlined  
 Brown Jersey ..... 183  
 Deerskin Drivers ..... 183  
 Grain Pigskin Drivers ..... 183  
 Warm Grip Latex Work ..... 184  
 White  
 Canvas ..... 184  
 String Knit ..... 184

**Grade 2** ..... 71–72  
**Grade 5**  
 Bolts ..... 73  
 Nuts ..... 59

**Grommets, Steel Stud** ..... 172, 227  
**Green Plug Anchors** ..... 96

**Grounding**  
 Clamps ..... 56  
 Clips ..... 55, 215  
 Drive Stop® Staple ..... 273  
 Hubs ..... 56  
 Pigtails ..... 55  
 Screws ..... 55

**H**

**Hacksaw** ..... 157  
**Hangerbolts** ..... 101  
**Hangerbolt Drivers** ..... 101  
**Hangermate®**  
 Installation Tools ..... 107  
 Metal Applications ..... 106  
 Sidemount Applications ..... 107  
 Wood Applications ..... 106

**Hangers** ..... 202–203, 234  
 Beam Clamp ..... 217, 244, 246  
 Bridle Rings ..... 226–227  
 Chain, Jack & Tenso ..... 109  
 Conduit ..... 202–203, 234  
 Beam Assembly  
 Set Screw ..... 218, 245  
 Hammer On ..... 239–240  
 Z Purlin ..... 247–248  
 Eye Bolts ..... 75  
 Eye Lags ..... 53–54  
 Eye Tek's ..... 54  
 Flange ..... 247  
 Vertical ..... 248–249  
 J-Hooks ..... 225  
 Perforated Strap ..... 110, 231  
 Strap Hangers ..... 243  
 Threaded Rod ..... 107  
 Beam Assembly ..... 242  
 Bracket Assembly ..... 241  
 Hangermate® ..... 106–107  
 Sammys® ..... 102–105  
 Vertical Flange ..... 249  
 Z Purlin ..... 246–248

**Hard Hats** ..... 181  
 Blockhead ..... 181  
 Charger™ Safety Cap ..... 181  
 Liners ..... 181

**Hardware/Accessories** ..... 230–232  
**Hex Drill Set** ..... 147  
**Hex Driver Bits** ..... 142  
**Hex Head**  
 Bolts, Cap Screws ..... 71–73  
 Grade 2 ..... 71–72  
 Grade 5 ..... 73  
 Silicon Bronze ..... 51  
 Stainless Steel ..... 50  
 Lag Screws ..... 69

**Hex Nuts** ..... 57  
 Brass ..... 58  
 Flange Whiz ..... 59  
 Grade 5 ..... 59  
 Nylock ..... 60  
 Stainless Steel ..... 60  
 Silicon Bronze ..... 58  
 Stainless Steel ..... 59

**Hex Power Bits**  
 Phillips ..... 141  
 Slotted ..... 142  
 Square ..... 141

**Hex Rod Coupling** ..... 108  
**Hex Shank Taps** ..... 155  
**Hex Washer Head**  
 Sheet Metal Screw ..... 18–19  
 Sharp Points ..... 23  
 Tek Self-Drilling ..... 27–28

**High Speed Jobber Drills**  
 118° Point ..... 144  
 135° Point ..... 145

**Hole Saws**  
 Arbors & Pilot Drills ..... 152  
 Carbide Grit ..... 154  
 Kits ..... 153–154  
 Electrician's Hole Saw ..... 153  
 Maintenance ..... 154  
 Master Electrician's ..... 154  
 Variable Pitch, Bi-Metal ..... 153

**Hollow Wall Anchors** ..... 84–100  
 Combo Phillips/Slotted ..... 90  
 Drive Point ..... 90  
 Expander ..... 100  
 EZ Ancor® ..... 91–93  
 Green Plug ..... 96  
 Red Conical ..... 97–98  
 SnapSkru™ ..... 94  
 Toggle Bolt & Wings ..... 85–86  
 Toggler® Alligator® ..... 95  
 Toggler® Plastic ..... 91  
 Toggler® Snaptoggle® ..... 84  
 Wall Dog ..... 96  
 Yellow Winged ..... 99

**I**

**Insulated Metal Staples**  
 Plastic Insulator Cable ..... 264  
 PVC Dipped Cable ..... 264

**Insulated Plastic Staples**  
 Bell & Thermostat ..... 266  
 Non-Metallic  
 Sheathed Cable ..... 266  
 Plastic Cable ..... 265  
 Service Entrance ..... 266  
 Stacking Cable Staple ..... 265

**Inverted Marking Paint**  
 Krylon® Industrial Quik-Mark™ .. 111  
 Paint Accessories ..... 119  
 Paint Color Selection Guide... 112

**J**

**Jab Saw** ..... 156  
**Jack Chain** ..... 109  
 Stainless Steel ..... 109

**J-Hooks** ..... 225  
**Jiffy Clip®**  
 One-Hole Duplex ..... 208  
 One-Hole Strap  
 Heavy Duty ..... 207  
 K-Series ..... 204  
 Medium Series ..... 206  
 Min-E® Series ..... 206  
 Standard Series ..... 205  
 Slotted Duplex ..... 208

**Jobber Drill** ..... 144–145

**K**

**Kilowatt, SOG®** ..... 163

## Knife

- Sharpener, Accusharp® ..... 158
- SOG® ..... 159–165
- Fixed Knives
  - Entrenching Tool ..... 165
  - Field Pup ..... 164
  - Pentagon ..... 164
  - Pentagon Mini ..... 164
  - SEAL Pup ..... 165
  - SEAL Pup Elite ..... 165
  - SEAL Team ..... 164
  - SEAL Team Elite ..... 165
- Folding Knives
  - Blink ..... 162
  - Contractor I ..... 161
  - Field Mini ..... 163
  - Flash I ..... 160
  - Flash II ..... 160
  - Flash Rescue ..... 161
  - Fusion Micron ..... 161
  - Kilowatt ..... 163
  - Pentagon Elite ..... 161
  - Revolver ..... 163
  - Trident ..... 160
  - Twitch I ..... 162
  - Twitch II ..... 162
  - Twitch XL ..... 162
- Multi-Tools
  - Paratool ..... 159
    - Black Oxide ..... 159
  - Pocket Power Plier ..... 159
  - Powerlock ..... 159
    - with U-Cutter ..... 159
- Utility
  - Quickblade ..... 158
  - Titan, Folding ..... 158
- Knock-Out Bushings** ..... 172
- Krylon®** ..... 111–113, 121

## L

- Lag Screw** ..... 69
- Lag Screw Shields** ..... 82
- Lead Screw Anchors** ..... 82
- Lead Machine Screw Anchors** ..... 83
- Lectra-Stop™**,  
**Firestop Product** ..... 128
- Lighting**
  - Support Assembly ..... 223
  - Troffer Fastener, Acoustical ... 254
- Line Packages** ..... 170
- Lock Washers**
  - Octagonal ..... 62
  - Sealing ..... 62
  - Split ..... 68
    - Silicon Bronze ..... 67
    - Stainless Steel ..... 67

- Toothed Lock Washers
  - External ..... 62
  - Internal ..... 62

- Low Voltage Mounting Bracket** ..... 229
- Lubricants** ..... 117–118, 124
- Lumber Crayons** ..... 122

## M

### Machine Screws

- Flat Head
  - Brass ..... 52
  - Phillips ..... 36
  - Slotted ..... 35–36
  - Square ..... 34
  - Stainless Steel ..... 36
- Hex Head
  - Grade 2 ..... 72–73
  - Grade 5 ..... 73
  - Silicon Bronze ..... 51
  - Stainless Steel ..... 50
- Round Head
  - Phillips/Slotted Combo .. 29–30
  - Square/Slotted ..... 31–32
  - Stainless Steel ..... 33
- Socket Pin ..... 49
- Spanner ..... 48
- Star Pin ..... 49
- Truss Head
  - Phillips/Slotted ..... 37
  - Square/Slotted ..... 37
- Wall Plate ..... 38
- Malleable, Beam Clamps** ..... 217
- Marker Books** ..... 191–192

### Markers

- Dura-Ink® 15 Black ..... 122
- Lumber Crayon ..... 122

### MEGAPRO® Screwdrivers

- 15-in-1 ..... 134
- 16-in-1 ..... 135
- Quick Change ..... 135

### Metal Piercing Stud Screws

#### Metal Stud

- Box Mounting Bracket.... 220–221
- Box Stabilizer Support.... 222–223
- Box to Bar Fastener ..... 223
- Box to Stud Fastener ..... 251
- Box to Stud Support..... 252
- Bushings ..... 172, 227
- Conduit/Cable Support..... 250
- Conduit to Stud Fastener ..... 253
- Conduit to Stud Support ..... 251
- Far Side Box Support..... 253
- Flexible Conduit/Cable Fasteners ..... 250
- Mule Tape** ..... 169

- Multi-Function Clip** ..... 237
  - Assemblies ..... 237
- Multi-Purpose Closed Clip** ..... 210
- Mushroom Head Toggle Bolts** ..... 85

## N

### Nail Plates (Safety Plates) ..... 228

#### Nails

- Common Nails Size Guide ..... 276
- Copperclad Common ..... 277
- Galvanized Common ..... 276
- Galvanized Marking ..... 277
- Galvanized Roofing ..... 276

#### Nail Straps

- Combo EMT/Rigid ..... 216
- Round Nail Straps ..... 216

#### Non-Insulated Metal Staples

- Cable ..... 263
- Service Entrance ..... 263

#### Non-Metallic Sheathed Cable Connectors

- ..... 171

#### Non-Metallic Sheathed Cable Staples

- ..... 266

#### Nut Driver ..... 138, 142

#### Nuts ..... 58–60

- Cap ..... 61
- Flange Whiz ..... 59
- Hex ..... 57
  - Brass ..... 58
  - Grade 5 ..... 59
  - Nylock ..... 60
  - Stainless Steel ..... 60
  - Silicon Bronze ..... 58
  - Stainless Steel ..... 59
- Wing ..... 61, 230

## O

### Octagonal, Washers ..... 62

### One-Hole Duplex ..... 208

### One-Hole Strap ..... 204–207, 211

- Heavy Duty Series ..... 207
- K-Series ..... 204
- Medium Series ..... 206
- Min-E® Series ..... 206
- Service Entrance ..... 211
- Standard Series ..... 205

### Outlet Retainer ..... 221

## P

### Paint & Chemicals ..... 111–129

- All Purpose Rags ..... 127
- Chemicals
  - Adhesive ..... 125
  - Industrial E-6000® ..... 125
  - Repositionable ..... 121

- Cleaners
  - Contact ..... 116
  - Electronic ..... 117
  - General Purpose ..... 120
  - Glass ..... 120
  - Selection Guide ..... 114–115
  - Cutting Oil, Dark ..... 126
  - Corrosion Inhibitors ..... 119
- Degreaser
  - Contact ..... 116
  - Electronic ..... 117
  - General Purpose ..... 120
  - Selection Guide ..... 114–115
- Firestop Products
  - Caulk ..... 129
  - Caulking Gun ..... 129
  - Gaskets ..... 128
  - Lectra-Stop™ ..... 128
  - Pillow ..... 129
  - Putty Pads ..... 128
  - Putty Sticks ..... 129
- Insect Repellents ..... 121
- Insulating Varnishes ..... 119
- Lubricants
  - Sprayon® ..... 118
  - Tri-Flow® ..... 124
- Sealants
  - Duct Seal ..... 126
  - Roof Cement ..... 125
  - Silicone Caulk ..... 124
  - Sparyon® Silicone ..... 124
  - Stop Gap!™ ..... 125
- Lumber Crayons ..... 122
- Markers ..... 122
- Paint
  - Accessories ..... 112
  - Acrylic Enamel ..... 113
  - Color Selection Guide ..... 112
  - Inverted Marking ..... 111
  - Scrubs-In-A-Bucket ..... 127
  - Technical Glossary ..... 123
- Pan Head Framing Screws**
  - Sharp Point ..... 24
  - Tek ..... 24
- Machine Screw, Spanner ..... 48
- Sheet Metal Screw
  - Phillip/Slotted Combo ..... 17
  - Phillips, Stainless ..... 18
  - Spanner ..... 46
  - Square ..... 14–15
  - Stainless Steel ..... 16
- Tek Sheet Metal Screws
  - Phillips ..... 26
  - Square ..... 25
  - Wall Dog ..... 96
- Paratool, SOG®** ..... 159
- Particle Board Screws** ..... 41–42
- Pentagon, SOG®** ..... 164
- Pentagon Elite, SOG®** ..... 161

**Pentagon Mini, SOG®** ..... 164

**Perforated Strapping** ..... 110, 231

**Phillips Hex Power Bits**..... 141

**Phillips Screw**

  Drywall

    Coarse ..... 44

    Fine ..... 43

  Machine

    Flat Head ..... 36

    Round Head Stainless ..... 33

  Sharp Point

    Framing ..... 24

    Wafer Head ..... 23

  Sheet Metal, Stainless ..... 18

  Tek, Self-Drilling

    Framing ..... 24

    Pan Head ..... 26

    Wafer Head, Lath ..... 28

**Phillips Screwdriver** ..... 138

  Insulated ..... 138

**Phillips/Slotted Screws**

  Machine

    Round Head ..... 29–30

    Truss Head ..... 37

  Mushroom Head Toggle Bolt... 85

  Sheet Metal

    Hex Washer Head ..... 18

    Pan Head ..... 17

    Stove Bolts w/ Nuts ..... 74

**Pick Mattock** ..... 130–131

**Pillow, Firestop** ..... 129

**Pipe Sleepers** ..... 186

**Pipe Spacers** ..... 187

**Pipe Wrap**..... 174

**Plastic Cable Staples**..... 265

**Plumber's Tape**

**(Perforated Strap)** ..... 110, 231

**Polyester Tape**

  Conduit Measuring ..... 170

  Pulling ..... 169

**Polypropylene**

  Blow Twine ..... 170

  Yellow Pull Rope ..... 169

**Post Hole Digger** ..... 130–131

**Pouches & Bags**..... 132

**Powerlock, SOG®**..... 159

**Power Pocket Plier, SOG®** ..... 159

**Pre-Kuts Plastic Sleepers**..... 186

**Purlin Hangers** ..... 246–248

**Putty, Firestop**

  Pad ..... 128

  Sticks ..... 129

**PVC Electrical Tape**..... 173

## Q

**Quickblade™, Utility Knife**..... 158

**Quick-Caps** ..... 187

**Quick Change**..... 140

  Drill Adapter ..... 140

  Screwdrivers, MEGAPRO® ..... 135

**Quick Spacers**..... 187

**Quickie Tie-Down** ..... 168

## R

**Rakes** ..... 130–131

**Receptacle Shim** ..... 171

**Reciprocating Saw Blades** ..... 157

**Red Plastic**

**Conical Anchors**..... 97–98

**Reducing Bushings**..... 189

**Reducing Washers**..... 189

**Repositionable Adhesive**..... 121

**Repellents, Insect** ..... 121

**Revolver, SOG®**..... 163

**Rod Clips** ..... 236–237

**Rod Hangers** ..... 258

**Rod to Flange Hanger** ..... 249

**Rod/Wire, Hangers**

  Beam Assemblies ..... 242

  Bracket Support ..... 241

**Roof Cement** ..... 125

**Roof Jacks (Flashings)**..... 186

**Rotary Carbide Drill Bits**..... 148

**Round**

  Head Machine Screw

    Brass ..... 52

    Phillips/Slotted ..... 29–30

    Square/Slotted ..... 31–32

    Stainless Steel ..... 33

    w/ Hex Nuts ..... 74, 230

  Head Toggle Bolts, Slotted ..... 86

  Nail Straps, Combo

    EMT/Rigid ..... 216

  Washer Head, Sheet Metal

    Screw, Square ..... 20

**Rubber Tape** ..... 173

## S

**Safety**

  Barricade & Caution Tape ..... 175

  Dust Masks ..... 180

  First Aid Kits ..... 182

  Glasses

    Crossfire® ..... 176–177

    Cobra ..... 177

    Core ..... 177

    ES4 ..... 176

    ES5 ..... 176

    Infinity ..... 176

    KP6 ..... 177

    RPG ..... 177

    Sniper ..... 176

    Hellraiser™ ..... 179

  Nemesis™ ..... 178

  RX™ ..... 178

  VI™ ..... 178

  OTG (Over the Glasses)..... 179

  Smith & Wesson® ..... 179

  Gloves ..... 183–185

  Hard Hats ..... 181

  Hearing Protection ..... 180

  Vests ..... 180

**Sammy's® Anchoring System**

  for Concrete

    Horizontal Mounting ..... 104

    Vertical Mounting ..... 104

  for Steel

    Horizontal Mounting ..... 103

    Vertical Mounting ..... 103

  for Wood

    Horizontal Mounting ..... 102

    Vertical Mounting ..... 102

  Sammy® X-Press ..... 105

**Saw**

  Hacksaw ..... 157

  Hole Saw ..... 153–154

  Jab Saw ..... 156

  PVC Cable Saw ..... 157

  Reciprocating Saw Blades ..... 157

**Sawtooth Self-Feeding Bits**... 151

**Screwdrivers**..... 134–138

  6-in-1 Economy ..... 136

  13-in-1 Ratcheting ..... 136

  14-in-1 HVAC ..... 136

  15-in-1 ..... 134

  15-in-1 Shaftlock ..... 137

  15-in-1 Tamperproof 2 ..... 136

  16-in-1 Tamperproof ..... 135

  Cabinet ..... 138

  Nut Driver ..... 138

  Phillips ..... 138

  Insulated ..... 138

  Slotted ..... 138

  Spanner ..... 137–138

  Square Drive ..... 137

  Un-Do-It ..... 137

**Screws**

  Acoustical Eye

    Lags & Tekes ..... 54

  Deck, Woodex® ..... 45

  Drywall ..... 43–44

  Cap Screws, Hex Head ..... 71–73

    Silicon Bronze ..... 51

    Stainless Steel ..... 50

  Extractions

    Damaged Screw

      Removal Set ..... 156

    Screw Extractor & Drill Bit.. 156

  Eyes Lags ..... 53–54

  Framing Sharp & Tek ..... 24

  Grounding ..... 55

  Hooks ..... 53

  Machine

    Brass ..... 52

    Flat Head ..... 34–36

      Stainless Steel ..... 36

    Round Head ..... 29–32

      Stainless Steel ..... 33

    Truss Head ..... 37

    Socket Pin ..... 49

    Spanner ..... 48

    Star Pin ..... 49

  Lag, Hex ..... 69

  Particle Board ..... 41–42

  Sharp Points

    Hex Head ..... 23

    Wafer Head ..... 23

  Sheet Metal

    Flat Head, Square ..... 21

    Stainless Steel ..... 22

  Hex Washer Head

    Phillips/Slotted Combo .... 18

    Slotted ..... 19

  Oval, Square Stainless ..... 22

  Pan Head ..... 14–18

    Phillips/Slotted Combo .... 17

    Phillips, Stainless ..... 18

    Square Drive ..... 14–15

      Stainless ..... 16

  Round Washer Head, Square.. 20

  Socket Pin ..... 47

  Spanner Head ..... 46

  Star Pin ..... 47

  Tamperproof ..... 46–49

  Tek Self-Drilling

    Hex Washer Head ..... 27–28

    Stainless Steel ..... 28

  Pan Head ..... 25–26

  Wafer Head Lath ..... 28

  Wall Plate ..... 38

  Wood

    Flat Head ..... 39–40

    Trim Head ..... 41

**Scrubs-In-A-Bucket®** ..... 127

**SDS Rotary/Hammer**

**Carbide Drill Bits**..... 148

**Sealants**

  Duct Seal ..... 126

  E-6000® Industrial Adhesive.. 125

  Sprayon® Clear Silicon ..... 124

  Wet Patch Roof Cement ..... 125

  White Lightening® Silicon ..... 124

  White Lighting® Stop Gap!™.. 125

**Sealing Washers** ..... 62

**SEAL Pup, SOG®** ..... 165

**SEAL Pup Elite, SOG®** ..... 165

**SEAL Team, SOG®** ..... 164

**SEAL Team Elite, SOG®** ..... 165

**Service Entrance**

  Caps ..... 186

  Staples ..... 263, 266



Straps			
One-Hole.....	211		
Two-Hole.....	212		
<b>Setting Tool</b> .....	83		
<b>Steel Drop-In Anchors</b> .....	83		
<b>Sharpener, Knife</b> .....	158		
<b>Sheet Metal Screws</b>			
Flat Head, Square.....	21		
Stainless Steel.....	22		
Hex Washer Head			
Phillips/Slotted Combo.....	18		
Slotted.....	19		
Oval, Square Stainless.....	22		
Pan Head.....	14–18		
Phillips/Slotted Combo.....	17		
Phillips, Stainless.....	18		
Square.....	14–15		
Round Washer Head, Square.....	20		
<b>S-Hooks</b> .....	110		
<b>Shim Receptacle</b> .....	171		
<b>Shovels, Fiberglass</b>			
Handled.....	130–131		
<b>Sledge Hammers, Fiberglass Handled</b> .....	130–131		
<b>Sleeve Anchors, Concrete/Masonry</b> .....	76		
<b>Slotted</b>			
Duplex Jiffy Clip®.....	208		
Hex Power Bits.....	142		
Screwdriver & Insulated.....	138		
Screws, Machine			
Brass.....	52		
Flat Head.....	52		
Round Head.....	52		
Flat Head.....	35–36		
Stainless Steel.....	36		
Round Head, Stainless.....	33		
Toggle w/ Wing.....	86		
Wall Plate.....	38		
<b>Small-Head Shovel</b> .....	130–131		
<b>Snap-In Knock Out-Seals</b> .....	190		
<b>Socket Pin</b>			
Insert Bits.....	143		
Machine Screws.....	49		
Sheet Metal Screws.....	47		
<b>SOG®</b>			
Fixed Knives			
Entrenching Tool.....	165		
Field Pup.....	164		
Pentagon.....	164		
Pentagon Mini.....	164		
SEAL Pup.....	165		
SEAL Pup Elite.....	165		
SEAL Team.....	164		
SEAL Team Elite.....	165		
Folding Knives			
Blink.....	162		
Contractor I.....	161		
Fielder Mini.....	163		
Flash I.....	160		
Flash II.....	160		
Flash Rescue.....	161		
Fusion Micron.....	161		
Kilowatt.....	163		
Pentagon Elite.....	161		
Revolver.....	163		
Trident.....	160		
Twitch I.....	162		
Twitch II.....	162		
Twitch XL.....	162		
Multi-Tools			
Paratool.....	159		
Pocket Power Plier.....	159		
Powerlock.....	159		
with V-Cutter.....	159		
<b>Spacer, Wiring Device</b> .....	171		
<b>Spanner</b>			
Drive & Un-Do It Tool.....	137		
Machine Screws.....	48		
Insert Bits.....	143		
Sheet Metal Screws.....	46		
<b>“Spark Plugs” Hearing Protection</b> .....	180		
<b>Speedbor 2000™ Wood Bits</b> .....	151		
<b>Split Lock Washers</b> .....	68		
Silicon Bronze.....	67		
Stainless Steel.....	67		
<b>Sprayon®</b>			
Blast ‘Em Wasp & Hornet.....	121		
Contact Cleaner			
Selection Guide.....	114–115		
Clear Silicone.....	124		
Cutting Oil.....	118		
Electric Motor Degreaser.....	117		
Electrical Cleaner & Lubricating.....	117		
Electrical Degreaser, Non-Chlorinated.....	117		
Electronic Contact Cleaner.....	116		
Environmental			
Contact Cleaner.....	116		
and Degreaser.....	117		
Flash Free Safety Solvent & Degreaser.....	116–117		
General Purpose Cleaner.....	120		
Heavy Duty Foaming Degreaser, Neutra-Force®.....	120		
Heavy Duty Glass Cleaner.....	120		
Heavy Duty Open			
Gear/Wire Rope Lube.....	118		
Insect Repellents.....	121		
Insulating Varnish.....	119		
Long Term Indoor			
Protectant & Lube.....	119		
Lubricant, 711® Protector™.....	118		
Plastics Contact Cleaner.....	116		
Rust Breaker™, Penetrant.....	118		
Silicone Lube, Premium.....	118		
Zinc Rich Cold			
Galvanizing Compound.....	119		
<b>Spring Steel Washers, Belleville</b> .....	63		
<b>Square Drive</b>			
Deck Screws, Woodex®			
All-Weather.....	45		
Hex Power Bits.....	141		
Machine Screw, Flat Head.....	34		
Screwdrivers.....	138		
Sheet Metal Screw			
Flat Head.....	21		
Stainless Steel.....	22		
Oval Head, Stainless.....	22		
Pan Head.....	14–15		
Stainless Steel.....	16		
Round Washer Head.....	20		
Tek Self-Drilling Screw.....	25		
Wood Screw			
Deep Thread,			
Particle Board.....	41–42		
Flat Head.....	39–40		
Trim Head.....	41		
<b>Square/Slotted Machine Screws</b>			
Round Head.....	31–32		
Truss Head.....	37		
<b>Staples</b>			
Residential			
Insulated.....	264–266		
Bell & Thermostat.....	266		
Non-Metallic Sheathed			
Cable.....	266		
PVC Dipped Cable.....	264		
Plastic Insulator Cable.....	264		
Plastic Cable.....	265		
Service Entrance			
SER.....	266		
SEU.....	266		
Stacking Cable.....	265		
Non-Insulated			
Cable.....	263		
Service Entrance.....	263		
Utility			
Cut Point.....	269, 274–275		
Copperclad.....	275		
Galvanized.....	275		
Pre-Galvanized.....	274		
Square Wire Barbed.....	269		
Diamond Point.....	270–273		
Bright Wire.....	270–271		
Copperclad.....	272		
Drive Stop®.....	273		
Electo-Zinc.....	271		
Flat Top.....	273		
Serrated.....	273		
Galvanized.....	272		
Double Barbed.....	272		
Serrated.....	273		
<b>Star Pin</b>			
Insert Bits.....	143		
Machine Screws.....	49		
Sheet Metal Screws.....	47		
<b>Steel Drop-In Anchors</b> .....	83		
<b>Steel Stud</b>			
Box Mounting Bracket.....	220–221		
Box Stabilizer Support.....	222–223		
Box to Bar Fastener.....	220		
Box to Stud Fastener.....	251		
Box to Stud Support.....	252		
Bushings.....	172, 227		
Conduit/Cable Support.....	250		
Conduit to Stud Fastener.....	253		
Conduit to Stud Support.....	251		
Far Side Box Support.....	253		
Flexible Conduit/Cable			
Fasteners.....	250		
<b>Step Drills, 2-Flute Split Tip</b> .....	152		
<b>Stove Bolts</b>			
Slotted/Phillips			
with Hex Nuts.....	74, 230		
Stainless Steel w/ Nut.....	230		
<b>Straight Shank</b>			
Carbide Drill Bits.....	148		
<b>Strap Hangers</b> .....	243		
<b>Strapping Tape</b> .....	174		
<b>Strike Set Anchors, Concrete</b> .....	77		
<b>Strut Clamps</b> .....	215		
<b>Stud Clip Adapter</b> .....	231		
<b>Suspenders</b> .....	132		
<b>T</b>			
<b>Tamperproof</b>			
15-in-1 Screwdriver.....	136		
29-in-1 Driver Kit.....	139		
Driver Bits.....	139		
Insert Bits.....	143		
Machine Screws.....	48–49		
Sheet Metal Screws.....	46–47		
<b>Tape</b>			
Barricade & Caution			
Caution-Caution-Caution.....	175		
Caution High Voltage.....	175		
Gas Line Below.....	175		
Black PVC Electrical.....	173		
Carton Sealing.....	174		
Color-Coded PVC Electrical.....	173		
Conduit Measuring.....	170		
Duct.....	174		
Friction.....	173		
Mule/Pulling.....	169		
Plumbers Perforated			
Strap.....	110, 231		
Pipe Wrap.....	174		
Rubber.....	173		
Strapping.....	174		
Underground			
Burial.....	175		
Detectable.....	175		
<b>Tape Measure</b> .....	168		

## T-Bar

- Box Hanger Assembly.....223
- Drop Wire Clip .....224
- Fasteners .....254–256
- Flange Clip .....218
- Hanger, Two-Piece.....224
- Lightening Support Assembly.....223
- Scissor Clip .....224
- Twist on Hanger .....254

## Tek Self-Drilling Screws

- Framing.....24
  - Hex Washer Head .....27–28
  - Pan Head Tek .....25–26
  - Stainless Steel.....28
- ## Threaded Rod
- Bracket Support .....241
  - Coupling.....108
  - Hangers .....258
  - to Beam Assembly.....242
  - to Vertical Flange Assembly ....249
  - to Z Purlin Assembly .....247

## Tie Wire

## Toggle Bolts

- EZ Toggle™ Ancors.....89
- Mushroom Head.....85
- Round Head.....86
- Wings.....86

## Toggler®

- Alligator® Wall Anchors.....95
- Plastic Toggle .....91
- SnapSkru™ Anchor .....94
- Snaptoggle® Toggle Bolt.....84

## Tool Bags & Accessories

- .....132–133

## Tool Kits

- Carbon Steel Taps.....155
- Hex Shank Taps.....155
- Hole Saws
  - Electrician's Hole Saw Kit....153
  - Maintenance Kit .....154
  - Master Electrician's Kit.....154
- Screw Extractors .....156
- Tamperproof.....139
- Tapcon™ Condrive Installation..87
- Uraseal Splice Kits.....167

## Tools

- Anchor Setting.....83
- All Purpose Bar
  - w/Tamper.....130–131
- Bags & Accessories.....132–133
- Blow Twine.....170
- Cable Management .....171–172
- Caulk Gun .....124
- Condrive Installation.....87
- Conduit Measuring Tape .....170
- Drill Bits .....87, 144–152
- Driver Bits .....139–143
- Dust Masks .....180
- Ear Plugs.....180

- Firestop Caulking Gun.....129
- Foam Conduit Pistons.....171
- Gloves.....183–185
- Hangerbolt Driver .....101
- Hangermate Installation.....107
- Hard Hats .....181
- Hole Saws.....152–154
- Knives & Accessories....158–165
- Line Packages.....170
- Marking Wand.....112
- Picking Mattock.....130–131
- Post Hole Digger.....130–131
- Pull Rope.....169
- Pulling Tape.....169
- Rakes.....130–131
- Safety Glasses.....176–179
- Safety Vest .....180
- Sammys® Nut Driver ....102–104
- Sammys® Universal X-Press..105
- Saws.....156–157
- Screwdrivers .....134–138
- Shovels .....130–131
- Sledge Hammer.....130–131
- Splice Kits .....167
- Tape .....173–175
- Tape Measure.....168
- Tie Down Straps.....168
- Utility Probe.....130–131

## Toothed Lock Washers

- External.....62
- Internal.....62

## Trident, SOG®

## Tri-Flow Lubricants

- with PTFE .....124

## Trim Head Wood Screws

## Trinado Heavy-Duty Drills

## Trubolt® Wedge Anchors

## Truss Head Machine Screws

- Phillips/Slotted .....37
- Square/Slotted .....37

## Twist on T-Bar Hanger

## Twitch I, SOG®

## Twitch II, SOG®

## Twitch XL, SOG®

## Two-Hole Metal Conduit Strap

- Heavy-Duty .....210
- Metal.....209
- Plastic .....210
- Service Entrance .....212

## U

## U-Bolts

## Underground

- Burial Tape .....175
- Detectable Tape.....175
- Grounding Clamps.....56
- Splice Kits .....167

## Universal Clamps

- Beam .....217
- Pipe.....215

## Uraseal Splice Kits

## Utility Knives

## Utility Probe

- Fiberglass Handled.....130–131

## V

## Variable Pitch Hole Saws

## V-Hooks

## Voice/Data & Low Voltage

- Cable Protection
  - Nail Plates.....228
- Cable Support
  - Bridle Rings .....226–227
  - D-Rings.....229
  - J-Hooks.....225
- Low Voltage
  - Mounting Bracket.....229
- Metal Stud Grommet .... 172, 227
- Wing Nut Washer.....230

## W

## Wafer Head Screws

- Tek, Lath .....28
- Sharp Point.....23

## Wall Plate

- Insulating Gasket.....189
- Mounting Bracket.....229
- Screws.....38

## Washers

- Belleville
  - Spring Steel .....63
  - Stainless Steel .....63
- Fender.....66
- Stainless Steel .....66
- Finish Cup
  - Brass .....63
  - Stainless Steel .....63
- Flat Cut .....64
- Brass .....65
- Silicon Bronze .....65
- Stainless Steel .....64
- Octagonal.....62
- Sealing.....62
- Split Lock Washers .....68
- Silicon Bronze .....67
- Stainless Steel .....67
- Toothed Lock Washers.....62

## Wedge Anchors, Trubolt®

- Stainless Steel.....80

## Wet Patch Roof Cement

## White Lighting®

- Silicone Sealant .....124

## White Lightning® Stop Gap!™

## Wiring Device Spacer

## Wing Nut

## Wing Nut Washer

## Wire & Cable

## Marker Books

## Wood Drill Bits

- Auger
  - 6" Ship .....150
  - 17" Ship .....150
  - Bit Extensions .....150
  - Sharpening File .....150
- Bell Hanger .....149
- Self-Feed Screw Point
  - Electrician's Power.....149
  - Flex Shank Drill (Fish Bits)....149
- Sawtooth Self-Feeding .....151
- Sharpening File .....150
- Speedbor 2000™ Wood.....151

## Woodex® Deck Screws,

## Square

## Wood Hole Saws

## Wood Screws

- Deep Thread
  - Particle Board.....41–42
- Flat Head.....39–40
- Trim Head.....41

## Y

## Yellow Polypropylene Rope

## Yellow Winged Anchors

## Z

## Zamac Nail-In Anchors

## Z Purlin

- Flange Hanger.....248
- Hanger .....246
- Assemblies .....247–248



## Simple. Brilliant.

The new and improved Cully™ labels provide clear descriptions in an easy to read format while featuring vibrant colors. The labels have been transformed to make identifying fasteners on the rack or on the job site faster than before. It's also easier and more convenient to keep organized through small count quantities and stacking jar capabilities.

# Solutions

Powered by Relationships.

Resolving issues that challenge you the most is the core of the way we do business. It is our job to understand your changing environment as well as the demands before you. Providing the right solution for the requirement is what sets us apart from those that focus on selling your products.

We strive to build a strong relationship by fulfilling your needs and delivering the right solution.

Distributed By:

**Minerallac**<sup>®</sup>  
Company

[www.minerallac.com](http://www.minerallac.com)

COM00002